

NRW[®]
DRIVE TECHNOLOGIES

D/M SERIE

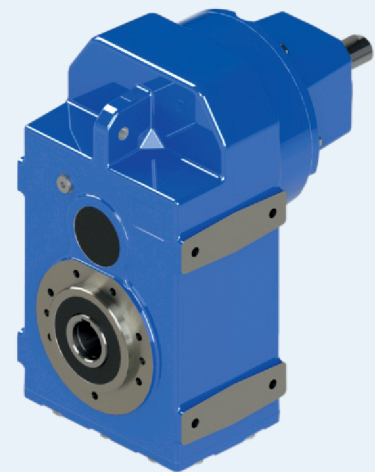

Flachgetriebemotoren
Shaft Mounted Geared Motors
Motoriduttore Pendolare
Motoréducteur Pendulaire
Motorreductor Pendular

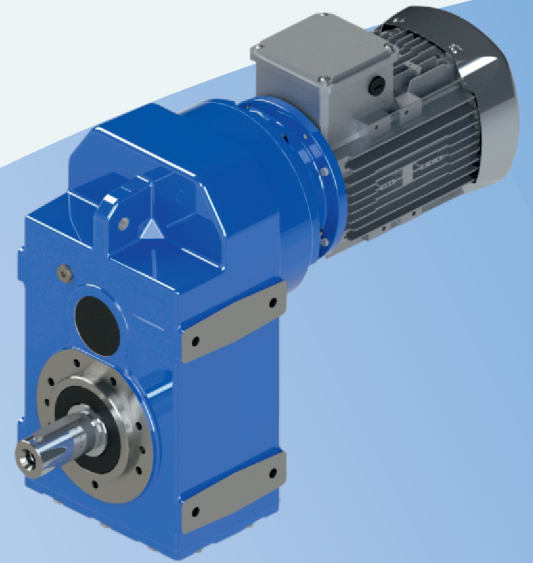

Eine Änderung in diesem Katalog der Technischen Werte sowie Daten und Maßen und Gewichte bleiben vorbehalten

We reserve the right to without previous notice for changing or fully change-over or cancelling which information is specified at catalogue

NRW[®]
DRIVE TECHNOLOGIES

INHALT / CONTENTS / INDICE / INDEX / INDICE

Zeichen / Symbols / Simbologia / Symboles / Simbologia	3
Technische Informationen / Technical Information / Informazioni Tecniche / Informacion Tecnica / Información Técnico.....	4 - 7
Betriebsfaktor / Service factor / Fattore di servizio / Facteur de service / Factor de servicio.....	8 - 9
Kristische anwendungen / Critical applications / Applicazioni critiche / Applications critiques / Aplicaciones Criticas.....	10 - 11
Thermische Leistung / Thermal Power / Potenza termica / Puissance thermique / Potencia térmica.....	12 - 15
Montage des motors an den PAM - Flansch B5 / Motor mounting with PAM flange B5 / Montaggio motore su flange B5 / Installation moteur sur bride PAM B5 / Montaje de motores con brida B5.....	16
Elastische Kupplung / Flexible joint / Giunto Elastico / Accouple. Élastique / Acopl. Elástico.....	17
Montage / Installation / Installazione / Installation / Instalación.....	18 - 19
Querbelastrungen / Radial loads / Carichi radiali / Charges radiales / Cargas radiales	20 - 22
Massenträgheitsmomente / Moments of inertia / Momenti d'inertzia / moments d'inertie / Momentos de inercia.....	23
Schmierung / Lubrication / Lubrificazione / Lubrification / Lubricación	24 - 26
Einbaulage / Mounting positions / Piazzamento / Pos. de montage / Pos. de montaje.....	27 - 29
Modulares Baukastensystem / Modularity / Modularità / Modularité / Modularidad.....	30
Produkte / Products / Prodotti / Produits / Productos	31-32
Beispiel Bestellbeschreibung / Example for ordering / Esempio di ordinazione / Exemple de commande / Ejemplo orden de compra	33
Bezeichnung / Designation / Designazione / Désignation / Designación.....	34
Nomenklatur / Nomenclature / I termini usati / Les termes utilisés / Los términos utilizados.....	35
Zubehör / Accessories / Accessori / Accessoires / Accesorios.....	36- 41
Auswahltablelle von Getriebemotoren / Selection Tables of Gearedmotors / Tabella di selezione di motoriduttori / Tableau de sélection du motoreducteurs / Tabla de selección de motorreductores.....	43 - 76
Maßtabellen / Dimension Tables / Dimensione Tabelle / Tables de Dimension / Tablas de Dimensiones.....	77 - 87
Auswahltablelle von W - PAM - IEC Adapters / Selection Tables of W - IEC and PAM Adapters / Tabella di selezione di W - PAM - IEC Adattatore / Tableau de sélection du W - PAM - IEC Adaptateur / Tabla de selección de W - PAM - IEC Adaptador.....	89 - 95
Allgemeine Stuckliste / General Part List / Generale Elenco Delle Parti / Générale la liste des pièces / Lista de Piezas en General....	96 - 113
Elektromotoren / Electric Motors / Motori elettrici / Moteurs électriques / Motores eléctricos.....	114 - 134
Motor Teil liste / Motor Parts List / Parti motore list / Pièces de moteur liste / Piezas del motor lista.....	135 - 138
Bremse teil liste / Brake parts list / Elenco delle parti freno / Liste des pièces de frein / Lista de piezas de freno.....	139



A series of horizontal dotted lines spanning the width of the page, intended for writing or drawing.

DE ZEICHEN

EN SYMBOLS

IT SIMBOLOGIA

FR SYMBOLES

ES SIMBOLOGIA

Zeichen

P = Leistung in	(kW)	1 = Antriebswelle
M = Drehmoment in	(Nm)	2 = Abtriebswelle
n = Drehzahl in	(rpm)	R = Radial
i = Übersetzung		A = Axial
F = Kraft in	(N)	s = Statisch
m = Masse in	(kg)	d = Dynamisch
f_B = Betriebsfaktor		max = Maximal
		min = Minimal

Symbols

P = Power	(kW)	1 = Input shaft
M = Torque	(Nm)	2 = Output shaft
n = Speed	(rpm)	R = Radial
i = Reduction ratio		A = Axial
F = Load	(N)	s = Static
m = Weight	(kg)	d = Dynamic
f_B = Service factor		max = Maximum
		min = Minimum

Simbologia

P = Potenza	(kW)	1 = Albero ingresso
M = Momento torcente	(Nm)	2 = Albero uscita
n = Numero giri	(giri / 1')	R = Radiale
i = Rapporto di riduzione		A = Assiale
F = Forza	(N)	s = Statico
m = Peso	(kg)	d = Dinamico
f_B = Fattore di servizio		max = Massimo
		min = Minimo

Symboles

P = Puissance	(kW)	1 = Arbre d'entrée
M = Moment de torsion	(Nm)	2 = Arbre de sortie
n = Nombre de tours	(tours/min)	R = Radial
i = Rapport de réduction		A = Axial
F = Force	(N)	s = Statique
m = Poids	(kg)	d = Dynamique
f_B = Facteur de service		max = Maximum
		min = Minimum

Simbologia

P = Potencia	(kW)	1 = Eje de entrada
M = Momento torsor	(Nm)	2 = Eje de salida
n = Número de revoluciones	(rpm)	R = Radial
i = Relación de reducción		A = Axial
F = Fuerza	(N)	s = Estático
m = Peso	(kg)	d = Dinámico
f_B = Factor de servicio		max = Máximo
		min = Mínimo

DE TECHNISCHE INFORMATIONEN

Für die korrekte Auswahl eines Getriebes oder eines Getriebemotors müssen einige grundsätzliche Daten bekannt sein, wie:

A- Die Antriebsdrehzahl am Getriebeeingang (n_1) und die gewünschte Abtriebsdrehzahl (n_2). Mit diesen beiden Werten kann das Übersetzungs-Verhältnis (i) des Getriebes mit der folgenden Formel ausgerechnet werden:

$$i = \frac{n_1}{n_2}$$

B- Das für die Anwendung erforderliche Drehmoment (MH). Wenn diese Daten bekannt sind, kann mit der Auswahl des Getriebemotors oder des Getriebes fortgefahren werden.

Auswahl der Getriebemotoren

Dieser Ratgeber führt in wenigen Schritten durch die Auswahl des geeigneten Antriebes:

1. Den Betriebsfaktor der Anwendung bestimmen (f_b). Dieser Parameter ist eine Funktion aus der Belastungsart der angetriebenen Maschine, der Anzahl der Anläufe pro Stunde und der Betriebs-stundenzahl (siehe Absatz "Betriebsfaktor" S.8)
2. Die Eingangsleistung PH über das erforderliche Drehmoment MH, die Geschwindigkeit n_2 und den dynamischen Wirkungsgrad ermitteln. Der Wert des dynamischen Wirkungsgrads hängt von der Art des Getriebes und von der Anzahl der Übersetzungsstufen ab. Für die Kegelstirnradgetriebe der Serie D/M gilt ein mittlerer Wert von (η_d):
D/M... 2 Übersetzungsstufen = 0,96
3 Übersetzungsstufen = 0,94

$$PH = \frac{MH \cdot n_2}{9550 \cdot \eta_d}$$

3. Eine genormte Leistung P1 aus der Tabelle der Getriebemotorenleistungen aussuchen, die höher ist als die erforderliche PH, sodass:

$$P_1 \geq PH$$

4. Nach dem Ermitteln der geeigneten genormten Leistung den Getriebemotor auswählen, die der Abtriebsdrehzahl zur Verfügung stellt, die der gewünschten n_2 am nächsten kommt, und der einen gleich hohen oder größeren Betriebsfaktor f_b besitzt als durch die Anwendung gefordert.

In den Auswahltabellen der Getriebemotoren sind die Kombinationen mit 50Hz - Motoren mit 2, 4 oder 6 Polen dargestellt. Für abweichende Antriebsgeschwindigkeiten berücksichtigen Sie bitte die Daten aus den Getriebetabellen.

EN TECHNICAL INFORMATION

For correctly selecting a gear reducer or geared motor, several essential pieces of data are required:

A- The rotational input speed to the gear reducer (n_1) and the rotational output speed (n_2). Through these two values it is possible to calculate the reduction ratio (i) of the gear reducer using the following formula:

$$i = \frac{n_1}{n_2}$$

B- The torque required by the application (MH). The geared motor or gear reducer can be selected once this data is known.

Geared motor selection

This guide indicates a brief sequence of steps for selecting a suitable product:

1. Determine the application's actual service factor (f_b). This parameter depends on the type of load of the powered machine, the number of starts per hour and the hours of operation (refer to the "Service factor" paragraph on page 8)
2. Calculate the input power PH using the required torque value MH, the speed n_2 and dynamic efficiency value. The dynamic efficiency value depends on the type of gear reducer and on the number of gear reduction stages.
D/M Parallel shaft mounted gear unit have an average value equal to (η_d):
D/M... 2 stages = 0,96
3 stages = 0,94

$$PH = \frac{MH \cdot n_2}{9550 \cdot \eta_d}$$

3. Consult the geared motor performance tables and identify a normalised power value P1 exceeding the required power PH, such that:

$$P_1 \geq PH$$

4. Once the suitable normalised power has been identified, select the geared motor capable of generating the rotational speed closest to the desired n_2 value and with service factors f_b greater or equal to that required by the application.

In the geared motor selection tables the combinations include 2-pole, 4-pole and 6-pole motors powered at 50Hz; for different drive speeds refer to the nominal data provided for the gear reducers.

IT INFORMAZIONI TECNICHE

Per la corretta selezione di un riduttore o di un motoriduttore occorre disporre di alcuni dati fondamentali quali:

A- La velocità angolare in entrata al riduttore (n_1) e la velocità angolare in uscita (n_2). Attraverso questi due valori è possibile calcolare il rapporto di riduzione (i) del riduttore attraverso la formula:

$$i = \frac{n_1}{n_2}$$

B- Il momento torcente richiesto dall'applicazione (MH).

Noti questi dati, si può procedere nella selezione del motoriduttore o del riduttore.

Selezione dei motoriduttori

Questa guida conduce alla selezione del prodotto attraverso pochi passi:

1. Determinare il fattore di servizio effettivo dell'applicazione (f_b). Questoparametro è funzione del tipo di carico della macchina azionata, del numero di azionamenti per ora e del numero di ore di funzionamento (vedi paragrafo "Fattore di servizio" pag. 8).
2. Ricavare la potenza in entrata PH mediante il momento torcente richiesto MH, la velocità n_2 e il rendimento dinamico. Il valore di rendimento dinamico dipende dalla tipologia del riduttore e dal numero di stadi d'ingranaggi di riduzione. I riduttori ortogonali della serie D/M presentano unvalore medio pari a (η_d):
D/M...2 stadi = 0,96
3 stadi = 0,94

$$PH = \frac{MH \cdot n_2}{9550 \cdot \eta_d}$$

3. Consultare le tabelle delle prestazioni dei motoriduttori ricercando una potenza normalizzata P1 superiore a quella richiesta PH tale che:

$$P_1 \geq PH$$

4. Individuata la potenza normalizzata idonea, selezionare dunque il motoriduttore in grado di sviluppare la velocità angolare più vicina a quella n_2 desiderata e con fattore di servizio f_b maggiore o uguale richiesto dall'applicazione.

Nelle tabelle di selezione dei motoriduttori gli abbinamenti sono realizzati con motori 2,4,6 poli alimentati a 50Hz, per velocità di azionamento diverse riferirsi ai dati nominali forniti per i riduttori.

FR

INFORMACION TECNICA

Pour choisir correctement un réducteur ou un motorréducteur, il est nécessaire de disposer de certaines données fondamentales telles que:

A- La vitesse angulaire en entrée du réducteur (n1) et la vitesse angulaire en sortie (n2). Grâce à ces deux valeurs, il est possible de calculer le rapport de réduction (i) du réducteur en utilisant la formule:

$$i = \frac{n1}{n2}$$

B- Le moment de torsion requis par l'application (MH)

Une fois ces données, il est possible de procéder au choix du motorréducteur ou du réducteur.

Selection des motoréducteur

Ce guide permet de procéder à la sélection du produit en suivant quelques étapes:

1. Déterminer le facteur de service effectif de l'application (fs). Ce paramètre dépend du nombre d'actionnements par heure et du nombre d'heures de fonctionnement (voir paragraphe "Facteur de service" page 8).
2. Déterminer la puissance en entrée PH à l'aide du moment de tension requis MH de la vitesse n2 et du rendement dynamique.
La valeur du rendement dynamique dépend du type de réducteur et du nombre de trains d'engrenages de réduction. Les réducteurs orthogonaux de la série D/M présentent une valeur moyenne égale à (ηd):
D/M...2 trains = 0,96
3 trains = 0,94

$$PH = \frac{MH \cdot n2}{9550 \cdot \eta d}$$

3. Consulter le tableau des performances des motoréducteurs en recherchant une puissance normalisée PH supérieure la puissance P1 demandée telle que:

$$P1 \geq PH$$

4. Une fois identifiée la puissance normalisée adéquate, sélectionner le motoréducteur en mesure de développer la vitesse angulaire la plus proche de la vitesse n2 désirée et présentant un facteur de service fs supérieur ou égal à celui demandé par l'application.

Dans les tableaux de sélection des motoréducteurs, les combinaisons sont réalisées avec des moteurs 2,4,6 pôles alimentés à 50Hz. Pour des vitesses d'actionnement différentes, se référer aux données nominales fournis par les réducteurs

ES

INFORMACIÓN TÉCNICO

Para la correcta selección de un reductor o de un motorreductor es necesario disponer de algunos datos fundamentales como:

A- La velocidad angular a la entrada del reductor (n1) y la velocidad angular a la salida (n2). A través de reducción (i) del reductor utilizando la fórmula:

$$i = \frac{n1}{n2}$$

B- El momento de torsión requerido por la aplicación (MH).

Conocidos estos datos, se puede proceder a la selección del motorreductor o del reductor.

Selección de los motorreductores

Esta guía conduce a la selección del producto a través de unos pocos pasos:

1. Determinar el factor de servicio efectivo de la aplicación (fs). Este parámetro es función del tipo de carga de la máquina accionada, del número de accionamientos por hora y de la cantidad de horas de funcionamiento (ver el párrafo "Factor de servicio" pág.8).
2. Obtener la potencia a la entrada PH utilizando el momento de torsión requerido MH, la velocidad n2 el rendimiento dinámico.
El valor del rendimiento dinámico depende del tipo de reductor y del número de etapas de engranajes de reducción. Los reductores ortogonales de la serie D/M presentan un valor medio igual a (ηd):
D/M...2 trenes = 0,96
3 trenes = 0,94

$$PH = \frac{MH \cdot n2}{9550 \cdot \eta d}$$

3. Consultar las tablas de las prestaciones de los motorreductores buscando una potencia normalizada P1 superior a la requerida PH tal que:

$$P1 \geq PH$$

4. Una vez identificada la potencia normalizada adecuada, seleccionar el motorreductor capaz de desarrollar la velocidad angular más cercana a la n2 deseada y con un factor de servicio fs mayor o igual que el necesario para la aplicación

En las tbles de selección de los motorreductores, las combinaciones se realizan con motores de 2,4,6 polos alimentados con 50Hz. Para velocidades de accionamiento diferentes, consultar los datos nominales suministrados para los reductores.

DE TECHNISCHE INFORMATIONEN

Auswahl der Getriebe

1. Den Betriebsfactor der Anwendung bestimmen (f_b) (siehe Absatz "Betriebsfactor" S.8).
2. Das benötigte Übersetzungsverhältnis i aus der erforderlichen Abtriebsdrehzahl n_2 und der Antriebsdrehzahl n_1 bestimmen.

$$i = \frac{n_1}{n_2}$$

3. Das Drehmoment M_G für die Auswahl des Getriebes über das von der Anwendung erforderliche Drehmoment M_H und den Betriebsfaktor f_b ermitteln:

$$M_G = M_H \cdot (f_b)$$

4. Das Getriebe mit dem Übersetzungsverhältnis aus der tabelle der Getriebedaten auswählen, das dem bestimmten Übersetzungsverhältnis am nächsten kommt und über ein ausreichendes Nenn Drehmoment M_2 verfügt, sodass:

$$M_2 \geq M_G$$

Überprüfungen

Nach der Auswahl des Getriebes oder des Getriebemotors ist es ratsam, die folgenden Überprüfungen durchzuführen:

A Thermische Leistung

Die thermische Leistung des Getriebes muss gleich oder größer als die installierte mechanische Leistung sein oder als die von der Anwendung gemäß den im Abschnitt anhaltenen Angaben erforderliche Leistung (siehe Abschnitt "thermische Leistung" S.12).

B Maximales Drehmoment

Grundsätzlich darf das maximale Drehmoment (momentane Spitzenbelastung), das an das Getriebe angewendet werden kann, nicht mehr als 200% des Nenn Drehmoments M_2 betragen.

C Radiale Belastungen

Überprüfen Sie bitte das die radialen Belastungen auf den Eingangs- und / oder Ausgangswellen die zu gelassenen Katalogwerte nicht überschreiten. Wenn diese größer sind, bitte die Getriebegröße anpassen oder die Auslegung für die externe Last anpassen. In der Prüfphase berücksichtigen bitte berücksichtigen, dass die im Katalog angegebenen Werte sich auf Lasten beziehen, die auf die Mittelachse des Wellenüberstands wirken. Daher ist es notwendig mit den entsprechenden Formeln die zugelassene Last in der gewünschten Position zu bestimmen, falls diese in einer davon abweichenden Position angebracht wird (siehe Absatz "Radiale Belastungen S. 20).

EN TECHNICAL INFORMATION

Gear reducer selection

1. Determine the application's service factor (f_b) (consult to the "Servico factor" paragraph on page 8).
2. Calculate the reduction ratio i from the requested output speed n_2 and from the input speed n_1 .

$$i = \frac{n_1}{n_2}$$

3. Calculate the torque M_G for selecting the gear reducer through the torque required by the application M_H and the service factor f_b :

$$M_G = M_H \cdot (f_b)$$

4. Consult the gear reducer performance tables and identify the gear reducer that - with a reduction ratio closest to the calculated ratio - has a nominal torque M_2 such that

$$M_2 \geq M_G$$

Checks

Once the gear reducer or geared motor has been selected, the following checks should be performed:

A Thermal Power

The gear reducer's thermal power must be equal to or greater than the installed mechanical power, or the power required by the application according to the indications contained in the section (refer to the "Thermal power" paragraph on page 12).

B Maximum Torque

Generally, the maximum torque (peak instantaneous load) that can be applied to the gear reducer must not exceed 200% of the nominal torque M_2 .

C Radial Loads

Verify that the loads acting on the input and /or output shaft are within with the values indicated in the catalogue. If they exceed these values, increase the size of the gear reducer or modify the external load capacity. During the checking phase, it is important to remember that the values indicated in the catalogue refer to loads acting on the mid-point of the shaft protrusion, therefore, if the load is applied to a different position, appropriate formulas must be used to calculate the admissible load in the desired position (refer to the "Radial loads" paragraph on page 20).

IT GUIDA ALLA SELEZIONE DI PRODOTTO

Selezione dei riduttori

1. Determinare il fattore di servizio dell'applicazione (f_b) (vedi paragrafo "Fattore di servizio" pag.8)
2. Calcolare il rapporto di riduzione i dalla velocità in uscita n_2 richiesta e dalla quella in entrata n_1 .

$$i = \frac{n_1}{n_2}$$

3. Ricavare il momento torcente M_G per la selezione del riduttore attraverso la coppia richiesta dall'applicazione M_H ed il fattore di servizio f_b :

$$M_G = M_H \cdot (f_b)$$

4. Consultare le tabelle delle prestazioni dei riduttori cercando il riduttore che, col rapporto di riduzione più prossimo a quello calcolato, dispone di una coppia nominale M_2 tale che:

$$M_2 \geq M_G$$

Verifiche

Eseguita la selezione del riduttore o del motoriduttore è opportuno effettuare le seguenti verifiche:

A Potenza Termica

La potenza termica del riduttore deve essere uguale o maggiore della potenza meccanica installata o della potenza richiesta dall'applicazione secondo le indicazioni contenute nella sezione (vedi paragrafo "Potenza termica" pag 13).

B Coppia Massima

Generalmente la coppia massima (picco di carico istantaneo) che può essere applicata al riduttore non deve superare il 200% della coppia nominale M_2 .

C Carichi radiali

Verificare che i carichi radiali agenti sugli alberi di entrata e/o di uscita rispetto i valori ammessi a catalogo. Se superiori, aumentare la grandezza del riduttore o modificare la supportazione del carico esterno. Nella fase di verifica occorre tenere conto che i valori indicati a catalogo si riferiscono a carichi agenti sulla mezzeria della sporgenza dell'albero per cui, nel caso il carico sia applicato in posizione diversa è necessario determinare con le apposite formule il carico ammissibile nella posizione desiderata (vedi paragrafo "Carichi Radiali" pag 21).

FR GUIDE DE SÉLECTION DU PRODUIT

Sélection des réducteurs

1. Déterminer le facteur de service de l'application (f_B) (voir paragraphe "Facteur de service" page 8).
2. Calculer le rapport de réduction (i) à partir de la vitesse n_2 requise en sortie et de la vitesse en entrée n_1

$$i = \frac{n_1}{n_2}$$

3. Déterminer le moment de torsion MG pour la sélection du réducteur à l'aide du couple MH requis par l'application et du facteur de service f_B :

$$MG = MH \cdot (f_B)$$

4. Consulter les tableaux des performances des réducteurs en recherchant le réducteur disposant du rapport de réduction le plus proche du rapport calculé et présentant un couple nominal M_2 tel que:

$$M_2 \geq MG$$

Vérifications

Une fois sélectionné le réducteur ou le motorréducteur, il convient d'effectuer les vérifications suivantes:

A Puissance Thermique

La puissance thermique doit être égale ou supérieure à la puissance mécanique installée, ou à la puissance requise par l'application, conformément aux indications contenues dans la section (voir paragraphe "Puissance thermique" page 13).

B Couple Maximal

Généralement, le couple maximal (pic de charge instantanée) pouvant être appliqué au réducteur, ne doit pas dépasser 200% du couple nominal M_2 .

C Charges Radiales

Vérifier que les charges radiales agissant sur les arbres d'entrée et/ou de sortie respectent les valeurs admises dans le catalogue. Si elles sont supérieures, augmenter la taille du réducteur ou modifier le palier de la charge extérieure.

Durant la phase de vérification, il est nécessaire de tenir compte du fait que les valeurs indiquées dans le catalogue se réfèrent à des charges agissant sur la moitié de la partie saillante de l'arbre; par conséquent, en cas d'application de la charge dans une position différente, il est nécessaire de déterminer la charge admissible dans la position désirée à l'aide des formules spéciales (voir paragraphe "Charges radiales" page 21).

ES GUÍA PARA LA SELECCIÓN DEL PRODUCTO

Selección de los reductores

1. Determinar el factor de servicio de la aplicación (f_B) (ver el párrafo "Factor de servicio" pág.8).
2. Calcular la relación de reducción i entre la entrada la velocidad de salida n_2 requerida y la de entrada n_1

$$i = \frac{n_1}{n_2}$$

3. Obtener el momento de torsión MG para seleccionar el reductor a través del par necesario para la aplicación MH y el factor de servicio f_B :

$$MG = MH \cdot (f_B)$$

4. Consultar las tables de las prestaciones de los reductores buscando el reductor que, con la relación de reducción más próxima a la calculada, disponga de un par nominal M_2 tal que:

$$M_2 \geq MG$$

Verificaciones

Una vez realiza la selección del reductor o del motorreductor es conveniente efectuar las siguientes verificaciones:

A Potencia Térmica

La potencia térmica del reductor debe ser mayor o igual que la potencia mecánica instalada o que la potencia requerida por la aplicación según las indicaciones contenidas en la sección (ver el párrafo "Potencia térmica" pág 13).

B Par Máximo

Generalmente el par máximo (pico de carga instantáneo) que se puede aplicar al reductor no debe superar el 200% del par nominal M_2 .

C Cargas Radiales

Verificar que las cargas radiales que actúan sobre los árboles de entrada y/o de salida respeten los valores admitidos según el catálogo. Si son mayores, aumentar el tamaño del reductor o modificar la capacidad de soportar la carga externa. En la fase de verificación, es necesario tener en cuenta que los valores indicados en el catálogo se refieren a carga está aplicada en una posición diferente, es necesario determinar la carga admisible en la posición deseada con las fórmulas correspondientes (ver el párrafo "Cargas Radiales" pág. 21).

DE **BETRIEBSFAKTOR**

Der Betriebsfaktor (fb) hängt von den Betriebsbedingungen, ab, unter denen das Getriebe betrieben wird. Die Parameter, die für eine korrekte Auswahl des Betriebsfaktors zu berücksichtigen sind, sind folgende:

- Belastungsart der angetriebenen Maschine: **U - M - H**
- Tägliche Betriebsdauer: **Std./Tag**
- Anlaufrequenz: **Anl./Std.**

LAST:	U- Gleichförmig	mfa ≤ 0.3
	M- Mittlere Überlast	mfa ≤ 3
	H- Hohe Überlast	mfa ≤ 10

mfa = Je/Jm

- mfa Massenträgheitswert
 - Je (kgm²) äußeres Trägheitsmoment reduziert auf die Motorwelle
 - Jm (kgm²) Motor-Trägheitsmoment
- Bei mfa>10 bitte mit unserem Kundendienst Kontakt aufnehmen.

U- Schneckenförderer für Leichtmaterial, Gebläse, Montagebänder, Bandförderer für Leichtmaterial, kleine Rührwerke, Kleinlastenaufzüge, Kreiselpumpen, Hebebühnen, Reinigungsmaschinen, Abfüllmaschinen, Prüfmaschinen, Bandförderer.

M- Wickelmaschinen, Vorrichtungen zur Zuführung bei Holzbearbeitungsmaschinen, Lastaufzüge, Auswuchtmaschinen, Gewindeschneidmaschinen, mittlere Rührwerke und Mischer, Bandförderer für schwere Materialien, Winden, Schiebetore, Dünger Abkratzer, Verpackungsmaschinen, Betonmischmaschinen, Kranfahrund Kranhubwerke, Fräsmaschinen, Biegemaschinen, Zahnradpumpen, Hubstapler, Drehtische.

H- Rührwerke für schwere Materialien, Scheren, Pressen, Schleudern, Winden und Aufzüge für schwere Materialien, Schleifmaschinen, Steinbrecher, Kettenbecherwerke, Bohrmaschinen, Hammernmühlen, Exzenterpressen, Biegemaschinen, Drehtische, Scheuertrommeln, Vibrationsrüttler, Schneidemaschinen, Stanzen, Walzwerke, Zementmühlen.

EN **SERVICE FACTOR**

The service factor (fb) depends on the operating conditions the reduction unit is subjected to. The parameters that need to be taken into consideration to select the most adequate service factor correctly comprise:

- Type of load of the operated machine: **U - M - H**
- Length of daily operating time: **hours/day**
- Start-up frequency: **starts/hour**

TYPE OF LOAD:	U- Uniform	mfa ≤ 0.3
	M- Moderate shocks	mfa ≤ 3
	H- Heavy shocks	mfa ≤ 10

mfa = Je/Jm

- mfa factor of inertia
 - Je (kgm²) moment of reduced external inertia at the drive shaft
 - Jm (kgm²) moment of inertia of motor
- If mfa > 10 call our Technical Service.

U- Screw feeders for light materials, fans, assembly lines, conveyor belts for light materials, small mixers, lifts, cleaning machines, fillers, control machines.

M- Winding devices, woodworking machine feeders, goods lifts, balancers, threading machines, medium mixers, conveyor belts for heavy materials, winches, sliding doors, fertilizer scrapers, packing machines, concrete mixers, crane mechanisms, milling cutters, folding machines, gear pumps.

H- Mixers for heavy materials, shears, presses, centrifuges, rotating supports, winches and lifts for heavy materials, grinding lathes, stone mills, bucket elevators, drilling machines, hammer mills, cam presses, folding machines, turntables, tumbling barrels, vibrators, shredders.

IT **FATTORE DI SERVIZIO**

Il fattore di servizio (fb) dipende dalle condizioni di funzionamento alle quali il riduttore è sottoposto.

I parametri che occorre considerare per una corretta selezione del fattore di servizio più adeguato sono:

- Tipo del carico della macchina azionata: **U-M-H**
- Durata di funzionamento giornaliero: **ore/giorno**
- Frequenza di avviamento: **avv/ora**

TIPO DEL CARICO:	U - Uniforme	mfa ≤ 0.3
	M - Medio	mfa ≤ 3
	H - Forte	mfa ≤ 10

mfa = Je/Jm

- mfa fattore d'inerzia
 - Je (kgm²) momento d'inerzia esterno ridotto all'albero motore
 - Jm (kgm²) momento d'inerzia motore
- Se mfa > 10 interpellare il ns. Servizio Tecnico.

U- Coclee per materiali leggeri, ventole, linee di montaggio, nastri trasportatori per materiali leggeri, piccoli agitatori, elevatori, macchine pulitrici, macchine riempitrici, macchine per il controllo, nastri trasportatori.

M- Dispositivi di avvolgimento, apparecchi per l'alimentazione delle macchine per il legno, montacarichi, equilibratrici, filettatrici, agitatori medi e mescolatori, nastri trasportatori per materiali pesanti, verricelli, porte scorrevoli, raschiatore di concime, macchine per l'imballaggio, betoniere, meccanismi per il movimento delle gru, frese, piegatrici, pompe a ingranaggi.

H- Agitatori per materiali pesanti, cesoie, prese, centrifughe, supporti rotanti, verricelli ed ascensori per materiali pesanti, torni per la rettifica, frantoi da pietre, elevatori a tazze, perforatrici, mulini a meartello, presse as eccentrico, piegatrici, tavoli rotanti, barilatrici, vibratori, trinciatrici.

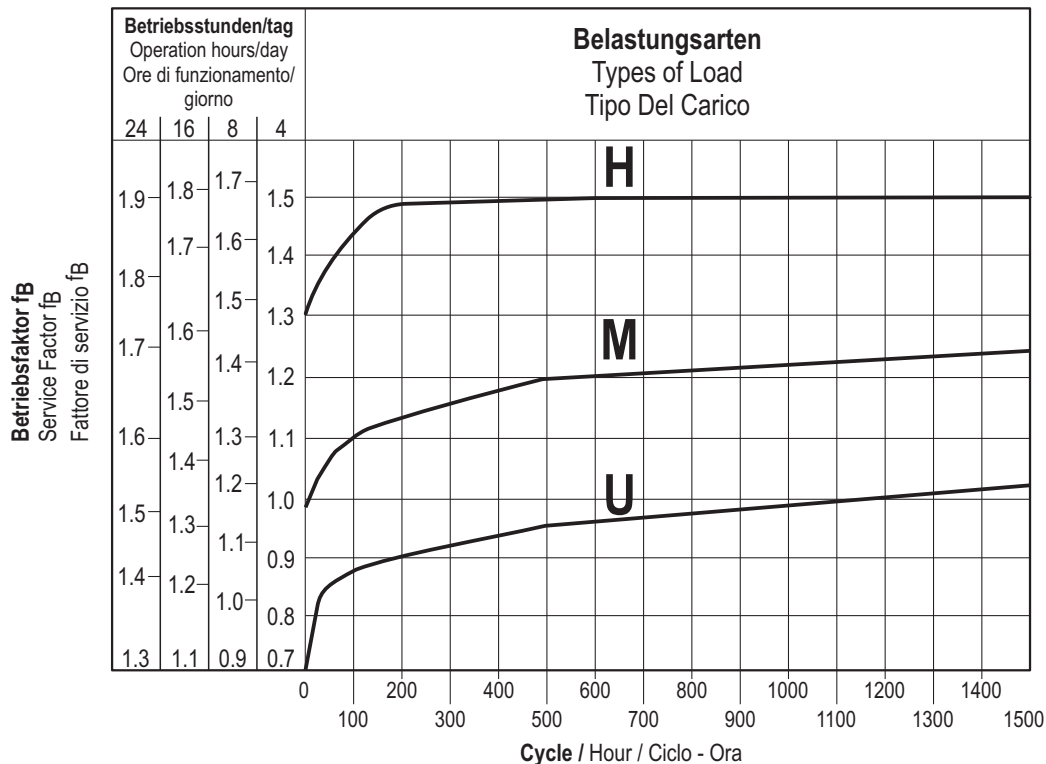

FR

FACTEUR DE SERVICE

Le facteur de service (f_b) est subordonné aux conditions de fonctionnement auxquelles le réducteur est soumis. Les paramètres qu'il faut considérer pour un choix correct du facteur de service adéquat sont les suivants:

- Type de charge de la machine actionnée: **U-M-H**
- Durée de fonctionnement journalière: **heures / jour**
- Fréquence de démarrage: **dém / heure**

TYPE DE CHARGE: **U** - Uniforme $mfa \leq 0.3$
M - Surcharge moyenne $mfa \leq 3$
H - Surcharge forte $mfa \leq 10$

$mfa = Je/Jm$

- mfa facteur d'inertie
 - Je (kgm^2) moment d'inertie extérieur ramené à l'arbre-moteur
 - Jm (kgm^2) moment d'inertie moteur
- En cas de $mfa > 10$, contacter notre S.c.e Technique.

U- Vis d'Archimède pour matériaux légers, ventilateurs, lignes de montage, convoyeurs pour matériaux légers, petits agitateurs, élévateurs, machines à nettoyer, machines à remplir, machines pour le contrôle, convoyeurs.

M- Dispositifs d'enroulement, appareils pour l'alimentation des machines pour le bois, monte- charges, équilibreuse, taraudeuses, agitateurs moyens et mélangeurs, convoyeurs pour matériaux lourds, treuils, portes coulissantes, racleurs d'engrais, machines à emballer, plieuses, pompes à engrenages.

H- Agitateurs pour matériaux lourds, cisailles, presses, centrifugeuses, supports rotatifs, treuils et ascenseurs pour matériaux lourds, tours pour la rectification, concasseurs de pierres, élévateurs à godets, perceuses, moulins à marteaux, presses à excentrique, plieuses, tables tournantes, polisseuses, vibreurs, machines à hacher.

ES

FACTOR DE SERVICIO

El factor de servicio (f_b) depende de las condiciones de funcionamiento a las cuales está sometido el reductor. Los parámetros que deben ser considerados para una correcta selección del factor de servicio más adecuado son:

- Tipo de carga de la máquina accionada: **U-M-H**
- Duración de funcionamiento diario: **horas/día**
- Frecuencia de arranques: **arr/hora**

TIPO DE CARGA: **U** - Uniforme $mfa \leq 0.3$
M - Sobrecarga media $mfa \leq 3$
H - Sobrecarga fuerte $mfa \leq 10$

$mfa = Je/Jm$

- mfa factor de inercia
 - Je (kgm^2) inercia externa reducida al eje motor
 - Jm (kgm^2) inercia motor
- En caso de $mfa > 10$, ponerse en contacto con nuestro Servicio Técnico.

U- Tornillos de Arquímedes para materiales ligeros, ventiladores, líneas de montaje, cintas transportadoras para materiales ligeros, pequeños agitadores, elevadores, máquinas limpiadoras, máquinas llenadoras, máquinas comprobadoras, cintas transportadoras.

M- Dispositivos de enrollado, alimentadores de las máquinas para la madera, montacargas, equilibradores, roscadoras, agitadores medios y mezcladores, cintas transportadoras para materiales pesados, cabrestantes, puertas corredizas, raspadores de abono, máquinas empaquetadoras, puertas corredizas, raspadores de abono, máquinas empaquetadoras, hormigoneras, mecanismos para el movimiento de las grúas, fresadoras, plegadoras, bombas de engranajes.

H- Agitadores para materiales pesados, cizallas, prensas, centrifugadoras, soportes rotativos, cabrestantes y elevadores para materiales pesados, tornos para la rectificación, molinos de piedras, elevadores de cangilones, perforadoras, molidores a percusión, prensas de excéntrica, plegadoras, mesas giratorias, pulidoras, vibradores, cortadoras.

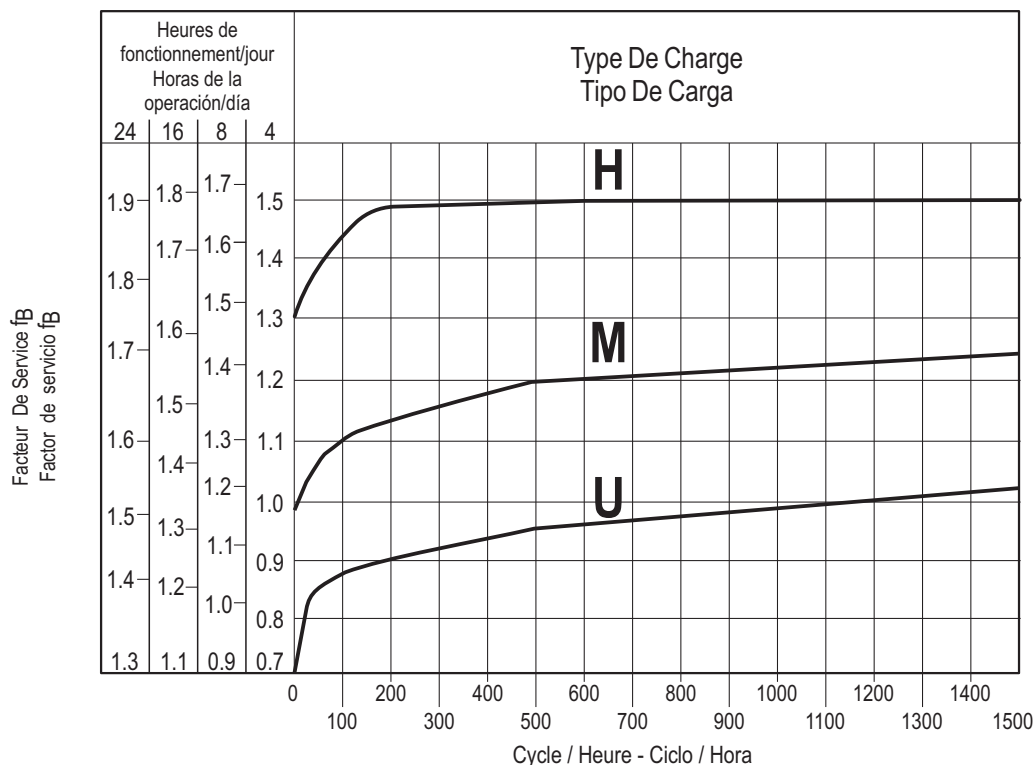

DE KRITISCHE ANWENDUNGEN

Die im Katalog aufgeführten Leistungsdaten gelten für die Einbaulage M1 oder gleichwertig, wenn das Ritzel nicht völlig mit Öl geschmiert wird.

Für andere Einbaulagen und / oder besondere Antriebsdrehzahlen sind die Tabellen zu beachten, die verschiedene kritische Zustände für jede Getriebegröße darstellen. Darüber hinaus sind nachstehende Anwendungen zu beachten und eventuell sollte mit unserem Kundendienst Kontakt aufgenommen werden:

- Einsatz als Übersetzungsgetriebe (Übersetzung ins Schnelle).
- Anwendungen, die bei Bruch des Getriebes für den Menschen gefährlich sein könnten.
- Anwendungen mit sehr hohen Trägheitsmomenten.
- Einsatz als Hebewinde.
- Anwendungen mit hohen dynamischen Beanspruchungen auf Getriebegehäuse.
- Einsatz bei Umgebungstemperaturen unter -5°C oder über 40°C.
- Einsatz in Verbindung mit aggressiven chemischen Substanzen.
- Einsatz unter Salzwassereinwirkung.
- Nicht im Katalog vorgesehene Einbaulagen.
- Einsatz unter radioaktiver Strahlung.
- Einsatz unter einem Druck, der nicht dem normalem Luftdruck entspricht.

Anwendungen, bei denen das Eintauchen des Getriebes in Wasser vorgesehen ist (auf teilweise), sollen vermieden werden. Das max. zulässige Drehmoment; (*) des Getriebes, darf nicht den zweifachen Wert des in der Leistungstabelle angegebenen nominalen Wert des Drehmomentes ($f_B=1$) übersteigen.

(*) Hierbei sind Überlasten gemeint, welche durch Anlaufen unter Vollast, Bremsungen, Stöße und weiter dynamische Ursachen, hervorgerufen werden.B

EN CRITICAL APPLICATIONS

The performance given in the catalogue correspond to mounting position M1 or similar, ie. when the first stage is not entirely immersed in oil.

For other mounting positions and/or particular input speeds, refer to the tables that highlight different critical situations for each size of reduction unit.

It is also necessary to take due consideration of and carefully assess the following applications by calling our Technical Service:

- As a speed increasing.
- Use in services that could be hazardous for people if the reduction unit fails.
- Applications with especially high inertia.
- Use as a lifting winch.
- Applications with high dynamic strain on the case of the reduction unit.
- In places with T° under -5°C or over 40°C.
- Use in chemically aggressive environments.
- Use in a salty environment.
- Mounting positions not envisaged in the catalogue.
- Use in radioactive environments.
- Use in environments pressures other than atmospheric pressure.
- Avoid applications where even partial immersion of the reduction unit is required.

The maximum torque; (*) that the gear reducer can support must not exceed two times the nominal torque ($f_B=1$) stated in the performance tables. (*) intended for momentary overloads due to starting at full load, braking, shocks or other causes, particularly those that are dynamic.

IT APPLICAZIONI CRITICHE

Le prestazioni indicate a catalogo corrispondono alla posizione M1 o similari, quando cioè il primo stadio non è interamente immerso in olio. Per situazioni di pizamento diverse e/o velocità di ingresso particolari attenersi alle tabelle che evidenziano situazioni critiche diverse per ciascuna taglia di riduttore.

Occorre anche tenere nella giusta considerazione e valutare attentamente le seguenti applicazioni consultando il ns. Servizio Tecnico:

- Utilizzo come moltiplicatore.
- Utilizzo in servizi che potrebbero risultare pericolosi per l'uomo in caso di rottura del riduttore.
- Applicazioni con inerzie particolarmente elevate.
- Utilizzo come argano di sollevamento.
- Applicazioni con elevate sollecitazioni dinamiche sulla cassa del riduttore.
- Utilizzo in ambiente con T° inferiore a -5°C o superiore a 40°C.
- Utilizzo in ambiente con presenza di aggressivi chimici.
- Utilizzo in ambiente salmastro.
- Posizioni di piazzamento non previste a catalogo.
- Utilizzo in ambiente radioattivo.
- Utilizzo in ambiente con pressione diversa da quella atmosferica.

Evitare applicazioni dove è prevista l'immersione, anche parziale, del riduttore.

La coppia massima (*) sopportabile dal riduttore non deve superare il doppio della coppia nominale ($f_B=1$) riportata nelle tabelle delle prestazioni. (*) intesa come sovraccarico istantaneo dovuto a avviamenti a pieno carico, frenature, urti ed altre cause soprattutto dinamiche.

D/M	302-303	352-353	402-403	502-503	602-603
2000 < n1 < 3000	-	-	-	-	-
M2	P	P	P	P	P
n1 > 3000	P	P	P	P	P
... L : M2 - M4	P	P	P	P	P

P Anwendung überprüfen und/oder mit unserem Kundendienst Kontakt aufnehmen.
Check the application and/or call our technical service.
Verificare l'applicazione e/o contattare il ns. servizio tecnico.

FR APPLICATIONS CRITIQUES

Les performances indiquées sur le catalogue correspondent à la position M1 ou similaires, lorsque le premier train d'engrenage n'est pas entièrement immergé dans l'huile. Pour les combinaisons d'assemblage différentes et/ou les vitesses d'entrée particulières, se conformer aux tableaux qui mettent en évidence les différentes situations critiques pour chaque taille de réducteur. Il faut aussi prendre en considération et évaluer attentivement les applications suivantes, en consultant notre S.ce Technique:

- Emploi comme multiplicateur.
- Emploi en services qui pourraient être dangereux pour l'homme en cas de rupture du réducteur.
- Applications avec inerties particulièrement élevées.
- Emploi comme treuil, en cas de soulèvement.
- Applications avec sollicitations dynamiques sur la carcasse du réducteur.
- Emploi en milieu avec température au - dessous de -5°C ou au-dessus de 40°C.
- Emploi en milieu en présence d'agents chimiques agressifs.
- Emploi en milieu saumâtre.
- Positions de montage non prévues sur le catalogue.
- Emploi en milieu radioactif.
- Emploi en milieu ayant une pression différente de celle atmosphérique.

Eviter les applications dans lesquelles l'immersion du réducteur, même si partielle, est prévue.

Le couple maximum (*) supporté par le réducteur ne doit pas être supérieur au double du couple nominal ($f_B=1$) suivant notre table de prestation. (*) Entendu comme surcouple instantané dû à démarrages en pleine charge, freinages, chocs et autres causes surtout dynamiques.

ES APLICACIONES CRITICAS

Las prestaciones indicadas en el catálogo corresponden a la posición M1 o similares, cuando el primer tren de engranajes no está completamente inmerso en el aceite. Para posiciones de montaje distintas y/o de velocidades particulares a la entrada, atenderse a las tablas que ponen en evidencia las distintas situaciones críticas por cada tamaño de reductor. Además es necesario considerar y evaluar cuidadosamente las siguientes aplicaciones, poniéndose en contacto con nuestro Servicio técnico:

- Utilización como multiplicador.
- Utilización en servicios que, en caso de ruptura del reductor, podrían resultar peligrosos para el hombre.
- Aplicaciones con inercias particularmente elevadas.
- Utilización como cabrestante de levantamiento.
- Aplicaciones con esfuerzos dinámicos elevados sobre la carcasa del reductor.
- Utilización en ambiente con T° inferior a -5°C o superior a 40°C.
- Utilización en ambiente con presencia de agentes químicos agresivos.
- Utilización en ambiente salino.
- Posiciones en montaje no previstas en el catálogo.
- Utilización en ambiente radioactivo.
- Utilización en ambiente con presión distinta de la atmosférica.

Evitar aplicaciones donde es prevista la inmersión, aún parcial, del reductor.

El par máximo (*) soportable por el reductor no debe superar el doble del par nominal ($f_B=1$) indicado en la tabla de prestaciones. (*) Entendida como sobrecarga instantánea debida a puestas en marcha a plena carga, frenados, impactos y otras causas sobretodo dinámicas.

D/M	302-303	352-353	402-403	502-503	602-603
2000 < n1 < 3000	-	-	-	-	-
M2	P	P	P	P	P
n1 > 3000	P	P	P	P	P
... L : M2 - M4	P	P	P	P	P

P Verifier l'application et/ou contacter notre s.ce technique.
Controlar la aplicación y/o ponerse en contacto con nuestro servicio técnico.

DE THERMISCHE LEISTUNG Pt [kW]

Die folgende Tabelle enthält die Werte der thermischen Nennleistung in kW unter den folgenden Referenzbedingungen:

- Montageposition M1
- Dauerbetrieb mit Eingangsgeschwindigkeit <=1500rpm
- Umgebungstemperatur von 25°C
- Höhe über dem Meeresspiegel
- Geschwindigkeit der Luft im Getriebeinneren >=1m/s
- Abwesenheit von radialen und/oder axialen externen Belastungen

EN THERMAL POWER Pt [kW]

The table below list the nominal thermal power values expressed in kW, in the following reference conditions:

- Mounting position M1
- Continuous operation at input speed <=1500 rpm
- Ambient temperature 25°C
- Sea level altitude
- Air speed near the gear reducer >=1m/s
- Absence of external radial and/or axial loads

IT POTENZA TERMICA Pt [kW]

La seguente tabella riporta i valori di potenza termica nominale espressa in kW nelle seguenti condizioni di riferimento:

- Posizione di montaggio M1
- Funzionamento continuo con velocità di entrata <=1500 rpm
- Temperatura ambiente di 25°C
- Altitudine pari al livello del mare
- Velocità dell'intorno del riduttore >=1m/s
- Assenza di carichi radiali e/o assiali esterni

Thermische Leistungen bei 1500 rpm / Thermal power values at 1500 rpm / Potenza termiche a 1500rpm	
Getriebe / Gear reducer / Riduttore	Pt[kW]
D/M 302-303	7
D/M 352-353	9.5
D/M 402-403	15.5
D/M 502-503	20.5
D/M 602-603	34.5

Durch die Anwendung einer die Pt nicht übersteigenden Leistung an das Getriebe wird eine ausreichende Schmierung und eine gute Funktionsweise des Getriebes gewährleistet.

Applying a power level not exceeding Pt - at the above-mentioned reference conditions - guarantees the correct lubrication and efficient operation of the gear reducer.

Applicando al riduttore, nelle suddette condizioni di riferimento una potenza non superiore a Pt, risultano garantiti una corretta lubrificazione ed il buon funzionamento del riduttore.

Prüfung der Anwendung

Mit Ausnahme von durchgängigen Betriebszeiten unter zwei (2) Stunden und anschließenden Pausen, bei denen das Getriebe auf die Umgebungstemperatur abkühlt, ist es ratsam bei jeder Anwendung die thermische Grenze des Getriebes mit der folgenden Formel zu überprüfen:

$$P1 < Pt * Fc * Fv * Fa$$

Dabei ist :
 P1 = Eingangleistung des Getriebes 1400 rpm (Motor mit 4 Polen)
 Pt = Thermische Leistung unter Referenzbedingungen (siehe Tabelle oben)
 Fc = Korrekturfaktor für Umgebungstemperatur und Betrieb
 Fv = Korrekturfaktor für Belüftung
 Fa = Korrekturfaktor für Höhe über NN

Die Korrekturfaktoren beziehen sich auf Betriebsbedingungen, die von den Referenzbedingungen abweichen und werden in den folgenden ISO14179- Tabellen aufgeführt:

Application check

Except for continuous operating times below two (2) hours and successive pauses capable of bringing the gear reducer back to ambient temperature, for each application it is advisable to verify the gear reducer's thermal limit according to the following formula:

$$P1 < Pt * Fc * Fv * Fa$$

Where:
 P1 = Input power to the gear reducer at 1.400 rpm (4-pole motors)
 Pt = Thermal power at reference conditions (see above table)
 Fc = Ambient and operating temperature correction factor
 Fv = Ventilation correction factor
 Fa = Altitude correction factor

The correction factors refer to different operating conditions compared to the reference conditions, and are provided by following ISO 14179 tables:

Verifica della applicazione

Fatta eccezione per tempi di funzionamento continuo inferiori a due (2) ore e successive pause in grado di riportare il riduttore a temperatura ambiente, per ogni applicazione è consigliabile eseguire la verifica del limite termico del riduttore, secondo la seguente formula:

$$P1 < Pt * Fc * Fv * Fa$$

Dove:
 P1 = Potenza in ingresso al riduttore a 1400 rpm (motori a 4 poli)
 Pt = Potenza termica in condizioni di riferimento (vedi tabella sopra)
 Fc = Fattore correttivo di temperatura ambiente e servizio
 Fv = Fattore correttivo di aerazione
 Fa = Fattore correttivo dell'altitudine

I fattori correttivi sono relativi a condizioni operative differenti da quelle di riferimento, e sono forniti dalle seguenti tabelle ISO14179:

FR PUISSANCE THERMIQUE Pt [kW]

Le tableau suivant présente les valeurs de puissance thermique nominale exprimées en kW dans les conditions de référence suivantes:

- Position de montage M1
- Fonctionnement continu avec vitesse d'entrée <= 1500tr/min
- Température ambiante de 25°C
- Altitude égale au niveau de la mer
- Vitesse de l'air à proximité du réducteur >= 1m/s
- Absence de charges radiales et/ou axiales externes

ES POTENCIA TÉRMICA Pt [kW]

La siguiente tabla contiene los valores de potencia térmica nominal expresada en kW en las siguientes condiciones de referencia:

- Posición de montaje M1
- Funcionamiento continuo con velocidad de entrada <=1500 rpm
- Temperatura ambiente de 25°C
- Altura sobre el nivel del mar
- Velocidad del aire en torno al reductor >=1m/s
- Ausencia de cargas radiales y/o axiales externas

Puissances thermiques à 1500 rpm / Potencias térmicas a 1500 rpm	
Réducteur / Reductor	Pt[kW]
D/M 302-303	7
D/M 352-353	9.5
D/M 402-403	15.5
D/M 502-503	20.5
D/M 602-603	34.5

L'application au réducteur d'une puissance inférieure à la Pt, dans les conditions de référence indiquées ci-dessus, garantit une lubrification correcte et le bon fonctionnement du réducteur.

En las condiciones de referencia mencionadas, aplicando al reductor una potencia no mayor que la Pt, se garantiza una correcta lubricación y el buen funcionamiento del reductor.

Vérification de l'application

À l'exception e périodes de fonctionnement continu inférieures à deux (2) heures et de pauses successives permettant au réducteur de redescendre à une température ambiante pour toute application, il est conseillé d'effectuer une vérification de la limite thermique du réducteur, selon la formule suivante

$$P1 < Pt * Fc * Fv * Fa$$

Où:

P1 = Puissance d'entrée au réducteur à 1400tr/min (moteurs à 4 p-pôles)

Pt = Puissance thermique dans les conditions de référence (voir tableau ci-dessus)

Fc = Facteur de correction de température ambiante et de service

Fv = Facteur de correction d'aération

Fa = Facteur de correction de l'altitude

Les facteurs de correction correspondent à des conditions de fonctionnement différentes de celles de référence, et sont fournis par les tableaux ISO14179 suivants:

Controlar la aplicación

Salvo cuando los tiempos de funcionamiento continuo son menores que dos (2) horas y se producen pausas capaces de llevar el reductor a la temperatura ambiente, para cada aplicación es aconsejable realizar la verificación del límite térmico del reductor, según la siguiente fórmula:

$$P1 < Pt * Fc * Fv * Fa$$

Donde:

P1 = Potencia a la entrada del reductor a 1400 rpm (motores de 4 polos)

Pt = Potencia térmica en condiciones de referencia (ver la tabla de arriba)

Fc = Factor de correccion de la temperatura ambiente y servicio

Fv = Factor de corrección de aireación

Fa = Factor de corrección de la altitud

Los factores de corrección son relativos a condiciones operativas diferentes a las de referencia y se encuentran en las siguientes tablas ISO14179:

DE THERMISCHE LEISTUNG Pt [kW]

EN THERMAL POWER Pt [kW]

IT POTENZA TERMICA Pt [kW]

F _c		Betriebszeit in % pro Stunde / Duty per hour of operation % / Servizio a carico ora di funzionamento %				
		100	80	70	40	20
Umgebungstemperatur Ambient temperature Temperatura ambiente	10°C	1.15	1.21	1.32	1.55	2.07
	18°C	1.07	1.12	1.23	1.44	1.93
	25°C	1.00	1.05	1.15	1.35	1.80
	30°C	0.93	0.98	1.07	1.26	1.67
	40°C	0.83	0.87	0.95	1.12	1.49
	43°C	0.75	0.79	0.86	1.01	1.35
	50°C	0.67	0.70	0.77	0.90	1.21

Geschwindigkeit der Umgebungsluft / Ventilation correction factor / Velocità dell'aria ambientale	F _v
Stehende Luft (<0,5 m/s) / Stagnant air (<0,5 m/s) / Aria stagnante (<0,5 m/s)	0.75
Installation in geschlossenen Räumen mit geringer Luftzirkulation / Indoor installation with slight ventilation / Installazione al chiuso con lieve aerazione	1
Installation in geschlossenen Räumen mit guter Luftzirkulation (>1,4 m/s) / Indoor installation with good ventilation (>1,4 m/s) / Installazione al chiuso con aerazione (>1,4 m/s)	1.4
Installation im Freien (>3,7 m/s) / Outdoor installation (>3,7 m/s) / Installazione all'aperto (>3,7 m/s)	1.9

Höhe über NN / Altitude correction factor / Altitudine	F _a
0*	1
750	0.95
1500	0.90
2250	0.85
3000	0.81

* Meeresniveau

* Sea level

* Livello del mare

Im Fall eines Betriebs mit Eingangsgeschwindigkeiten über 2000 rpm oder bei Umgebungstemperaturen über 40°C wird empfohlen, den Kundendienst zu kontaktieren.

In caso of operation at input speeds exceeding 2000 rpm, or ambient temperatures greater than 40°C it is advisable to contact out technical department.

In caso di funzionamento con velocità di ingresso maggiori di 2000 rpm, o temperature ambiente maggiori di 40°C è consigliabile contattare il ns servizio di assistenza.

FR PUISSANCE THERMIQUE Pt [kW]

ES POTENCIA TÉRMICA Pt [kW]

F _c		Facteur de marche par heure de fonctionnement % / Servicio con carga por hora de funcionamiento %				
		100	80	70	40	20
Température ambiante Temperatura ambiente	10°C	1.15	1.21	1.32	1.55	2.07
	18°C	1.07	1.12	1.23	1.44	1.93
	25°C	1.00	1.05	1.15	1.35	1.80
	30°C	0.93	0.98	1.07	1.26	1.67
	40°C	0.83	0.87	0.95	1.12	1.49
	43°C	0.75	0.79	0.86	1.01	1.35
	50°C	0.67	0.70	0.77	0.90	1.21

Vitesse de l'air ambiant / Velocidad del arie ambiental	F _v
Air stagnant (<0,5 m/s) / Aire estancado (<0,5 m/s)	0.75
Installation en intérieur avec une légère aération / Instalación cubierta con poca aireación	1
Installation en intérieur avec une aération correcte (>1,4 m/s) / Instalación cubierta con buena aireación (>1,4 m/s)	1.4
/ Installation en extérieur (>3,7 m/s) / Instalación al aire libre (>3,7 m/s)	1.9

Altitude / Altitud	F _a
0*	1
750	0.95
1500	0.90
2250	0.85
3000	0.81

* Niveau de la mer

* Nivel del mar

En cas de fonctionnement avec des vitesses d'entrée supérieures à 2000 tr/min ou en présence de températures ambiantes supérieures à 40°C, il est conseillé de contacter notre service d'assistance.

En el caso de funcionamiento con velocidades de entrada mayores que 2000 rpm o temperaturas ambiente mayores que 40°C es aconsejable llamar a nuestro servicio de asistencia técnica.

DE MONTAGE DES MOTORS AN DEN PAM-IEC FLANSCH B5

Bei Getrieben, welche ohne motor geliefert werden, sind folgende Vorsichtsmaßnahmen zu beachten, um eine korrekte Montage des Elektromotors zu gewährleisten.

Übereinstimmung der Toleranzen von Welle und Motorflansch überprüfen.

Welle, Passung und Flanschfläche sind sorgfältig von Schmutz, Späne oder Lackresten zu säubern.

Halbkupplung auf Motor (sehen Bild) einsetzen, andernfalls sind die korrekte Ausrichtung und die Toleranz der Paßfeder zu überprüfen. In jedem Fall sind solche Montageverfahren anzuwenden, die Schäden an den Motorlagern ausschließen.

Motor anbauen, wobei es zuerst darauf beachtet werden muß, dass die Halbkupplung auf dem Motor und der elastische

Zwischenring auf der Getriebehalbkupplung frei eingreifen können.

Keine Anpassung der Motorpaßfeder ist in diesem Fall erforderlich.

EN MOTOR MOUNTING WITH PAM-IEC FLANGE B5

When the unit is supplied without motor, it is necessary to follow these recommendation to ensure the correct assembly of the electric motor.

Check that the tolerances for the motor shaft and flange correspond to the "standard".

Carefully clean the shaft, spigot and surfaces of the flange removing traces of paint and dirt, and confirm the key is fitted correctly.

Fit the half coupling / sleeve to the motor shaft (see picture) taking care to ensure the motor shaft and bearings are not damaged by avoiding excessive force and where necessary using assembly equipment.

Place the couplings elastic element on to the motor half coupling and position the motor up to the gear unit ensuring the coupling element is aligned with the driven half coupling. Complete the assembly using the fixing bolts.

Key-ways with tightened tolerances.

IT MONTAGGIO MOTORE SU FLANGE PAM-IEC B5

Quando il gruppo viene fornito senza motore occorre osservare le seguenti raccomandazioni per garantire un corretto montaggio del motore elettrico.

Controllare che le tolleranze dell'albero e della flangia motore siano corrispondenti almeno a una classe di qualità "normale".

Pulire accuratamente l'albero, il centraggio ed il piano della flangia da sporco o tracce di vernice.

Procedere al montaggio del semigiunto (vedifigura) sull'albero del motore elettrico che deve avvenire senza eccessiva forzatura in caso diverso controllare la corretta posizione e la tolleranza della linguetta motore; utilizzare comunque opportuni sistemi che garantiscano un corretto montaggio senza rischiare il danneggiamento dei cuscinetti motore.

Procedere quindi al montaggio del motore completo di semigiunto facendo i denti di trascinamento del semigiunto lato motore con quelli dell'elemento elastico presente sul semigiunto fisso lato riduttore.

Non è previsto nessun adattamento della linguetta motore.

FR INSTALLATION MOTEUR SUR BRIDE PAM-IEC B5

Quand le groupe est fourni sans moteur, observez les recommandations suivantes pour garantir un montage correct du moteur électrique.

Contrôler que les tolérances de l'arbre et de la bride du moteur correspondent au moins à une classe de qualité "normale".

Nettoyer soigneusement l'arbre, le centrage et le plan de la bride des traces de saleté et de peinture. Procéder au montage de demi-accouplement sur l'arbre moteur électrique sans forcer (voir image), dans le cas contraire, vérifier la position correcte et la tolérance de la clavette du moteur.

Utiliser, toutefois, des systèmes appropriés qui garantissent un montage correct sans risquer de détériorer les roulements du moteur.

Procéder de la même façon pour le montage du moteur avec le demiaccouplement coté moteur avec de l'élément élastique du demiaccouplement coté réducteur.

Rainures clavette moteur avec tolérances réduites.

ES MONTAJE DE MOTORES CON BRIDA B5

Sie al equipo se suministra sin motor es preciso observar las siguientes recomendaciones para garantizar un correcto montaje del motor eléctrico.

Verificar que la tolerancia del eje y de la brida motor se correspondan al menos a una clase de calidad "normal".

Limpiar cuidadosamente el eje, el centrage y el plano de asiento de restos de barniz o suciedad.

Proceder al montaje del semiacoplamiento en el eje del motor eléctrico sin excesiva fuerza, si no entra con suavidad verificar la correcta tolerancia de la claveta del motor (ver imagen), utilizar en cualquier caso métodos de montaje que no dañen los rodamientos del motor.

Proceder a continuación al montaje del motor con el semiacoplamiento en el reductor, evitandola interferencia de los dientes del acoplamiento.

No se prevé ninguna adaptación de la claveta del motor.

ELASTISCHE KUPPLUNG / FLEXIBLE JOINT / GIUNTO ELASTICO / ACCOUP. ÉLASTIQUE / ACOPL. ELÁSTICO

D/M...IEC

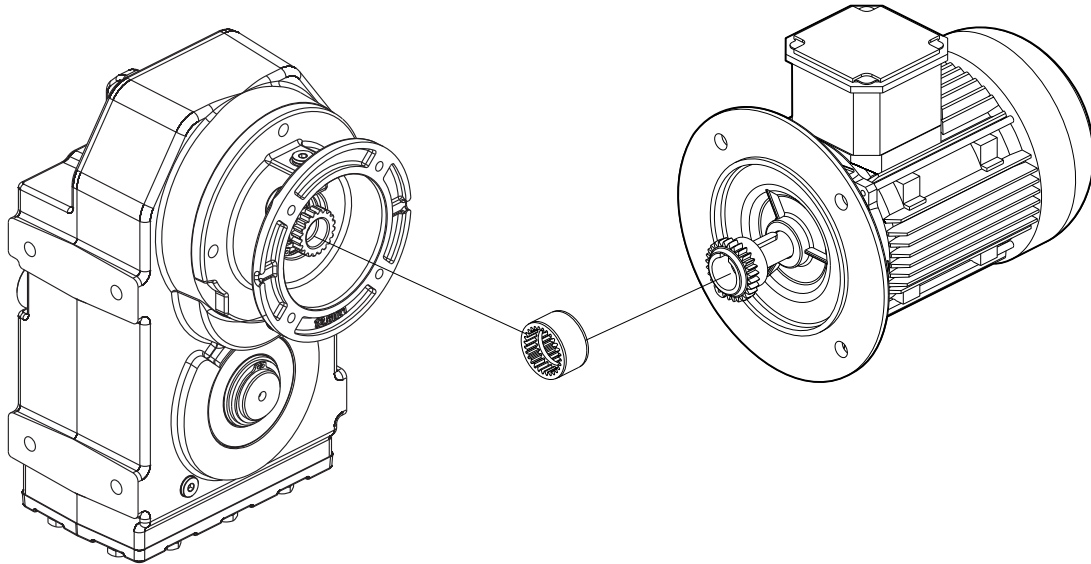

PAM BUCHSE / PAM SLEEVE / MANICOTTO PAM / MANCHON PAM / MANGUÍTO PAM

D/M...PAM

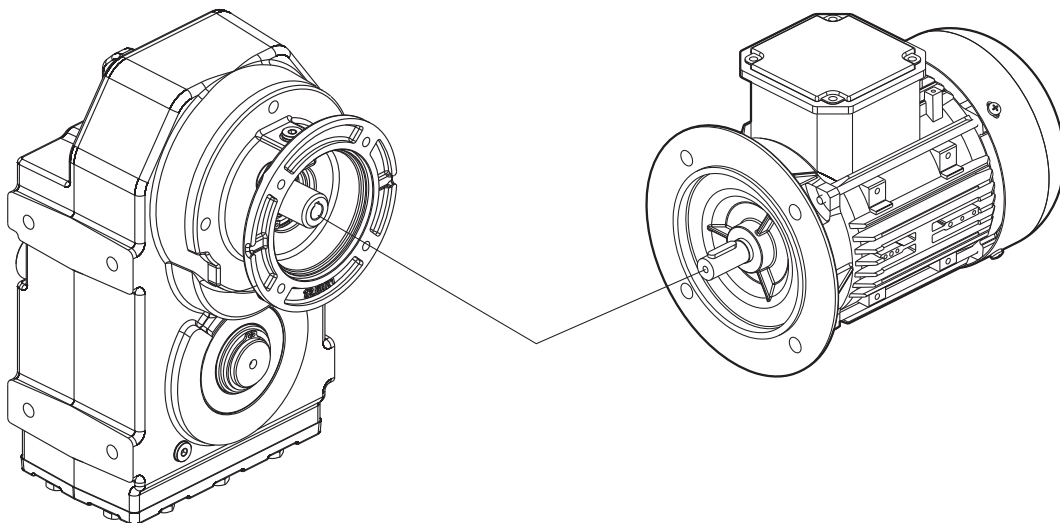

DE MONTAGE

Für die Montage des Getriebes sind nachstehende Anweisungen zu beachten:

- Die Befestigung an der Maschine muß absolut stabil sein, um jegliche Vibrationen zu vermeiden.
- Vor der Montage des Getriebes an der Maschine ist die Abtriebswelle des Getriebes auf die richtige Drehrichtung zu prüfen.
- Nach besonders langer Einlagerung (4/6 Monate) ist zu überprüfen, ob die Wellendichtringe vom Schmiermittel des Getriebes vollständig benetzt wurden; andernfalls ist ein Austausch anzuraten, da die Dichtlippe auf der Welle festkleben kann oder die zum einwandfreien Betrieb notwendige Elastizität nicht mehr vorhanden ist.
- Bei Pendelbefestigung für getriebe mit Abtriebs-hohlwelle sind die von NRW gelieferten Drehmomentstützen zu verwenden; als Alternative muß kundenseitig eine geeignete Drehmomentabstützung erfolgen, wobei hierdurch weder axiale noch Kippmomentbelastungen auf die Lager erzeugt werden dürfen.
- Wenn möglich, sollte das Getriebe vor Sonneneinstrahlung u.a. Witterungseinflüssen geschützt werden.
- Die Motorkühlung muß durch eine gute Belüftung auf der Seite des Lüfters gewährleistet werden.
- Bei Umgebungstemperaturen < -5°C oder > +40°C setzen Sie sich bitte mit dem Kundendienst in Verbindung.
- Zur Montage der unterschiedlichen Anbauteile (Riemenscheiben, Zahnräder, Kupplungen, Wellen usw.) auf den Hohl- oder Vollwellen sind die vorgesehenen Gewindebohrungen oder Aufziehvorrichtungen zu verwenden. Diese gewährleisten eine einwandfreie Montage, ohne die Lager oder die Außenteile des Getriebes zu beschädigen. Die in Berührung kommenden Passungen und Oberflächen der Wellen sind zu fetten/ölen, um ein Festfressen durch Passungsrost zu vermeiden.
- Bei Lackierung ist darauf zu achten, daß alle Gummitteile und fallweise die in den Entlüftungsdeckeln vorhandenen Bohrungen nicht überlackiert werden.
- Bei Getrieben mit Ölstopfen ist die zum Transport verwendete Verschlusschraube durch die beigelegte Entlüftungsschraube zu ersetzen.
- Der Schmierölstand ist an der Füllstandsanzeige zu überprüfen, sofern vorhanden.
- Der Antrieb ist stufenweise in Betrieb zu nehmen, wobei zunächst mit Teillast angefahren werden sollte.
- Sind unter dem Antrieb Geräteteile oder Materialien angeordnet, die durch geringe Mengen austretenden Öls beschädigt werden könnten, so ist eine geeignete Schutzvorrichtung vorzusehen.

EN INSTALLATION

To install the reduction unit it is necessary to note the following Recommendations:

- The mounting on the machine must be stable to avoid any vibration.
- Please check on the rotation direction of output shaft of reducer before montage to customer machine.
- Check the correct direction of rotation of the storage (4/6 months), if the oil seal is not immersed in the lubricant inside the unit, it is recommended to change it since the rubber could stick to the shaft or may even have lost the elasticity it needs to function properly.
- For a shaft mounting, for reduction units with a hollow output shaft, use the torque arms NRW can supply. If this is not possible, make sure that the constraint is axially free and with such play as to ensure free movement for the reduction unit.
- Whenever possible, protect the gear reduction unit against solar radiation and bad weather.
- Ensure the motor cools correctly by ensuring good passage of air from the fan side.
- In the case of ambient temperatures < -5°C or > +40°C call the Technical Service.
- The various parts (pulleys, gear wheels, couplings, shafts, etc.) must be mounted on the solid or hollow shafts using special threaded holes or other systems that anyhow ensure correct operation without risking damage to the bearings or external parts of the units. Lubricate the surfaces in contact to avoid seizure or oxidation.
- Painting must definitely not go over rubber parts and the holes on the breather plugs, if any.
- For units equipped with oil plugs, replace the closed plug used for shipping with the special breather plug.
- Check the correct level of the lubricant through the indicator, if there is one.
- Starting must take place gradually, without immediately applying the maximum load.
- When there are parts, objects or materials under the motor drive that can be damaged by even limited spillage of oil, special protection should be fitted.

IT INSTALLAZIONE

Per l'installazione del riduttore è consigliabile attenersi alle seguenti indicazioni:

- Il fissaggio sulla macchina deve essere stabile per evitare qualsiasi vibrazione.
- Verificare il corretto senso di rotazione dell'albero di uscita del riduttore prima del montaggio del gruppo sulla macchina.
- In caso di periodi particolarmente lunghi di stoccaggio (4/6 mesi) se l'anello di tenuta non è immerso nel lubrificante contenuto all'interno del gruppo, si consiglia la sua sostituzione in quanto la gomma potrebbe essersi incollata all'albero o addirittura aver perso quelle caratteristiche di elasticità necessarie al corretto funzionamento.
- Nel fissaggio pendolare, per riduttori ad albero di uscita cavo, adottare i bracci di reazione forniti da NRW, se questo non è possibile assicurarsi che il vincolo sia libero assialmente e con giochi tali da garantire la libera oscillazione del riduttore.
- Quando possibile proteggere il riduttore dall'irraggiamento solare ed dalle intemperie.
- Garantire un corretto raffreddamento del motore assicurando un buon passaggio d'aria dallato ventola.
- Nel caso di temperature ambiente < -5°C or > +40°C contattare il servizio Assistenza Tecnica.
- Il montaggio dei vari organi (pulegge, ruote dentate, giunti, alberi, ecc.) sugli alberi pieni o cavi deve essere eseguito utilizzando appositi fori filettati o altri sistemi che comunque garantiscano una corretta operazione senza rischiare il danneggiamento dei cuscinetti o delle parti esterne dei gruppi.
- La verniciatura non deve assolutamente interessare le parti in gomma e i fori esistenti sui tappi di sfiato, quando presenti.
- Per i gruppi provvisti di tappi per olio sostituire il tappo chiuso utilizzato per la spedizione con l'apposito tappo sfidato.
- Controllare il corretto livello del lubrificante tramite, quando prevista, apposita spia.
- La messa in funzione deve avvenire in maniera graduale, evitando l'applicazione immediata del carico massimo.
- Quando sotto alla motorizzazione sono presenti organi, cose o materiali danneggiabili dall'eventuale fuoriuscita, anche limitata, di olio è opportuno prevedere un'apposita protezione.

FR

INSTALLATION

Pour l'installation du réducteur, il faut se conformer aux indications suivantes:

- La fixation sur la machine doit être stable pour éviter toute vibration.
- Avant le montage du groupe sur la machine, vérifier que le sens de rotation de l'arbre de sortie du réducteur soit correct.
- En cas de périodes de stockage particulièrement longues (4/6 mois), si la bague d'étanchéité n'est pas immergée dans le lubrifiant contenu à l'intérieur du groupe, on conseille son remplacement, car le caoutchouc pourrait être collé à l'arbre ou avoir perdu les caractéristiques d'élasticité nécessaires à un fonctionnement correct.
- En cas de fixation endulaire, adopter, pour les réducteurs à arbre de sortie creux, les bras de réaction livrés par NRW; au cas où ceci ne soit pas possible, vérifier que la limitation soit axialement libre et ait des jeux pouvant assurer la libre et ait des jeux pouvant assurer la libre oscillation du réducteur.
- Si possible, protéger le réducteur des rayons du soleil et des intempéries.
- Vérifier que le refroidissement du moteur soit suffisant, en assurant un bon passage d'air du côté ventilateur.
- En cas de températures ambiante $< -5^{\circ}\text{C}$ ou $> +40^{\circ}\text{C}$, contacter le S.c.e techniques.
- Le montage de différents organes (poulies, roues dentées, accouplements, arbres, etc.) sur les arbres pleins ou creux doit être effectué en utilisant les trous filetés ou d'autres systèmes assurant de toute façon une opération correcte, sans risquer d'endommager les roulements ou les parties extérieures des groupes. Lubrifier les surfaces en contact, afin d'éviter le grippage ou l'oxydation.
- La peinture ne doit absolument pas toucher les parties en caoutchouc et, si présents, les trous sur les bouchons d'évent.
- Pour les groupes avec bouchons d'huile, remplacer le bouchon, utilisé lors de l'expédition, par le bouchon d'évent.
- Contrôler, grâce au voyant (si prévu), que le niveau du lubrifiant correspond.
- La mise en marche doit s'effectuer d'une façon graduelle, en évitant l'application immédiate de la charge maximale.
- Si des organes, des choses ou des matériels pouvant être endommagés par l'éventuelle sortie d'huile, même si limitée, sont présents sous la motorisation, il faut prévoir une protection adéquate.

ES

INSTALACIÓN

Para la instalación del reductor, atenerse a las siguientes indicaciones:

- Para evitar las vibraciones, la fijación sobre lamáquina tiene que ser estable.
- Antes del montaje del grupo sobre la máquina, controlar que el sentido de rotación del eje de salida del reductor sea correcto.
- En caso de periodos de almacenamiento muy largos (4/6 meses), si el retén no está sumergido en el lubricante contenido en el grupo, se aconseja su reemplazo porque la goma podría estar pegada al eje o haber perdido las características de elasticidad necesarias para un funcionamiento correcto.
- En la fijación pendular, adoptar, para reductores de eje de salida hueco, los brazos de reacción entregados por NRW; si no es posible, asegurarse que la limitación esté axialmente libre y con juegos que puedan garantizar la libre oscilación del reductor.
- Siempre que sea posible, proteger el reductor contra los rayos del sol y la intemperie.
- Controlar que la refrigeración del motor sea suficiente, asegurando una correcta transferencia de aire del lado ventilador.
- En caso de temperatura ambiente de $< -5^{\circ}\text{C}$ o $> +40^{\circ}\text{C}$, ponerse en contacto con el Servicio técnico.
- El montaje de distintos órganos (poleas, ruedas dentadas, acoplamientos, ejes, etc.) sobre los ejes macho o huecos debe ser efectuado utilizando los agujeros roscados correspondientes u otros sistemas, asegurando una manipulación correcta sin correr el riesgo de dañar los cojinetes o las partes externas de los grupos.
- El barnizado no debe cubrir las partes de goma y los agujeros en los existentes tapones-respiraderos.
- Para los grupos equipados de tapones de aceite, reemplazar el tapón cerrado, utilizado durante el transporte, por el tapón respiradero.
- Controlar, por medio del indicador (si previsto), que el nivel del lubricante corresponda.
- La puesta en marcha se debe producir de manera gradual evitando la aplicación súbita de la carga máxima.
- Si bajo el reductor hay mecanismos, cosas ó materiales que puedan dañarse por una eventual pérdida de aceite, deberá preverse una protección adecuada.

DE **QUERBELASTUNGEN - TECHNISCHE BESCHREIBUNGEN**

Der Wert der zulässigen Querbelastrung (N) wird in den Tabellen über die Leistungen des betreffenden Getriebes aufgeführt und ist die Kraft, die auf die Mittellinie der Wellen unter ungünstigsten Bedingungen wie Anwendungswinkel und Drehrichtung einwirkt.

Die zulässigen Axialbelastungen tragen 1/5 der aufgeführten Querbelastrungen, wenn diese gleichzeitig einwirken.

Die Tabellen über die Abtriebswellen geben den für die Lager bzw. das Gehäuse zulässigen Höchstwert an; dieser Wert darf nie überschritten werden.

Falls die im Katalog aufgeführten Grenzwerte überschritten werden sollen, setzen Sie sich bitte mit unserem Kundendienst in Verbindung und nennen Sie ihm alle Anwendungsdaten wie Belastungsrichtung, Drehrichtung der Welle, Anwendungsart.

Sofort die Anwendung mit einer beiseitigen Einleitung der Querkraft arbeitet, ist die Anwendung hinsichtlich der Einsatzbedingungen zu überprüfen.

Hierzu kontaktieren Sie bitte unser technisches Büro.

Querbelastrungen

Die Querbelastrung (Querkraft) auf der Welle wird durch nachstehende Formel berechnet:

$$FR_{XL} = \frac{2000 \cdot M \cdot fz}{D} \leq FR_1 \text{ o } FR_2$$

FR_{XL} (N)
Resultierende Querkraft
M (Nm)
Wellendrehmoment
D (mm)
Durchmesser des an der Welle montierten Antriebselements
FR (N)
Max. zul. Querkraft (siehe entspr. Tafel)

fz = 1,1 Zahnrad
1,4 Rad für Kette
1,7 Flanschscheibe
2,5 Flachriemenscheibe

Sofort die resultierende Querkraft nicht auf die Mitte der Welle bezogen ist, ist die effektive Kraft durch nachstehende Formel zu berechnen;

$$FR_X = \frac{FR_{1-2} \cdot a}{(b + x)}$$

a, b = siehe Tabellen auf Seite 22
x = Abstand der Querkraft zur Wellenschulter

EN **RADIAL LOADS - TECHNICAL DESCRIPTIONS**

The value of the admissible radial load (N) is given in the tables relating to the performance of the reduction unit at issue. It is related to the load applied on the centre line of the shaft and in the most unfavourable conditions of angle of application and direction of rotation.

The maximum admissible axial loads are 1/5 of the value of the given radial load when applied in combination with the radial load.

The tables relating to the output shafts give the maximum admissible value.

This value must never be exceeded since it relates to the strength of the case.

Particular conditions of radial load higher than the limits of the catalogue may occur. In this case, call our Technical Service and provide details on the application: direction of the load, direction of rotation of the shaft, type of service.

In case of double extension shaft with radial load applied on both ends, the max. admissible radial loads must be defined according to the specific running conditions, in this case call our Technical service.

Radial Loads

The radial load on the shaft is calculated with the following formula:

$$FR_{XL} = \frac{2000 \cdot M \cdot fz}{D} \leq FR_1 \text{ o } FR_2$$

FR_{XL} (N)
Resulting radial load
M (Nm)
Torque on the shaft
D (mm)
Diameter of the transmission member mounted on the shaft
FR (N)
Value of the maximum admitted radial load (see relative tables)

fz = 1,1 gear pinion
1,4 chain wheel
1,7 v-pulley
2,5 flat pulley

When the resulting radial load is not applied on the centre line of the shaft, it is necessary to calculate the effective load with the following formula;

$$FR_X = \frac{FR_{1-2} \cdot a}{(b + x)}$$

a, b = values given in the tables on page 22.
x = distance from the point of application of the load to the shaft shoulder

IT **CARICHI RADIALI - DESCRIZIONI TECNICHE**

Il valore del carico radiale (N) ammissibile viene riportato nelle tabelle relative alle prestazioni del riduttore in esame, ed è relativo al carico applicato sulla mezzeria dell'albero e nelle condizioni più sfavorevoli come angolo di applicazione e senso di rotazione.

I carichi assiali massimi ammissibili sono 1/5 del valore del carico radiale indicato quando sono applicati in combinazione col carico radiale stesso.

Nelle tabelle relative agli alberi di uscita viene indicato il valore massimo ammissibile, questo valore non deve mai essere superato in quanto è relativo alla resistenza della cassa. Possono essere verificate condizioni particolari di carico radiale superiori ai limiti di catalogo, in questo caso contattare il ns. Servizio Tecnico.

Servizio Tecnico e fornire tutti i dati applicativi: direzione del carico, senso di rotazione dell'albero, tipo di servizio.

Nel caso di alberi bisporgenti e cavi in cui è previsto l'applicazione di carichi radiali su entrambe le estremità, i carichi massimi ammissibili sono da definire in funzione delle condizioni di esercizio specifiche, in questo caso contattare il ns. Servizio Tecnico.

Carichi Radiali

Il carico radiale sull'albero si calcola con la seguente formula:

$$FR_{XL} = \frac{2000 \cdot M \cdot fz}{D} \leq FR_1 \text{ o } FR_2$$

FR_{XL} (N)
Carico radiale risultante
M (Nm)
Momento torcente sull'albero
D (mm)
Diametro dell'elemento di trasmissione montato sull'albero
F (N)
Valore di carico radiale massimo ammesso FR₁-FR₂ (ved. tab. relative)

fz = 1,1 Pignone dentato
1,4 Ruota per catena
1,7 Puleggia a gola
2,5 Puleggia piana

Quando il carico radiale risultante non è applicato in mezzeria dell'albero occorre correggere il carico radiale ammissibile FR₁₋₂ con la seguente formula:

$$FR_X = \frac{FR_{1-2} \cdot a}{(b + x)}$$

a, b = Valori riportati nelle tabelle pag. 22.
x = distanza del punto di applicazione del carico da spallamento albero

FR

**CHARGES RADIALES -
DESCRIPTIONS TECHNIQUES**

La valeur de la charge radiale (N) admissible est indiquée dans les tableaux concernant les performances du réducteur ex aminé et correspond à la charge appliquée sur la ligne médiane de l'arbre, dans les conditions les plus défavorables au niveau de l'angle d'application et du sens de rotation.

Les charges axiales maximales admissibles sont 1/5 de la valeur de la charge radiale indiquée, au cas où elles seraient appliquées en combinaison avec la charge radiale même.

Les tableaux concernant les arbres de sortie indiquent la valeur maximale admissible, valeur qui ne doit jamais être dépassée car elle correspond à la résistance de la carcasse.

Des conditions particulières de charges radiales supérieures aux limites de catalogue peuvent être vérifiées; dans ce cas, contacter notre Service Technique en donnant toutes les données d'application: direction de la charge, sens de rotation de l'arbre, type de service.

Dans le cas d'arbre double avec une charge radiale appliquée aux deux extrémités, la charge radiale maximale admissible doit être définie selon les conditions de fonctionnement spécifiques, dans ce cas, contacter notre service technique.

Charges Radiales

La charge radiale sur l'arbre doit être calculée selon la formule suivante:

$$FR_{XL} = \frac{2000 \cdot M \cdot fz}{D} \leq FR1 \text{ o } FR2$$

FR_{XL} (N)

Charge radiale résultante

M (Nm)

Moment de torsion sur l'arbre

D (mm)

Diámetro de l'élément de transmission monté sur l'arbre

FR (N)

Valeur de charge radiale maximum admise (voir tableaux correspondants)

fz = 1,1 pignon denté
1,4 roue pour chaîne
1,7 poulie à gorge
2,5 poulie plate

Quand la charge radiale résultante n'est pas appliquée au milieu de l'arbre, il est nécessaire de corriger la charge radiale admissible FR1-2 avec la formule suivante:

$$FR_X = \frac{FR1-2 \cdot a}{(b + x)}$$

a, b = valeurs indiquées dans les tableaux à page 22.

x = distance entre le point d'application de la charge et l'épaulement de l'arbre

ES

**CARGAS RADIALES -
DESCRIPCIONES TECNICAS**

El valor de carga radial (N) admisible es el indicado en las tablas relacionadas a las prestaciones del reductor examinado y se refiere a la carga aplicada sobre la línea de centro del eje y en las condiciones más desfavorables como ángulo de aplicación y sentido de rotación.

Las cargas axiales máximas admisibles son 1/5 del valor de carga radial indicado, cuando están aplicadas en combinación con la carga radial misma.

En las tablas relacionadas a los ejes de salida se indica el valor máximo admisible; nunca se debe superar este valor, porque se refiere a la resistencia de la carcasa.

Podrían presentarse condiciones particulares de carga radial superiores a los límites de catálogo; en este caso, ponerse en contacto con nuestro Servicio Técnico e indicar todos los datos de la aplicación: dirección de carga, sentido de rotación del eje, tipo de servicio.

En caso de ejes dobles o huecos sobre los que se prevea la aplicación de cargas radiales sobre ambos extremos, las cargas máximas admisibles deben definirse en función de las características de la aplicación, en ese caso contactar a nuestro Servicio Técnico.

Cargas Radiales

La carga radial sobre el eje se calcula con la siguiente fórmula:

$$FR_{XL} = \frac{2000 \cdot M \cdot fz}{D} \leq FR1 \text{ o } FR2$$

FR_{XL} (N)

Carga radial resultante

M (Nm)

Par de torsión sobre el eje

D (mm)

Diámetro del elemento de transmisión montado sobre el eje

FR (N)

Valor de carga radial máximo admitido (ver tablas correspondientes)

fz = 1,1 Piñón dentado
1,4 Piñón de cadena
1,7 Polea para correa trapezoidal
2,5 Polea plana

Cuando carga radial resultante no se aplica sobre el centro del eje de salida, se debe corregir la carga radial admisible FR1-2 mediante la siguiente fórmula:

$$FR_X = \frac{FR1-2 \cdot a}{(b + x)}$$

a, b = valores indicados en las tablas pág. 22.

x = distancia desde el punto de aplicación de la carga hasta la base del eje

DE QUERBELASTUNGEN - TECHNISCHE BESCHREIBUNGEN
FR CHARGES RADIALES - DESCRIPTIONS TECHNIQUES

EN RADIAL LOADS - TECHNICAL DESCRIPTIONS
ES CARGAS RADIALES - DESCRIPCIONES TECNICAS

IT CARICHI RADIALI - DESCRIZIONI TECNICHE

Abtriebswellen

Sofern die radiale Querkraft nicht auf die Mitte der Welle bezogen ist, ist die effektive zulässige Kraft FRX2 durch Formel zu berechnen:

Arbres De Sortie

Quand la charge radiale n'est pas au milieu de l'arbre, il est nécessaire de corriger la charge radiale admissible FRX2 avec la formule suivante:

$$FRX2 = \frac{FR2 \cdot a}{(b+x)} \text{ (N)}$$

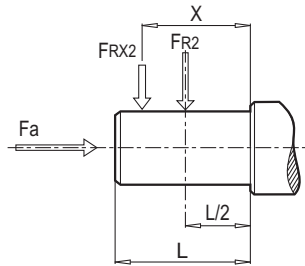

D/M	302-303	352-353	402-403	502-503	602-603
a	125	145	190	225	265
b	96	116	150	175	202
M (FR2 max)	6000	10000	18000	22000	30000
D (FR2 max)	6000	4000	7200	9000	11200

- (*) Die Werte der maximal zulässigen Axialkräfte beziehen sich auf eine Drehrichtung bei verbautem Axiallager (auf Anfrage).
- (*) Maximum axial load values admissible in only one direction with the use of a thrust bearing (on request).
- (*) Valori di carico assiale massimo ammissibile in una sola direzione per versione con cuscinetto reggispira (a richiesta).
- (*) Valeurs de charge axiale maximum admissible dans une seule direction pour la version avec roulements coniques (sur demande).
- (*) Valores de la fuerza axial maxima admissible en un unico sentido con rodamiento axial (bajo demanda).

Die Werte der zulässigen Querbewertungen sind in den Seiten über die Leistungen (FR) aufgeführt.
The values of the admissible radial loads are given on the pages relating to performance. (FR)
Accettabili valori di carico radiale sono dati relativi alle prestazioni pagine. (FR)
Les valeurs des charges radiales admissibles sont indiquées dans les pages concernant les performances (FR)
Los valores de cargas radiales admisibles son indicados en las páginas sobre las prestaciones (FR)

Antriebswellen

Sofern die radiale Querkraft nicht auf die Mitte der Welle bezogen ist, ist die effektive zulässige Kraft FRX1 durch Formel zu berechnen:

Arbres D'entree

Quand la charge radiale n'est pas au milieu de l'arbre, il est nécessaire de corriger la charge radiale admissible FRX1 avec la formule suivante:

$$FRX1 = \frac{FR1 \cdot a}{(b+x)} \text{ (N)}$$

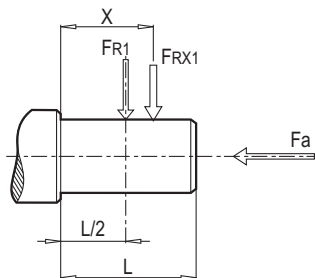

D/M	302-303	352-353	402-403	502-503	602-603
a	105	105	137	137	175
b	80	80	108	108	135
FR1 max	1500	2500	3600	3600	7200

Output Shafts

When the radial load is not on the centre line of the shaft it is necessary to adjust the admissible radial load FRX2 with the following formula:

Ejes De Salida

Si la carga radial resultante no se aplica sobre el centro del eje, corregir la carga radial admisible FRX2 mediante la siguiente fórmula:

Alberi In Uscita

Con carico radiale risultante non in mezziera dell'albero, correggere il carico radiale ammissibile FRX2 con la formula:

Input Shafts

When the radial load is not on the centre line of the shaft it is necessary to adjust the admissible radial load FRX1 with the following formula:

Ejes De Entrada

Si la carga radial resultante no se aplica sobre el centro del eje, corregir la carga radial admisible FRX1 mediante la siguiente fórmula:

Alberi In Entrata

Con carico radiale risultante non in mezziera dell'albero, correggere il carico radiale ammissibile FRX1 con la formula:

DE

TRÄGHEITSMOMENTE

Die angegebenen Werte sind Richtwerte und beziehen sich auf Getriebe mit IEC Eingangsflansch.
Die angegebenen Werte beziehen sich jeweils auf das max. Massenträgheitsmoment.

EN

MOMENTS OF INERTIA

Following values are indicative only and refer to gear reducers fitted with input PAM.
These values refer to maximum moment of inertia.

IT

MOMENTI D'INERZIA

I seguenti valori sono solo indicativi. Sono riferiti a riduttori già predisposti con l'attacco motore PAM.
I valori in tabelle sono riferiti al massimo di quelli calcolati.

FR

MOMENTS D'INERTIE

Les valeurs suivantes sont seulement indicatives et se rapportent à des réducteurs de vitesse équipés avec l'entrée PAM.
Ces valeurs sont relatives au moment d'inertie maximum.

ES

MOMENTOS DE INERCIA

Los valores siguientes son sólo indicativos y se refieren a los reductores con PAM de entrada.
Estos valores están referidos al momento de inercia máximo.

D/M	J*1E-4 [kgm ²]
D/M 302-303	1.4
D/M 352-353	4.1
D/M 402-403	7.1
D/M 502-503	9.2
D/M 602-603	28.4

DE SCHMIERUNG

Bei in der Tafel nicht vorgesehenen Umgebungstemperaturen setzen Sie sich bitte mit unserem Kundendienst in Verbindung.

Bei Temperaturen unter -30°C oder über 60°C werden Dichtringe aus besonderen Elastomeren benötigt.

Bei Betrieb mit Temperaturen unter 0°C ist folgendes zu berücksichtigen:

- 1- Die Motoren müssen für den Betrieb mit der vorgesehene niedrigen Raumtemperatur geeignet sein.
- 2- Die Leistung des Elektromotors muß so ausgelegt werden, daß die höheren benötigten Anlaufdrehmomente aufgebracht werden können.
- 3- Bei Getriebeghäusen aus Guß sind die Stoßbelastungen zu beachten, weil der Guß bei Temperaturen unter -15°C verbröden könnte.
- 4- Bei Betriebsbeginn könnten Schmierungs - probleme infolge der hohen Ölviskosität auftreten, daher ist es sinnvoll, für einige Minuten einen Leerlauf auszuführen.

Nach ca. 10.000 Stunden, bzw. nach 2 Jahren, muss das Öl gewechselt werden. Dieser Zeitraum kann sich durch besondere Betriebsbedingungen und Umwelteinflüsse verkürzen. Antriebe ohne Ölablassschrauben sind lebensdauer geschmiert und benötigen keinen Ölwechsel.

EN LUBRICATION

In cases of ambient temperatures not envisaged in the table, call our Technical Service.

In the case of temperatures under -30°C or over 60°C it is necessary to use oil seals with special properties.

For operating ranges with temperatures under 0°C it is necessary to consider the following:

- 1- The motors need to be suitable for operation at the envisaged ambient temperature.
- 2- The power of the electric motor needs to be adequate for exceeding the higher starting torques required.
- 3- In the case of reduction units with a cast iron case, pay attention to impact loads since cast iron may have problems of fragility at temperatures under -15°C .
- 4- During the early stages of service, problems of lubrication may arise due to the high level of viscosity taken on by the oil and so it is wise to have a few minutes of rotation under no load.

The oil needs to be changed after approximately 10,000 hours/2 years of operations. This period depends on the type of service and the environment where the gear reducer works. For units supplied without oil plugs, lubrication is permanent and so they need no servicing.

IT LUBRIFICAZIONE

Nei casi con temperature ambiente non previste in tabella contattare il ns. Servizio Tecnico.

In caso di temperature inferiori a -30°C o superiori a 60°C occorre utilizzare anelli di tenuta con mescole speciali.

Per i campi di funzionamento con temperature inferiori a 0°C occorre considerare quanto segue:

- 1- I motori devono essere idonei al funzionamento con temperatura ambiente prevista.
- 2- La potenza del motore elettrico deve essere adeguata al superamento delle maggiori coppie di avviamento richieste.
- 3- Nel caso di riduttori con cassa in ghisa prestare attenzione ai carichi d'urto in quanto la ghisa può presentare problemi di fragilità a temperature inferiori a -15°C .
- 4- Durante le prime fasi di servizio possono insorgere problemi di lubrificazione cause l'elevata viscosità che assume l'olio e quindi è opportuno procedere ad alcuni minuti di rotazione a "vuoto".

Il cambio olio deve essere eseguito dopo circa 10.000 ore/2 anni di funzionamento, questoperiodo è in funzione del tipo di servizio e dell'ambiente in cui opera il riduttore. Per i gruppi forniti senzatappi per l'olio la lubrificazione si intende permanente e quindi non hanno necessità di alcuna manutenzione.

FR LUBRIFICATION

En cas de températures ambiantes non prévues dans le tableau, contacter notre Service Technique.

En cas de température au-dessous de -30°C ou au-dessus de 60°C , il faut utiliser des bagues d'étanchéité avec mélanges spéciaux.

Pour les champs de fonctionnement avec température au-dessus de 0°C , il faut considérer ce qui suit:

- 1- Les moteurs doivent être aptes au fonctionnement à la température ambiante prévue.
- 2- La puissance du moteur électrique doit être au dépassement e la plupart des couples de démarrage demandés.
- 3- En cas de réducteurs avec carcasse en fonte, faire attention aux charges de choc, car la fonte peut présenter des problèmes de fragilité à températures au-dessous de -15°C .
- 4- Lors des premières phases de service, des problèmes de lubrification dus à la viscosité élevée, que l'huile assume, pourraient se vérifier; il faut donc procéder à une rotation "à vide" de quelques minutes.

L'huile doit être changée après 10,000 heures environ/2 ans de fonctionnement, cette période dépend du type de service et de l'environnement dans lequel fonctionne le réducteur.

Pour les produits livrés sans bouchons d'huile, la lubrification est permanente et ils ne nécessitent aucun entretien.

ES LUBRICACIÓN

En caso de temperaturas ambiente no previstas en la tabla, ponerse en contacto con nuestro Servicio técnico.

En caso de temperaturas inferiores a -30°C o superiores a 60°C , es necesario utilizar anillos de retén con mezclas especiales. Para los campos de funcionamiento con temperaturas inferiores a 0°C , es necesario cumplir con lo que sigue:

- 1- Los motores tienen que ser idóneos al funcionamiento con la temperatura ambiente prevista.
- 2- La potencia del motor eléctrico debe adecuarse para superar los mayores pares de arranque pedidos.
- 3- En caso de reductores con carcasa de fundición, cuidado con las cargas de choque porque la fundición puede presentar problemas de fragilidad con temperaturas inferiores a los -15°C .
- 4- Durante las primeras fases de servicio podrían surgir problemas de lubricación debidos a la elevada viscosidad del aceite y es por lo tanto oportuno efectuar una rotación en "vacío" por algunos minutos.

El cambio de aceite debe efectuarse aproximadamente cada 10.000 horas/2 años funcionamiento, este periodo va en función del tipo de servicio y del ambiente en que opera el reductor.

Para los grupos suministrados sin tapones de aceite la lubricación es permanente y no requieren mantenimiento.

DE SCHMIERUNG

EN LUBRICATION

IT LUBRIFICAZIONE

FR LUBRIFICATION

ES LUBRICACIÓN

Mineralöl / Mineral Oil / Olio Minerale / Huile Minérale / Aceite Mineral							
	T°C ISO SAE...	ENI	SHELL	ESSO	MOBIL	CASTROL	BP
D/M 302...602 D/M 303...603	(-5) / (+40) ISO VG220	BLASIA 220	OMALA OIL220	SPARTAN EP220	MOBILGEAR 630	ALPHA MAX 220	ENERGOL GR-XP220
	(-15) / (+25) ISO VG150	BLASIA 150	OMALA OIL150	SPARTAN EP150	MOBILGEAR 629	ALPHA MAX 150	ENERGOL GR-XP150

- Spezifische Schmierstoffangabe erfragen Sie bei NRW Drive Technologies.
- Specifications of lubricants recommended by NRW Drive Technologies..
- Specifiche dei lubrificanti consigliati da NRW Drive Technologies.
- Especificaciones de lubricante aconsejados por NRW Drive Technologies.
- Spécification des lubrifiants suivant NRW Drive Technologies.

- Für die Ölmengen siehe die Seiten. (Seite 26)
- For the quantity of oil, please refer to the pages relating. (page 26)
- Per le quantità di olio si rimanda alle pagine relative. (pagina 26)
- Pour les quantités d'huile, voir pages concernant. (page 26)
- Para las cantidades de aceite, ver a las páginas. (página 26)

Spezialschmierstoffe / Special lubricants / Lubrificanti speciali / Lubrifiants spéciaux / Lubricantes especiales				
		*T°C	Synthetisches Öl / Synthetic oil / Olio sintetico / Huile synthétique / Aceite sintetico	Minralöl / Mineral oil / Olio minerale / Huile minérale / Aceite mineral
Öle für niedrige Temperaturen Oils for low temperature Oli per basse temperature Huiles pour basse température Aceites para bajas temperaturas	ENI	(-25) ÷ (+30)	BLASIA 150 S (ISO VG150)	-
	KLUBER	(-35) ÷ (+20)	KLUBERSYNTH GH 6-80 (ISO VG68)	-
	MOBIL	(-40) ÷ (+10)	SCH 624 (ISO VG32)	-
	ENI	(-40) ÷ (+10)	-	ROTRAATF
Öle für niedrige Temperaturen - Food-Sektor Oils for low temperature - Food sector Oli per basse temperature - Settore alimentare Huiles pour basse température - Secteur de l'alimentation Aceites para bajas temperaturas - Sector alimentario	KLUBER	(-40) ÷ (+10)	-	SUMMIT HYSYN FG32
Öle für hohe Temperaturen / Oils for high temperature / Oli per alte temperature / Huiles pour haute température / Aceites de alta temperatura	KLUBER	(-10) ÷ (+50)	KLUBERSYNTH GH 6-460 (ISO VG460)	-
	KLUBER	(-10) ÷ (+70)	KLUBERSYNTH GH 6-680 (ISO VG680)	-
	SHELL	(-10) ÷ (+70)	-	OMALA OIL 680
Öle für hohe Temperaturen - Food-Sektor Oils for high temperature - Food sector Oli per alte temperature - Settore alimentare Huiles pour haute température - Secteur de l'alimentation Aceites de alta temperatura - Sector alimentario /	KLUBER	(-10) ÷ (+50)	4UH1-6 460 (ISO VG460)	-
Food-Sektor / Food sector / Settore alimentare / Secteur de l'alimentation / Sector alimentario	KLUBER	(-15) ÷ (+40)	4UH1- 320N (ISO VG460)	-

Falls spezielles Öl verwendet werden soll kontaktieren sie bitte unseren Kundendienst
If 'special' lubricant is required please contact for Technical Assistance
Per l'utilizzo di lubrificanti speciali, contattare l'assistenza tecnica
Si un Lubrifiant spécial est demandé, merci de contacter notre service technique.
Para el uso de lubricantes especiales contactar con la asistencia técnica

* Betriebsumgebungstemperatur
* Working ambient temperature
* Temperatura ambiente di funzionamento
* Température ambiante de fonctionnement
* Temperatura ambiente de funcionamiento

DE SCHMIERUNG

- Für die Getriebe der Serie D/M ist die Einbaulage anzugeben.
 - D/M 302 - 303 - 352 - 353, werden mit Schmiermittel befüllt geliefert. Die Getriebe bedürfen keinerlei Wartung und sind werkseitig mit einem Verschlussstopfen versehen.
 - Die Getriebe der Serie D/M in den Baugrößen 402 - 403 - 502 - 503 - 602 - 603 werden werkseitig mit Schmieröl, sowie Ölschaugläsern ausgeliefert.
 Die erforderliche Ölmenge und die Positionen der Ölschaugläsern entsprechen der werkseitig vorgeschlagenen Position.
 Vor der Inbetriebnahme sind die Verschlussstopfen, durch entsprechende Entlüftungsventile, gemäß der Einbaulage, auszutauschen.
 Die angegebenen Ölmenigen sind Richtwerte. Diesemüssen je nach Einbaulage, über Ölschaugläser, Ölstandsbohrungen oder Ölmesststäbe (je nach Type) regelmässig überprüft werden.
 Ölstandsunterschiede können aus verschiedenen Einbaulagen bei Applikationen resultieren. Nach jeder Montage, sind alle Ölstände sind zwingend zu prüfen und gegebenenfalls anzupassen.

EN LUBRICATION

- For the reduction units D/M series it is always necessary to specify the mounting position.
 - D/M 302 - 303 - 352 - 353, are supplied complete with lubricant, have no oil plugs and need no maintenance
 - The gear reducer D/M series sizes 402 - 403 - 502 - 503 - 602 - 603 are supplied complete with lubricant and are fitted with oil plugs to suit any mounting position included in the catalogue.
 It is recommended, after installation, to replace the closed plug used for transportation with the supplied breather plug. Lubricant quantities are only indicative, For correct filling always refer to the sight glass or the dipstick, when this is supplied.
 Any oil level differences can be caused by constructive tolerances but also on the mounting position or the assembly scheme of the customer Therefore it is very important for the customer to check oil level and if necessary to add the necessary quantity.

IT LUBRIFICAZIONE

- Per i riduttori serie D/M occorre sempre specificare la posizione di piazzamento prevista.
 - D/M 302 - 303 - 352 - 353, vengono forniti completi di lubrificante sono sprovvisti dei tappi olio e non hanno necessità di alcuna manutenzione
 - I riduttori serie D/M nelle grandezze 402 - 403 - 502 - 503 - 602 - 603 vengono forniti completi di lubrificante a dei tappi olio necessari a garantire la corretta lubrificazione nella posizione di piazzamento richiesta.
 Si raccomanda, effettuata l'installazione, di sostituire il tappo chiuso utilizzato per il trasporto con il tappo di sfiato fornito a corredo.
 Le quantità di olio in tabella sono solo indicative e per il corretto riempimento si dovrà fare riferimento al tappo o all'astina di livello, se presente
 Eventuali scostamenti di livello possono dipendere da tolleranze costruttive ma anche dal piazzamento del riduttore o dal piano di montaggio presso cliente. Per tale motivo è opportuno che il cliente verifichi e, se necessario, ristabilisca il livello a riduttore installato.

FR LUBRIFICATION

- Pour les réducteurs série D/M il faut toujours spécifier la position de montage.
 - D/M 302 - 303 - 352 - 353, sont fournis avec lubrifiant et sans bouchons et ne nécessitent, donc, aucun entretien
 - Les réducteurs série D/M pour les grandeurs 402 - 403 - 502 - 503 - 602 - 603 sont fournis avec tous les bouchons nécessaires pour garantir toutes les positions de montage prévues au catalogue.
 On recommande, après l'installation, de changer le bouchon livré pour le transport contre celui fourni avec trou d'évent. Les quantités d'huile indiquées en tableau sont seulement indicatives et pour un remplissage correct il faut faire référence au bouchon de niveau ou à la jauge à huile, si présents.
 Toutes les différences de niveau d'huile peuvent être causées par des tolérances de constructions, ou par la position de montage, ou le schéma d'assemblage du client. Par conséquent il est très important que le client vérifie le niveau d'huile et au besoin ajoute la quantité nécessaire.

ES LUBRICACIÓN

- Para los reductores serie D/M es necesario especificar siempre la posición de montaje.
 - D/M 302 - 303 - 352 - 353, se suministran con lubricante, no disponen de tapón aceite y no necesitan ningún mantenimiento .
 - Los reductores serie D/M en los tamaños 402 - 403 - 502 - 503 - 602 - 603 se suministran con lubricante y disponen de tapones para todas las posiciones de montaje previstas en el catálogo.
 Es necesario, una vez instalado el reductor en la máquina, sustituir el tapón cerrado, utilizado durante el transporte, por el tapón respiradero que se adjunta.
 Las cantidades de lubricante en la tabla son indicativas y para un correcto llenado hay que tomar de referencia el centra del visor o del asta de nivel si están instaladas.
 Eventuales diferencias del nivel de aceite pueden depender de tolerancias constructivas pero también de la posición de montaje o del esquema de montaje del cliente. Por tanto es muy importante que el cliente compruebe el nivel de aceite y si es necesario agregue la cantidad adecuada.

D/M	302-303	352-353	402-403	502-503	602-603
M1-M3	2.2	2.9	5.4	7.9	15.6
M2	2.6	3.2	6.8	10.0	19.0
M4	3.0	3.7	7.0	10.5	20.0
M5	2.0	2.4	5.7	8.6	15.5
M6	1.6	2.1	3.9	5.7	11.5

- Ölmenge (Liter) ~
- Quantity of oil in litres ~
- Quantità olio in litri ~
- Quantité d'huile en litres ~
- Cantidad de aceite en litros ~

DE EINBAULAGE
FR POS. DE MONTAGE

EN MOUNTING POSITIONS
ES POS. DE MONTAJE

IT PIAZZAMENTO

M...

- 302 - 303
- 352 - 353
- 402 - 403
- 502 - 503
- 602 - 603

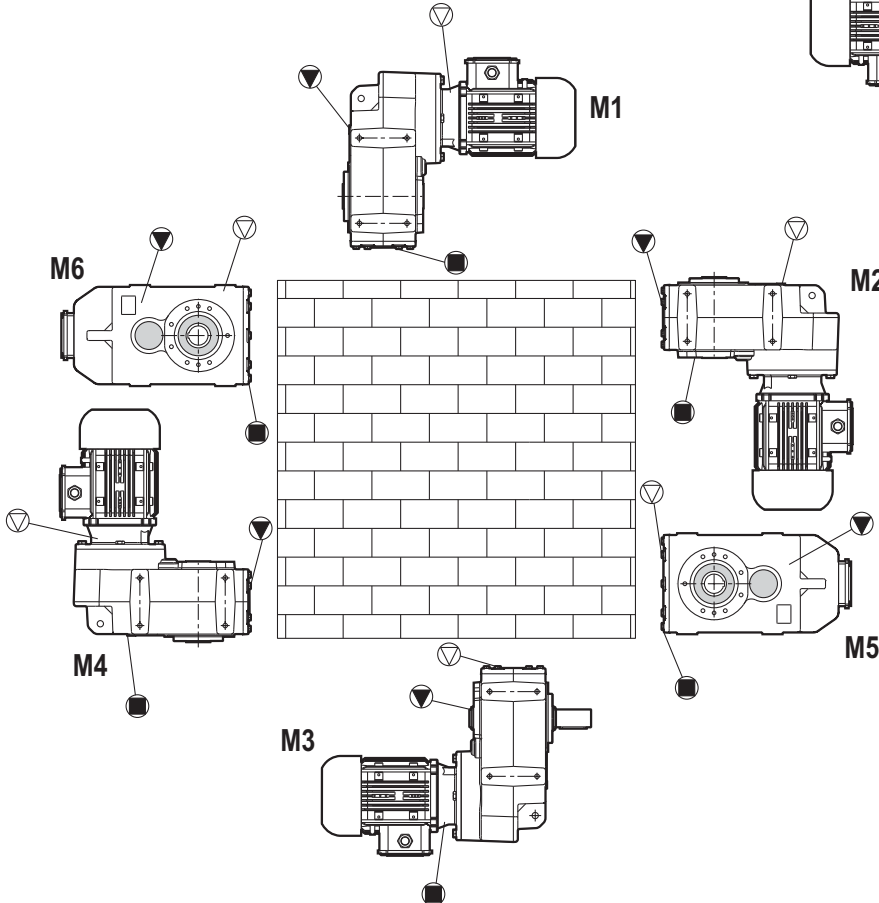
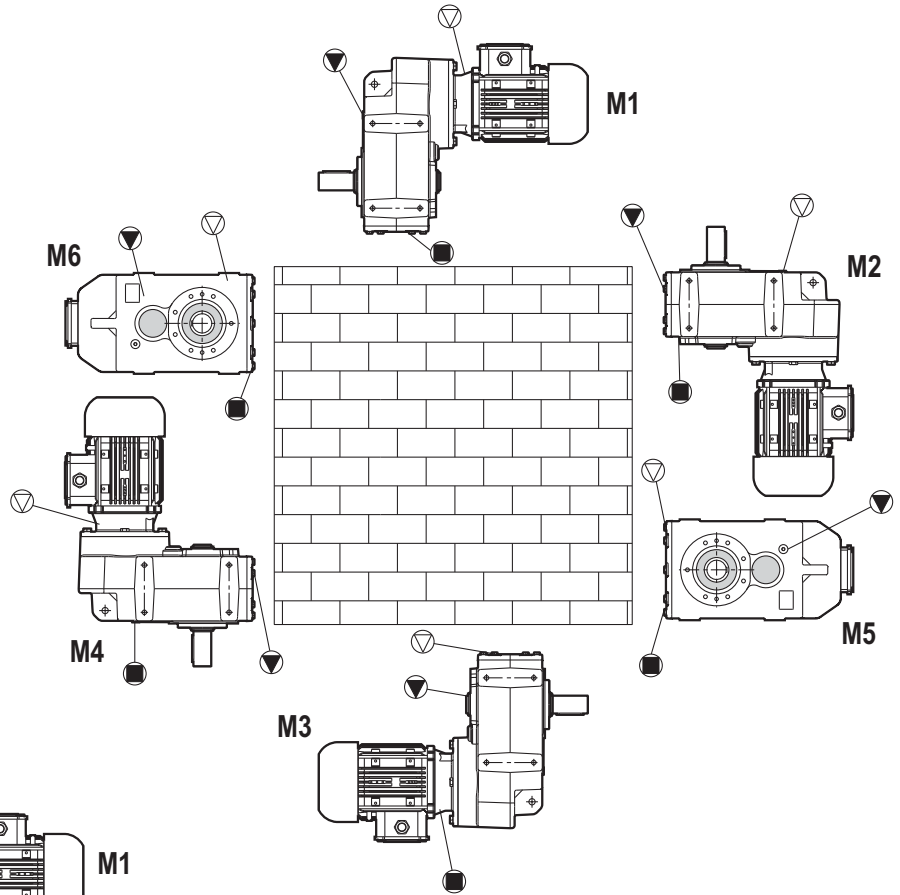

D...

- 302 - 303
- 352 - 353
- 402 - 403
- 502 - 503
- 602 - 603

⊖ Entlüftung / Vent plug / Tappo di sfatio /
Évent / Ventilación

● Öblass / Drain plug / Tappo di scarico dell'olio /
Vidange d'huile / Vaciado de aceite

⊖ Ölstand / Oil level / Tappo di livello dell'olio /
Niveau d'huile / Nivel de aceite

DE EINBAULAGE

- Für die vertikalen einbaulagen siehe seite 10-11.
- Falls nicht anders angegeben, sind M1 die standard einbaulagen.
- Für nicht angegebene einbaulagen setzen sie sich bitte mit unserem kundendienst in verbindung.

EN MOUNTING POSITIONS

- For vertical positions, check with pages 10-11.
- Unless specified otherwise, the standard positions are M1.
- For positions not envisaged, it is necessary to call our Technical Service.

IT PIAZZAMENTO

- Per le posizioni di piazzamento verticali verificare quanto detto a pag. 10-11.
- Se non diversamente specificato le posizioni standard sono M1.
- Per le posizioni di piazzamento non previste occorre rivolgersi al ns. Servizio tecnico.

FR POS. DE MONTAGE

- Pour les positions de montage verticales, voir pages 10 et 11.
- Si non spécifié, les positions standard sont M1.
- Pour les positions de montage non prévues, contacter notre S.ce technique.

ES POS. DE MONTAJE

- Para las posiciones de montaje verticales, ver las páginas 10-11.
- Si non se especifica el contrario, las posiciones estándar son M1.
- Para las posiciones demontajenoprevistas, es necesario ponerse en contacto con nuestro Servicio técnico.

**D302...602
D303...603**

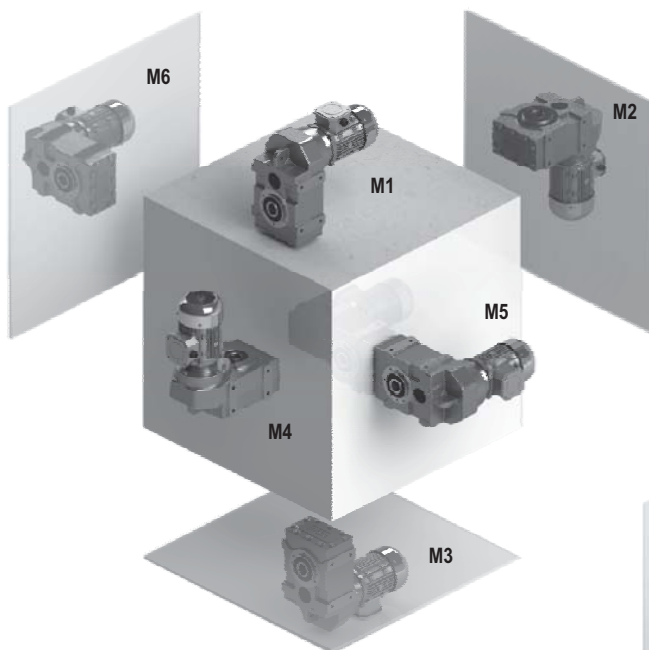

**M302...602
M303...603**

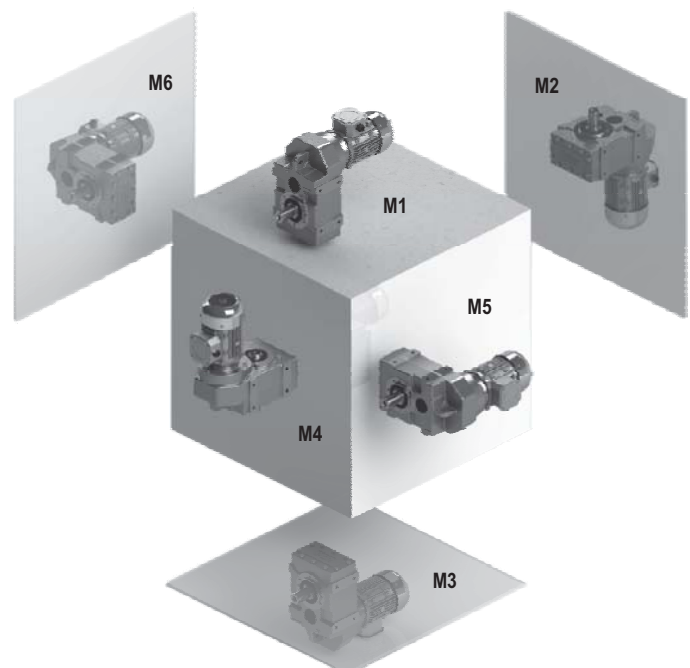

DE

EINBAULAGE

Klemmenkastenlage

- Im Falle von Sonderanforderungen ist bei Auftragserteilung die Lage des Klemmenkastens gemäß dem Schema genau anzugeben.
- Sofern nichts Gegenteiliges angegeben, wird der schneckengetriebemotor mit klemmkastenlage 1 geliefert.

EN

MOUNTING POSITIONS

Position Of Terminal Box

- In the case of specific requirements, when ordering, specify the position of the terminal box as shown in the diagram.
- Unless otherwise specified, the gear reducer is supplied with terminal box in position 1.

IT

PIAZZAMENTO

Posizione Morsetteria

- Nel caso di particolari esigenze specificare in fase di ordine la posizione della morsetteria come da schema.
- Se non diversamente specificato, il gruppo viene fornito con morsetteria in pos.1.

FR

POS. DE MONTAGE

Position Du Bornier

- En cas d'exigences particulières, spécifier, lors de la commande, la position du bornier comme d'après le schéma.
- Sauf indications contraires, le réducteur est fourni avec boîte à borne en position 1.

ES

POS. DE MONTAJE

Posición Caja De Bornes

- En caso de exigencias particulares, detallar en el pedido, la posición de la caja de bornes según el esquema.
- Si no esta diferentemente especificado, el motorreductor se monta con la caja de bornes en posición 1.

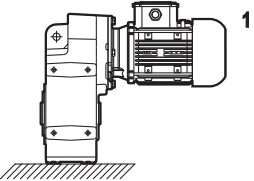
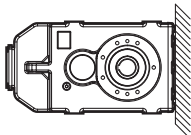
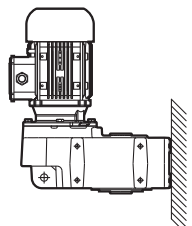
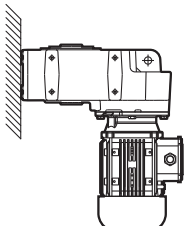
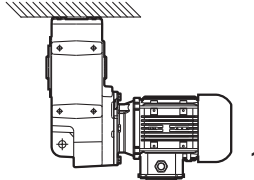
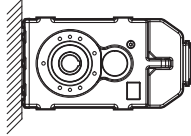
M1	M6	M4	M2
			
M3	M5		
			

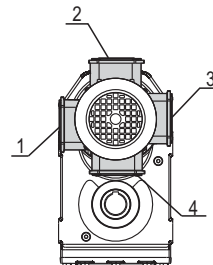
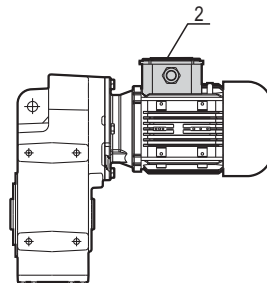

DE MODULARES BAUKASTENSYSTEM

EN MODULARITY

IT MODULARITÀ

FR MODULARITÉ

ES MODULARIDAD

D/M...PAM

- Ausführungen zum anbau von PAM - Motoren.
- Fitted for motor coupling version (PAM).
- Versione con predisposizione per attacco motore PAM.
- Version avec prédisposition pour moteur PAM.
- Versión motorreductor (PAM).

D/M...W

- Ausführungen mit antriebsvollwelle.
- Input shaft versions.
- Versioni con albero maschio in ingresso.
- Version avec arbre en entrée.
- Versión con eje macho de entrada.

D/M...90L/4A

- Ausführungen mit kompakt elektro motoren.
- Compact electric motor versions.
- Versioni con motore elettrico compatto.
- Version avec moteur électrique compact.
- Versión motorreductor compacto.

D/M...IEC

- Die verbindung motor getriebe erfolgt über kupplung.
- Fitted for motor mounting with flexible coupling.
- Predisposto per attacco motore con giunto.
- Prédisposé pour montage moteur avec joint.
- Predisposto para montaje motor con acoplamiento.

D...

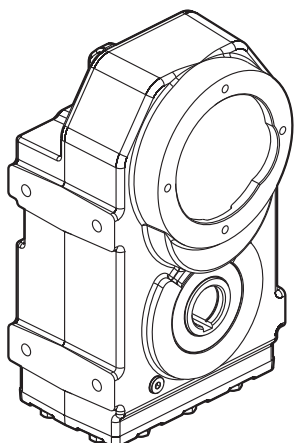

M...

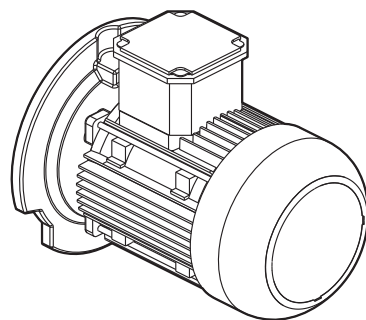
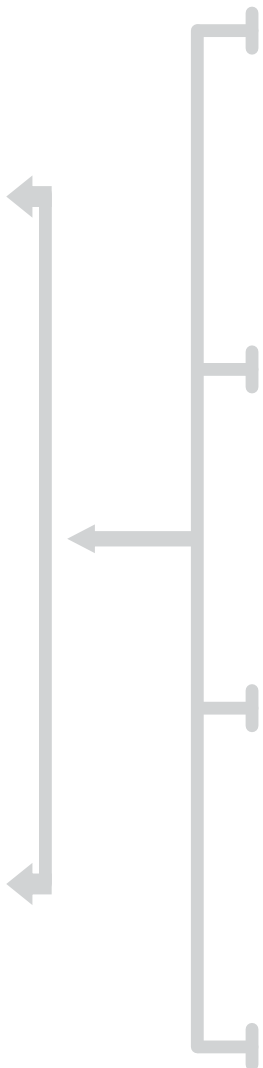
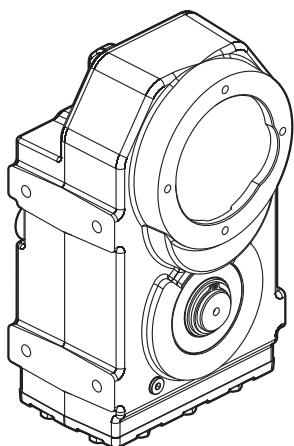

MOTOR

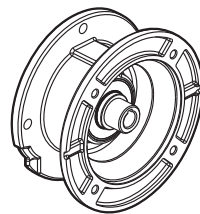

PAM

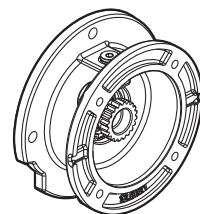

IEC

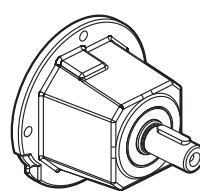

W

DE PRODUKTE
FR PRODUITS

EN PRODUCTS
ES PRODUCTOS

IT PRODOTTI

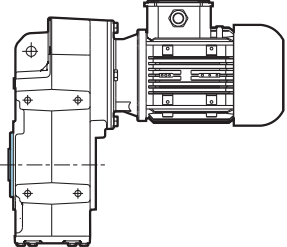
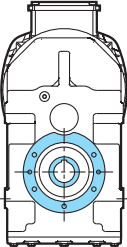
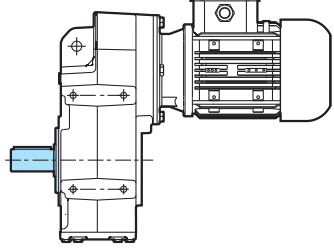
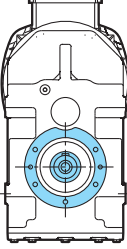
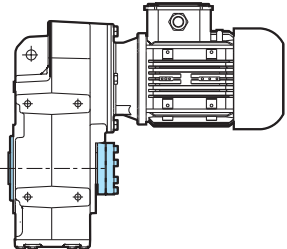
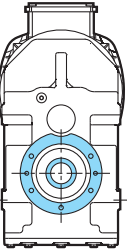
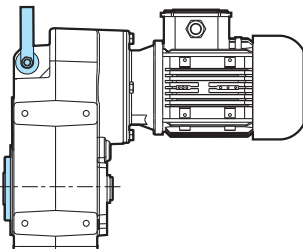
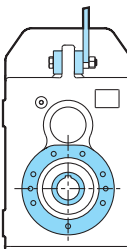
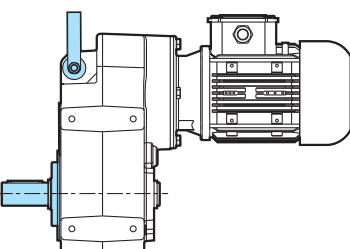
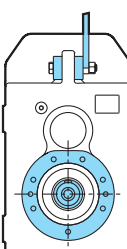
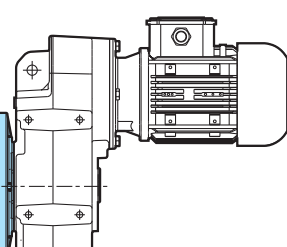
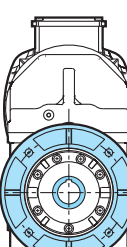
		<p>D ... B14</p> <p>Hohlwelle / B14 Flanschbefestigung Hollow shaft / B14 Flange mounting Albero cavo / B14 Fissaggio flangia Arbre creux / B14 Fixation à bride Eje hueco / B14 Fijación por brida</p>
		<p>M ... B14</p> <p>Vollwelle / B14 Flanschbefestigung Solid shaft / B14 Flange mounting Albero pieno / B14 Fissaggio flangia Arbre en / B14 Fixation à bride Eje macizo / B14 Fijación por brida</p>
		<p>D ... KS</p> <p>Hohlwelle / Schrumpfscheibe. Hollow shaft / Shrink disc shaft. Albero cavo / Albero calettatore. Arbre creux / Arbre avec frette Eje hueco / Eje hueco con aro de apriete</p>
		<p>D ... LT</p> <p>Hohlwelle / Gummipuffer Hollow shaft / Rubber buffer Albero cavo / Paracolpi in gomma Arbre creux / Tampon de caoutchouc Eje hueco / Tape de goma</p>
		<p>M ... LT</p> <p>Vollwelle / Gummipuffer Solid shaft / Rubber buffer Albero pieno / Paracolpi in gomma Arbre en / Tampon de caoutchouc Eje macizo / Tape de goma</p>
		<p>D ... B5</p> <p>Hohlwelle / Flansch B5 Hollow shaft / Flange B5 Albero cavo / Flangia B5 Arbre creux / Bride B5 Eje hueco / Brida B5</p>

DE PRODUKTE

EN PRODUCTS

IT PRODOTTI

FR PRODUITS

ES PRODUCTOS

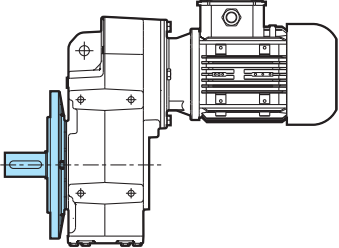
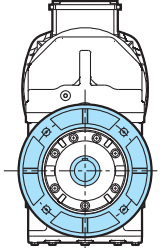
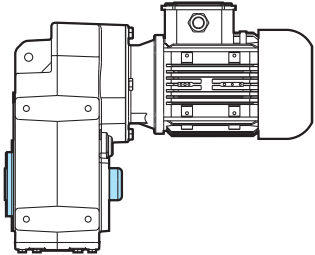
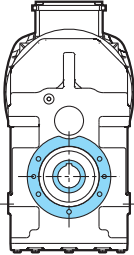
		<p>M ... B5</p> <p>Vollwelle / Flansch B5 Solid shaft / Flange B5 Albero pieno / Flangia B5 Arbre en / Bride B5 Eje macizo / Brida B5</p>
		<p>D ... Ç</p> <p>Hohlwelle / Befestigungsbauteile Hollow shaft / Fixing element Albero cavo / Elementi de fissaggio Arbre creux / Éléments de fixation Eje hueco / Elementos ds fijación</p>

DE BEISPIEL BESTELLBESCHREIBUNG

EN EXAMPLE FOR ORDERING

IT ESEMPIO DI ORDINAZIONE

FR EXEMPLE DE COMMANDE

ES EJEMPLO ORDEN DE COMPRA

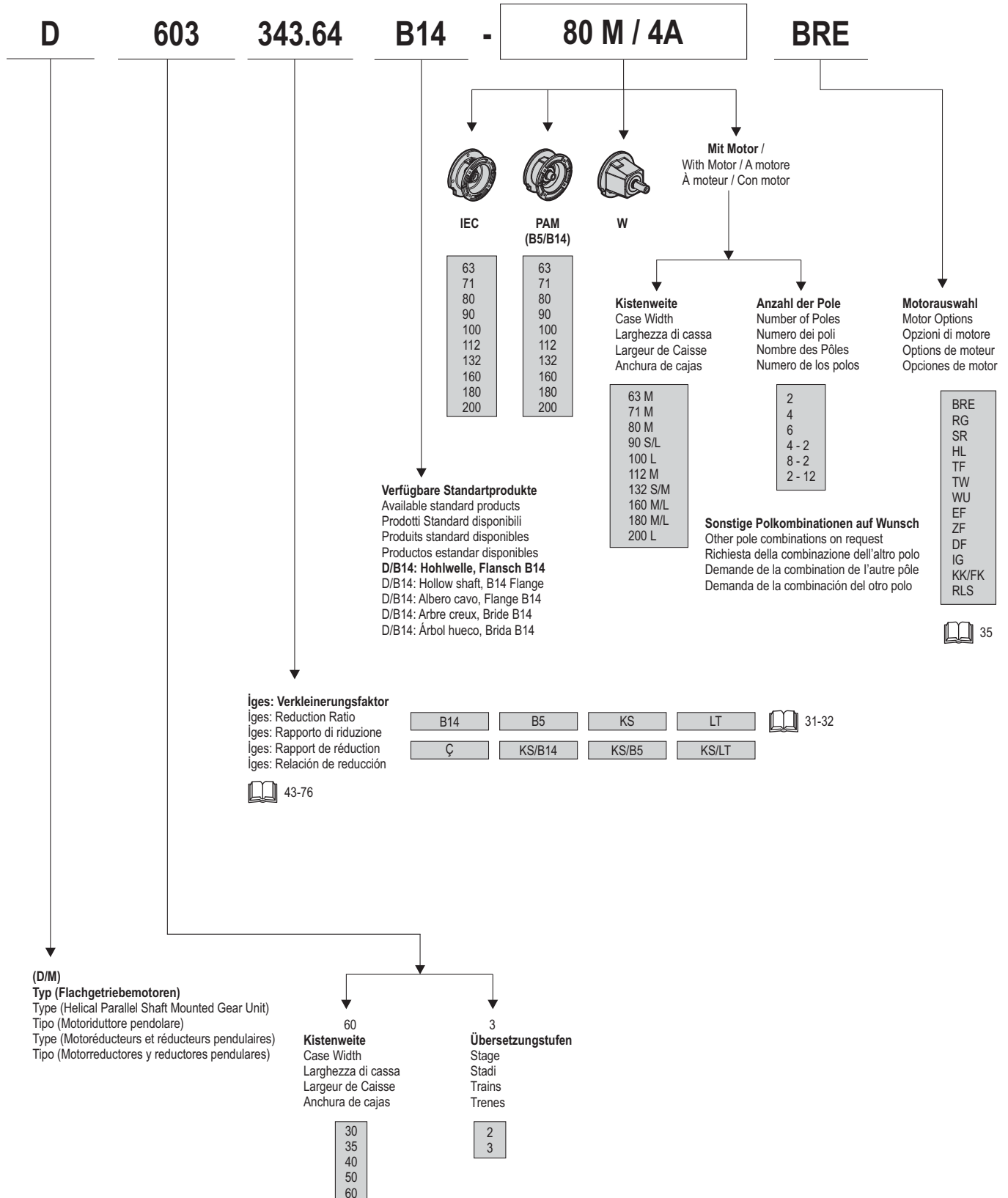

DE	BEZEICHNUNG	EN	DESIGNATION	IT	DESIGNAZIONE
FR	DÉSIGNATION	ES	DESIGNACIÓN		

D / M

D / M	Flanch getriebemotoren und Flanchgetriebe Parallel shaft mounted gear unit Motoriduttori e riduttori pendolari Motorréducteurs et réducteurs pendulaires Motorreductores y reductores pendulares		
302	Baugröße 30 - 2 Übersetzungsstufen - Ausführung in Grauguss Size 30, 2 reduction stages, cast iron series Grandezza 30, 2 stadi di riduzione, serie in ghisa Grandeur 30, 2 trains d'engrenages, série en fonte Tamaño 30, 2 trenes de engranajes, gama de fundición		
FA - FB - FC	Abtriebsflansch Output flange Flangia di uscita Bride de sortie Brida de salida		
29.9	Übersetzungsverhältnis Reduction ratio Rapporto di riduzione Rapport de réduction Relación de reducción		
M1	Einbaulage Mounting position Posizione di piazzamento Position de montage Posición de montaje		
Abmessungen antriebsseitig / Input dimensions / Dimensioni di entrata / Dimensions d'entrée / Dimensiones de entrada			
PAM	Für motoranbau vorbereitet Fitted for motor coupling Predisposto per attacco motore Prédisposé pour montage moteur standard Predispuesto para montaje motor		
112	Motorflansch - Durchmesser Motor flange diameter Diametro flangia motore Diamètre bride moteur Diámetro brida motor	28	Motorwellen - Durchmesser Drive - shaft diameter Diametro albero motore Diamètre arbre moteur Diámetro eje motor
Abmessungen abtriebsseitig / Output dimensions / Dimensioni di uscita / Dimensions de sortie / Dimensiones de salida			
250	Durchmesser Abtriebsflansch Output flange diameter Diametro flangia uscita Diamètre de la bride de sortie Diámetro brida de salida	40	Durchmesser abtriebswelle Output shaft diameter Diametro albero uscita Diamètre de l'arbre de sortie Diámetro eje de salida

DE	NOMENKLATUR	EN	NOMENCLATURE	IT	NOMENCLATURA
FR	NOMENCLATURE	ES	NOMENCLATURA		

<p>Eingabeoptionen Input Options Opzioni di ingresso Options d'entrée Opciones de entrada</p>	<p>W = Ausführungen mit antriebsvollwelle / Input shaft versions / Versioni con albero maschio in ingresso / Version avec arbre en entrée / Versión con eje macho de entrada.</p> <p>IEC = Die Verbindung Motor Getriebe erfolgt über Kupplung / Fitted for motor mounting with flexible coupling / Predisposto per attacco motore con giunto / Prédisposé pour montage moteur avec joint / Predispuosto para montaje motor con acoplamiento</p> <p>T = Turbokupplung / Turbo coupling / Turbogiunto / Coupleur hydraulique / Turboacoplador</p>
<p>Motor Motor Motore Moteur Motor</p>	<p>Drehstrommotor Motorgröße 63 - 200 / Three phase motor Motor size 63 - 200 / Motori trifase, Grandezze 63 - 200 / Motore thriphasé, taille moteur 63 - 200 / Motores trifásicos, Tamaño de carcasas 63 - 200</p>
<p>Anzahl der Pole Number of Poles Numero dei poli Nombre des Pôles Numero de los polos</p>	<p>2 = 2 Pole / 2 Poles / 2 Poli / 2 Pôles / 2 Polos</p> <p>4 = 4 Pole / 4 Poles / 4 Poli / 4 Pôles / 4 Polos</p> <p>6 = 6 Pole / 6 Poles / 6 Poli / 6 Pôles / 6 Polos</p> <p>Sonstige Polkombinationen auf Wunsch / Other pole combinations on request / Richiesta della combinazione dell'altro polo / Demande de la combination de l'autre pôle / Demanda de la combinación del otro polo</p>
<p>Motorauswahl Motor Options Opzioni di motore Options de moteur Opciones de motor</p>	<p>BRE = Mit Bremsen / With brake / Freno / avec frein / Freno</p> <p>EF = Separate Lüfter, einphasig / Separate fan, single phase / Ventilatore separato, monofase / Ventilateur séparé, une phase / Ventilador por separado de una sola fase</p> <p>ZF = Separate Lüfter, Doppel-phase / Separate fan, double phase / Ventilatore separato, doppia fase / Ventilateur séparé, double-phase / Ventilador por separado, de doble fase</p> <p>DF = Separate Lüfter, drei-phase / Separate fan, three phase / Ventilatore separato, trifase / Ventilateur séparé, trois phases / Ventilador por separado, tres de fase</p> <p>IG = Mit Encoder / With encoder / Con encoder / Avec codeur / Con codificador</p> <p>KK/FK = Kupplungs / With clutches / Con frizioni / Embrayage / Embrague</p> <p>SR = Bremsstaub - Nachweis / Brake dust - proof / Freno a prova di polvere / Frein à l'épreuve de la poussière / De frenos a prueba de polvo</p> <p>TF = Thermistor / Thermistor / Termistore / Thermistance / Termistor</p> <p>RG = Bremse auf Korrosion geschützt / Brake corrosion - protected / Freno resistente alla corrosione / Frein à la corrosion protégées / Freno protegida contra la corrosión</p> <p>WU = Soft-start-rotor / Soft start rotor / Soft start rotore / Démarrage en douceur du rotor / Soft desde el rotor</p> <p>B = Rücklaufsperr / Backstop / Bloccato contro il ritorno / Verrouillé contre le retour / Bloqueado en contra de devolución</p> <p>TW = Eine wärmeempfindliche / Thermal trip / Un sensible al calore / A sensible à la chaleur / Un sensible al calor</p> <p>HL = Handbremsmotoren / Brake motor with hand release / Motore autofrenante mano / Moteur de frein à main / motores freno manuales</p>

DE ZUBEHÖR
FR ACCESSOIRES

EN ACCESSORIES
ES ACCESORIOS

IT ACCESSORI

**2 Übersetzungsstufen / 2 Stages /
2 Stadi / 2 Trains / 2 Trenes**

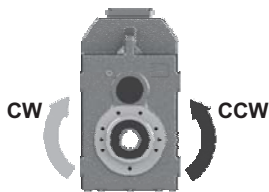

Ausgangseite / Output side /
Lato uscita / Côté sortie /
Lado de salida

**3 Übersetzungsstufen / 3 Stages /
3 Stadi / 3 Trains / 3 Trenes**

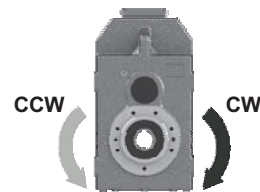

Ausgangseite / Output side /
Lato uscita / Côté sortie /
Lado de salida

Rücklaufsperr

Das Getriebe ist mit Rücklaufsperr auf der Antriebswelle erhältlich. Die Rücklaufsperr verhindert die Rotation in die falsche Drehrichtung. Entsprechend der Größe ist sie im Antriebsflansch oder dem Motor integriert. Wichtig ist die Angabe der gewünschten abtriebsdrehrichtung.

Backstop Device

The gear reducer can be supplied with backstop device on input shaft. Backstop device allows output shaft rotation in only one sense of direction; according to the size, it is available in the input flange or in the motor with the same dimensions. It is important to specify the required sense of direction on the order.

Dispositivo Antiretro

Il riduttore può essere fornito munito di dispositivo antiretro sull'asse veloce. L'antiretro permette la rotazione degli alberi in un solo senso, a seconda della grandezza è disponibile nella flangia PAM oppure nel motore, senza ingombri aggiuntivi. E' molto importante, in fase di ordine, specificare il senso di rotazione richiesto.

Système Antidévireur

Le réducteur de vitesse peut être fourni avec le dispositif anti-retour sur l'axe d'entrée. Le dispositif anti retour permet la rotation des arbres de sortie dans un seul sens; selon la taille, il est disponible dans la bride d'entrée ou dans le moteur avec les mêmes dimensions. Il est important de spécifier le sens de la direction demandé sur l'ordre.

Dispositivo Antirretorno

El reductor puede suministrarse con un dispositivo antirretorno en el eje veloz. El antirretorno permite la rotación de los ejes en un solo sentido, según el tamaño está disponible en la brida PAM o en el motor, sin incremento de dimensiones. Es muy importante especificar en el pedido el sentido de rotación requerido.

Motor	063	071	080	090	100 - 112	132	160	180	200	225	250	280
Größe Size Grandezza Taille Tamaño	140x11	160x14	200x19	200x24	250x28	300x38	350x42	350x48	400x55	450x60	550x65	550x75
302		B5/B14	B5/B14	B5/B14	B5/B14							
303	B5/B14	B5/B14	B5/B14	B5/B14								
352		B5/B14	B5/B14	B5/B14	B5/B14							
353		B5/B14	B5/B14	B5/B14								
402			B5/B14	B5/B14	B5/B14	B5/B14						
403		B5/B14	B5/B14	B5/B14	B5/B14							
502			B5/B14	B5/B14	B5/B14	B5/B14	B5					
503		B5/B14	B5/B14	B5/B14	B5/B14							
602			B5/B14	B5/B14	B5/B14	B5/B14	B5	B5	B5			
603			B5/B14	B5/B14	B5/B14	B5/B14						

DE ZUBEHÖR

EN ACCESSORIES

IT ACCESSORI

FR ACCESSOIRES

ES ACCESORIOS

Abtriebswellen / Low Speed Shafts / Alberi Lenti / Arbres Pv / Ejes Lentos

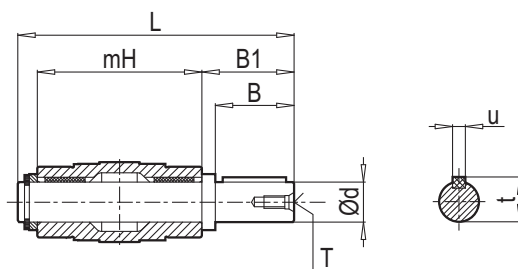

M...

	Ød h6	B	B1	mH	L	T	u	t
352-353	35	58	62	140	210.5	M12	10	38
402-403	40	80	84.25	180	273	M16	12	43
502-503	50	100	105	210	325	M16	14	53.5
602-603	60	120	125	240	375	M20	18	64

Gummipuffer / Rubber Buffer / Paracolpi In Gomma / Tampon De Caoutchouc / Tape De Goma

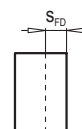
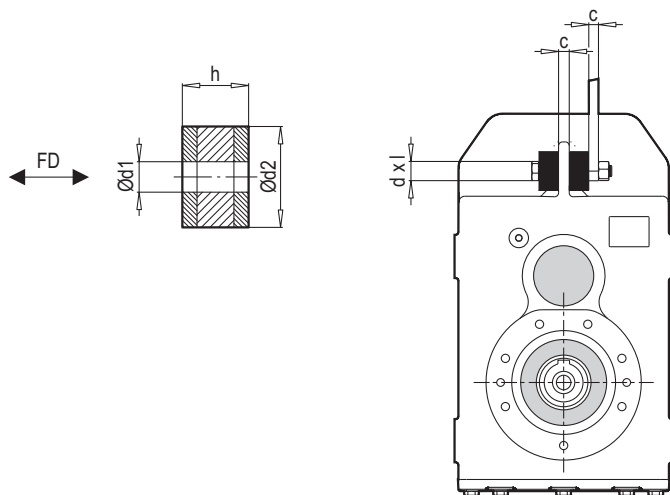

S_{FD} : Federweg eines Gummipuffers.
 S_{FD} : Shows that width of stretch for one rubber buffer.
 S_{FD} : Allungamento di un gommino
 S_{FD} : Allongement d'un butée en caoutchouc
 S_{FD} : Allungamento di un gommino

D/M...LT

	Ød1	Ød2	h	c	d x l	FD [kN]	S _{FD} [mm]
D/M 302 - 303 LT	12.60	40	15	15	M12x80	2.65	1.8
D/M 352 - 353 LT	12.60	40	15	15	M12x80	2.65	1.8
D/M 402 - 403 LT	12.60	40	15	20	M12x90	2.65	1.8
D/M 502 - 503 LT	21.60	60	30	20	M20x140	7.40	7.3
D/M 602 - 603 LT	21.60	60	30	26	M20x150	8.50	8.4

DE ZUBEHÖR
FR ACCESSOIRES

EN ACCESSORIES
ES ACCESORIOS

IT ACCESSORI

Schrumpfscheibe / Shrink Disc / Calettatore / Frette D'accouplement / Aro De Apriete

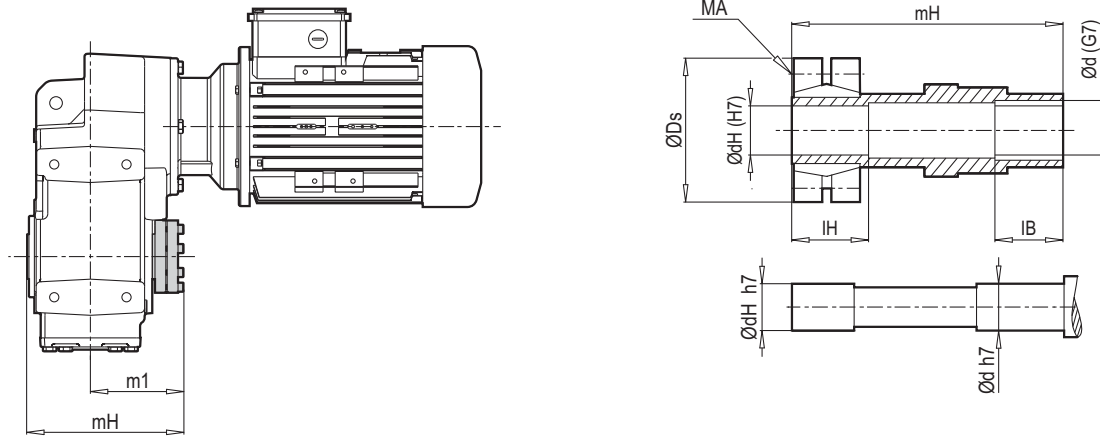

	ØdH	Ød	mH	m1	IH	IB	ØDs	MA 12.9 (Nm)
302-303	30	31	152	92	35	35	74	15
352-353	35	36	173	103	35	40	80	15
402-403	40	41	217	127	40	50	100	15
502-503	50	51	248	143	40	55	115	15
602-603	60	61	282	157	50	60	145	40

Wellenabdeckung / Protection Cover / Coperchio Di Protezione / Couverture De Protection / Tapa De Protección

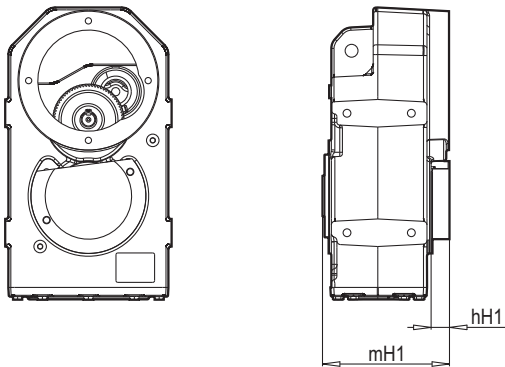

	mH1	hH1
302-303	145	23
352-353	169	30
402-403	209	30
502-503	240	33
602-603	275	40

Cover Der Schrumpfscheibe / Cover Of Shrink Disc / Copertina Di Calettatore / Couverture De Frette De Serrage / Portada Del Anillo De Contracción

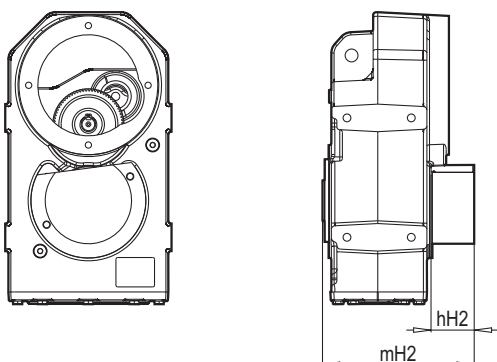

	mH2	hH2
302-303	157	35
352-353	179	40
402-403	222	43
502-503	252	45
602-603	287	52

DE ZUBEHÖR

EN ACCESSORIES

IT ACCESSORI

FR ACCESSOIRES

ES ACCESORIOS

Masse Des Befestigungsbauteils / Dimensions Of Fixing Element / Dimensioni Degli Elementi Di Fissaggio / Dimensions Des Élément De Fixation / Dimensionos De Los Elementos De Fijación

Typ / Type / Tipo / Type / Tipo	1 L	2	3	4	5	6		7		8 d x mH	9		
						d2	s	d3	s3		a	D	
302 - 303	96	A10	l 30 x 1.5	M12	M10 X 45	29.9	3	29.9	12	M12	30 x 120	20	40
352 - 353	110	A12	l 35 x 1.5	M12	M12 X 55	34.9	3	34.9	16	M16	35 x 140	24.5	45
402 - 403	148	A16	l 40 x 2.0	M16	M16 X 70	39.9	4	39.9	16	M16	40 x 180	25	55
502 - 503	170	A16	l 50 x 2.5	M20	M16 X 70	49.9	4	49.9	20	M20	50 x 210	26	65
602 - 603	195	A20	l 60 x 3.0	M24	M20 X 90	59.9	5	59.9	24	M24	60 x 240	31	75

Die auf der Tafel aufgeführten Zahlen werden auf Seite 40-41 erläutert

The numbers which are specified at table are explained on Page 40-41

I numeri che si trovano nella tabella sono espressi sulla pagina 40-41

Les numéros qui se trouvent dans le tableau sont expliqués sur la page 40-41

Los numeros que se halan en la tabla son expresados sobre la pagina 40-41

DE ZUBEHÖR

EN ACCESSORIES

IT ACCESSORI

Befestigungsbauteile

Dies wird für wellenbefestigte Ausführungen verwendet und ist bei der Bestellung anzugeben, da bestimmte Anwendungsvoraussetzungen vorliegen.

Anwendungsbedingungen:

- Die Mittenbohrung muss angemessen bearbeitet sein DIN 332/2.
- Feste Motorwelle kann entweder mit einer Wellenachsel (II) oder ohne Wellenachsel (I) montiert werden.
- Feste Motorwelle ohne Wellenachsel wird anhand Halterungsring (A) montiert.
- Fest Motorwelle mit Wellenachsel wird ohne Abstandhalter montiert.

Fixing Elements

This is used for shaft mounted designs and it should be specified when ordering because there are some requirements for use.

Using conditions:

- Centre bore must be machined appropriately DIN 332/2.
- Solid shaft could be mounted either with a shaft shoulder (II) or without shaft shoulder (I)
- Solid shaft which is without shaft shoulder is mounted with using retainin ring (A)
- Solid shaft which is with shaft shoulder is mounted with using spacer

Elementi De Fissaggio

Questo é utilizzato per il disegno di ingranaggi montati. Deve essere indicato quando se lo ordina in quanto esistono le esigenze per l'utilizzo.

Condizioni di utilizzo

- La perforazione centrale deve essere adeguatamente macchinata DIN332/2
- L'albero sporgente deve essere montato sia con spallamento dell'albero (II) che senza spallamento dell'albero (I)
- L'albero sporgente senza spallamento dell'albero é montato utilizzando la ghiera di fermo (A)
- L'albero sportenge con spallamento dell'albero é montato utilizzando la ghiera distanziatrice

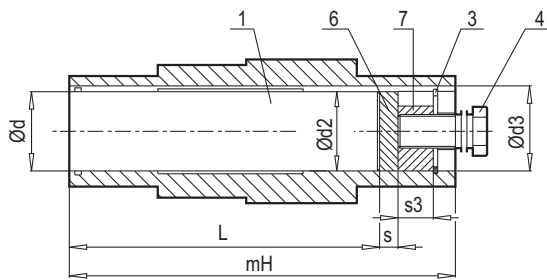
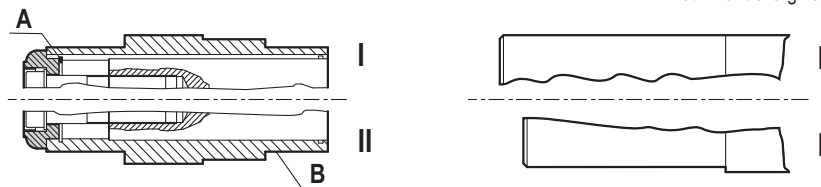

DEMONTAGE / DISASSEMBLY / SMONTAGGIO

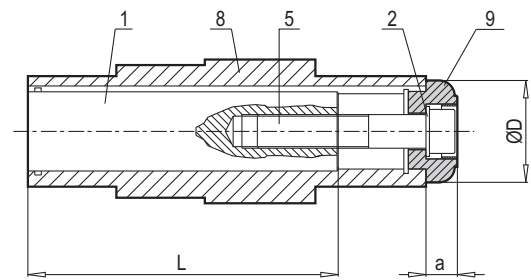

MONTAGE / ASSEMBLY / MONTAGGIO

L-max. länge der Kundenwelle

L= maximum length of the solid shaft

L= Lunghezza massima dell'albero sporgente

- 1) Kunden - Welle
- 2) Federring DIN 127
- 3) * Sicherungsring DIN 472
- 4) * Abdrückschraube
- 5) Zylinderschraube DIN 912
- 6) * Druckscheibe
- 7) * Abdrückmutter
- 8) Hohlwelle
- 9) Scheibe

*Vorschlag, gehört nicht zum Lieferumfang

- 1) Customer's shaft
- 2) Washer DIN 127
- 3) * Circlip DIN 472
- 4) * Jacking screw
- 5) Socket head screw DIN 912
- 6) * Thrust washer
- 7) * Jacking nut
- 8) Hollow shaft
- 9) Disc

*Star signs are shown this item are not provided by NRW

- 1) l'albero del cliente
- 2) Rondella DIN 127
- 3) * Anello di sicurezza DIN 472
- 4) * Vite di alzare
- 5) Vite a testa esagonale DIN 912
- 6) * Rondella reggispira
- 7) * Dado di alzare
- 8) Albero cavo
- 9) Disco

* Gli articoli segnati con la stella non sono forniti da NRW

DEMONTAGE:

- 1) Lösen der Zyl.-Schraube (5)
- 2) Abnehmen der Scheibe (9)
- 3) Druckscheibe (6) einlegen
- 4) Abdrückmutter (7) einsetzen
- 5) Sicherungsring (3)
- 6) Durch Einschrauben der Abdrückschraube (4) Kund. Welle aus der Hohlwelle lösen.

VORAUSETZUNG:

Die Kund. - welle muß mit einer Zentr. Bohrg. DIN 332/2 versehen sein. Die kund. Welle darf max. "L" überschreiten, sonst ist di Verwendung der Abdrückelemente (pos. 5,6,7) nicht möglich.

MONTAGE:

- 1) Kunden-Welle in die Hohlwelle (pos.8) einführen
- 2) Scheibe (pos.9) in die Hohlwelle einsetzen
- 3) Scheibe mittels Zyl. schr (pos.2) und Federring (pos.5) befestigen.

Die aufgeführten maße gelten für Kegelradgetriebe- Typ W, Typ IEC und Kegelradtriebmotoren

DISASSEMBLING:

- 1) Loosen the socket head screw (5)
- 2) Remove disc (9)
- 3) Immerse thrust washer (6)
- 4) Tuck jacking nut (7)
- 5) Mount circlip (3)
- 6) Remove solid shaft from hollow shaft with using jacking screw (4)

REQUIREMENTS:

Solid shaft which is connected to the hollow shaft, must have machined with a centre bore according to DIN 332/2. Consider that 'Lmax'length is important for jacking not using solid shaft's length must not greater than 'Lmax'.

ASSEMBLING:

- 1) Immerse customer shaft to the hollow shaft (8)
- 2) Mount disc to the hollow shaft (9)
- 3) Fasten disc and washer (2) by tightening socket head screw (5)

Dimensions which are shown above of this page are used for all type of helical - bevel gear units.
(Type W, IEC adapter and helical - bevel geared motor.)

SMONTAGGIO

- 1) Allentare la vite a testa esagonale (5)
- 2) Rimuovere il disco (9)
- 3) Immergere la rondelle reggispira (6)
- 4) Introdurre il dado di martinetto (3)
- 5) Montare l'anello di sicurezza (3)
- 6) Rimuovere l'albero sporgente dall'albero cavo utilizzando la vite di astrazione

ESIGENZE

L'albero sporgente connesso all'albero cavo deve essere macchinato con la perforazione centrale secondo DIN 332/2. Considerare che la lunghezza "Lmax" è importante per alzare. La lunghezza dell'albero sporgente non deve essere più grande della "Lmax".

MONTAGGIO

- 1) Immergere l'albero del cliente nell'albero cavo (8)
- 2) Montare il disco all'albero cavo (9)
- 3) Fissare il disco e la rondella (2) stringendo la vite a testa esagonale (5)

Le dimensioni sopracitate su questa pagina non si utilizzano per ogni tipo di ingranaggi elicoidalismussatura.
(Tipo W,IEC adattore ed elicoidale reductor conico)

FR

ACCESSOIRES

ES

ACCESORIOS

Éléments De Fixation

Ceci est utilisé pour le dessin d'engrenages montés II doit être indiqué lorsque l'on commande parce qu'il y a des exigences pour l'utilisation

Conditions d'utilisation

- Le forage central doit être machiné de façon appropriée DIN 332/2
- L'arbre plein doit être monté soit avec l'épaulement de l'arbre (II) soit sans l'épaulement de l'arbre
- L'arbre plein sans l'épaulement de l'arbre est monté en utilisant la bague d'arrêt (A)
- L'arbre plein avec l'épaulement de l'arbre est monté en utilisant la bague distancieuse

Elementos De Fijación

Este se utiliza para el diseño de engranajes montados. Debe indicarse cuando se pide por que existen los requisitos para el uso

Condiciones de uso

- La perforación central debe ser apropiadamente maquinada DIN332/2
- El eje macizo debe montarse con el soporte del eje (II) o sin soporte del eje (I)
- El eje macizo sin soporte del eje se monta utilizando el anillo de retención (A)
- El eje macizo con el soporte del eje se monta utilizando el anillo distanciador

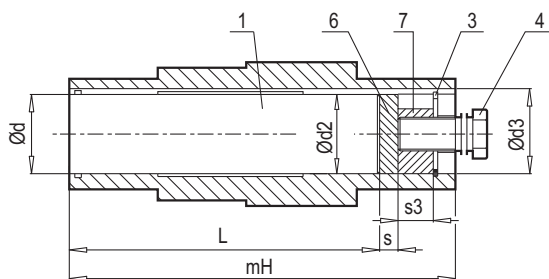
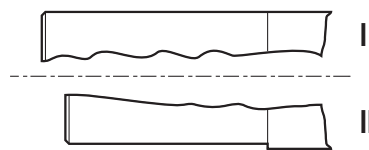
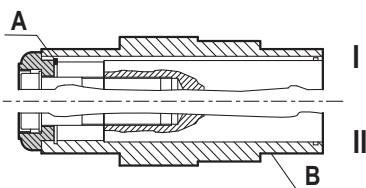

DISASSEMBLING / DESMONTAJE

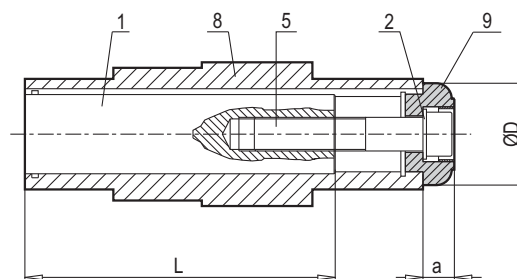

MONTAGE / MONTAJE

L= Longueur max. de l'arbre à entraîner
L= Longitud máxima del eje macizo

- 1) Arbre à entraîner
- 2) Rondelle à ressort DIN 127
- 3) * Circlip DIN 472
- 4) * Vis de démontage
- 5) Vis à tête cylindrique DIN 912
- 6) * Rondelle de pression
- 7) * Ecrou de démontage
- 8) Arbre creux
- 9) rondelle

* Ne font pas partie de la livraison, fournis en supplément

- 1) El eje del cliente
- 2) Arandela DIN 127
- 3) * Anillo de seguridad DIN 472
- 4) * Tornillo extracción
- 5) Tornillo con cabezal hexagonal DIN 912
- 6) * Arandela de empuje
- 7) * Tuerca de levantamiento
- 8) Eje hueco
- 9) Disco

* Los artículos señalados con la estrella no son suministrados por NRW.

DISASSEMBLING:

- 1) Dévisser la vis à tête cylindrique (pos.5)
- 2) Démontez la rondelle (pos.9)
- 3) Mettre en place la rondelle de pression (pos.6)
- 4) Mettre en place l'écrou de démontage (pos.7)
- 5) Mettre en place le circlip (pos.3)
- 6) En vissant la vis de démontage (pos.4) sortir l'arbre à entraîner de l'arbre creux.

DESMONTAJE

- 1) Aflojar el tornillo con cabezal hexagonal (5)
- 2) Quitar el disco (9)
- 3) Sumergir la arandela de empuje (6)
- 4) Introducir la tuerca de levantamiento (7)
- 5) Montar el anillo de seguridad (3)
- 6) Quitar el eje macizo desde el eje hueco utilizando el tornillo de extracción (4)

CONDITION:

L'arbre à entraîner doit être pourvu d'un alésage de centrage DIN 332/2.

L'arbre à entraîner ne doit pas dépasser la cote "L" sinon l'utilisation des éléments de démontage (pos.5,6,7) devient impossible.

REQUISITOS

El eje macizo conectado el eje hueco debe ser maquinado con la perforación central según DIN332/2. Considerar que la longitud "Lmax" es importante para levantar. La longitud del eje macizo debe ser más grande que "Lmax".

MONTAGE:

- 1) Introduire l'arbre à entraîner (pos.8) dans l'arbre creux.
- 2) Placer la rondelle (pos.9) dans l'arbre creux.
- 3) Fixer la rondelle avec la vis à tête cylindrique (pos.2) et la rondelle à ressort (pos.5)

Toutes les dimensions indiquées sont valables pour les réducteurs à couple conique en exécution W et IEC, et pour les motoréducteurs à couple conique.

MONTAJE

- 1) Sumergir el eje del cliente en el eje hueco (8)
- 2) Montar el disco al eje hueco (9)
- 3) Fijar el disco y la arandela (2) apretando el tornillo con cabezal hexagonal (5)

Las dimensiones arriba enunciadas en esta pagina no se utilizan para cada tipo de engranajes helicoidales-reductores conicos (Tipo W, IEC adaptor y helicoidale reductor conino)



**Auswahltabellen der
Getriebemotoren**

Selection Tables of
Gearedmotors

Tabelle di selezione dei
motoriduttori

Tables de Gearedmotors de
sélection

Tablas de selección de
gearedmotors

D/M

**D 302 ... 602
D 303 ... 603**

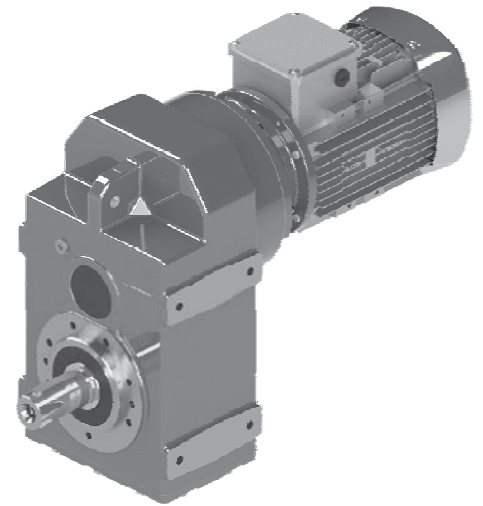

**M 302 ... 602
M 303 ... 603**

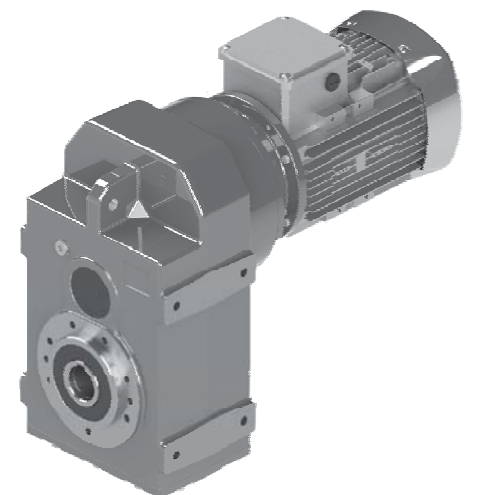

DE TECHNISCHE BESCHREIBUNGEN

EN TECHNICAL DESCRIPTIONS

IT DESCRIZIONI TECNICHE

FR DESCRIPTIONS TECHNIQUES

ES DESCRIPCIONES TECNICAS

Mitteilung über Leistungstafeln für Getriebemotor

Notify about performance tables for Geared motor
 Notificare sulle tabelle di performance per i motoriduttori
 Aviser sur les tableaux de performance pour le motoréducteur
 Notificar sobre la tabla de performance para los motoreductores.

0.37 kW → **Potenza motore riduttore**
 Gear unit motor power
 Potencia del motor del reductor
 Réducteur puissance du moteur
 Getriebe Motorleistung

Motornennleistung
 Rated motor power
 Potenza nominale del motore
 Puissance nominale du moteur
 Potencia nominal del motor

Factor de servicio
 Service factor
 Fattore di servizio
 Facteur de service
 Servicefaktor

Untersetzungsverhältnis
 Reduction ratio
 Rapporto di riduzione
 Rapport de réduction
 Relación de reducción

P ₁ [kW]	n ₂ [Min ⁻¹]	M ₂ [Nm]	f _B	i _{ges}	F _{R2} (M) [kN]	F _{R2} (D,KS) [kN]	Typ / Type / Tipo / Type / Tipo	Kg ~	mm
0.37	18.8	180	1.9	73.89	6.0	6.0	D 302 - 71M/4B M 302 - 71M/4B	26	76
	23.7	143	2.4	58.73	6.0	6.0			
	26.2	129	2.7	53.04	6.0	6.0			
	29.0	117	3.0	47.91	6.0	6.0			
	32.1	106	3.3	43.27	6.0	6.0			
	34.3	99	3.5	40.53	6.0	6.0			
	37.5	91	3.6	37.09	6.0	6.0			
	42.0	81	3.7	33.07	6.0	6.0			
	45.6	74	3.9	30.46	6.0	6.0			



Abtriebsdrehzahl
 Output speed
 Vitesse de sortie
 Velocità di uscita
 Velocidad de salida



Abtriebsdrehmoment
 Output torque
 Coppia di uscita
 Par de salida
 Couple de sortie



Zulässige Radialkraft
 Permissible radial force
 Force radiale admissible
 Fuerza radial admisible
 Forza radiale ammessa



Getriebe Motortyp
 Gear unit motor type
 Réducteur type de moteur
 Reductor tipo de motor
 Riduttore tipo di motore



Zeichenblatt
 Drawing page
 La page de dessin
 Página de dibujo
 Zeichenblatt



P ₁ [kW]	n ₂ [Min ⁻¹]	M ₂ [Nm]	f _B	i _{ges}	F _{R2} (M) [kN]	F _{R2} (D,KS) [kN]	Typ / Type / Tipo / Type / Tipo	 Kg	 mm
0.09	2.8	297	1.2	314.13	6.0	6.0	D 303 - 63M/6 M 303 - 63M/6	26	78
	3.4	242	1.5	256.27	6.0	6.0			
	4.0	205	1.8	217.41	6.0	6.0			
	4.4	187	2.0	198.40	6.0	6.0			
	4.9	167	2.2	177.36	6.0	6.0			
	6.3	130	2.8	137.31	6.0	6.0			
	7.4	111	3.3	117.10	6.0	6.0			
0.12	4.3	248	1.4	314.13	6.0	6.0	D 303 - 63M/4A M 303 - 63M/4A	25	78
	5.3	202	1.7	256.27	6.0	6.0			
	6.3	172	2.0	217.41	6.0	6.0			
	6.9	157	2.2	198.40	6.0	6.0			
	7.7	140	2.5	177.36	6.0	6.0			
	9.9	108	3.2	137.31	6.0	6.0			
	11.7	92	3.8	117.10	6.0	6.0			
	2.8	395	0.9	314.13	6.0	6.0	D 303 - 63M/6B M 303 - 63M/6B	25	78
	3.4	323	1.1	256.27	6.0	6.0			
	4.0	274	1.3	217.41	6.0	6.0			
	4.4	250	1.5	198.40	6.0	6.0			
	4.9	223	1.6	177.36	6.0	6.0			
	6.3	173	2.1	137.31	6.0	6.0			
	7.4	147	2.5	117.10	6.0	6.0			
9.1	120	3.1	95.53	6.0	6.0				
0.15	3.5	387	0.9	256.27	6.0	6.0	D 303 - 63M/6C M 303 - 63M/6C	26	78
	4.1	329	1.1	217.41	6.0	6.0			
	4.5	300	1.2	198.40	6.0	6.0			
	5.1	268	1.4	177.36	6.0	6.0			
	6.6	208	1.8	137.31	6.0	6.0			
	7.7	177	2.1	117.10	6.0	6.0			
	9.4	144	2.5	95.53	6.0	6.0			
	12.2	112	3.3	73.96	6.0	6.0			
	0.18	12.2	137	2.7	73.89	6.0			
15.3		109	3.4	58.73	6.0	6.0			
17.0		98	3.7	53.04	6.0	6.0			
8.9		175	1.5	314.13	6.0	6.0	D 303 - 63M/2A M 303 - 63M/2A	23	78
10.9		143	1.9	256.27	6.0	6.0			
12.9		121	2.2	217.41	6.0	6.0			
14.1		111	2.4	198.40	6.0	6.0			
15.8		99	2.7	177.36	6.0	6.0			
20.4		77	3.5	137.31	6.0	6.0			
4.4		368	1.0	314.13	6.0	6.0	D 303 - 63M/4B M 303 - 63M/4B	23	78
5.4		300	1.2	256.27	6.0	6.0			
6.3		255	1.4	217.41	6.0	6.0			
7.0		232	1.5	198.40	6.0	6.0			
7.8		208	1.7	177.36	6.0	6.0			
10.1		161	2.2	137.31	6.0	6.0			
11.8		137	2.6	117.10	6.0	6.0			
14.4		112	3.1	95.53	6.0	6.0			
4.0		410	0.9	217.41	6.0	6.0	D 303 - 71M/6A M 303 - 71M/6A	27	78
4.4		375	1.0	198.40	6.0	6.0			
4.9		335	1.1	177.36	6.0	6.0			
6.3		259	1.4	137.31	6.0	6.0			
7.4		221	1.7	117.10	6.0	6.0			
9.1		180	2.0	95.53	6.0	6.0			
11.7		140	2.6	73.96	6.0	6.0			
3.2		505	1.2	267.38	10.0	4.0	D 353 - 71M/6A M 353 - 71M/6A	31	80
4.0		412	1.5	217.97	10.0	4.0			
4.7		349	1.8	185.05	10.0	4.0			
5.7	285	2.2	150.85	10.0	4.0				
6.8	239	2.6	126.43	10.0	4.0				
8.7	188	3.3	99.67	10.0	4.0				
2.4	680	1.5	360.25	18.0	7.2	D 403 - 71M/6A M 403 - 71M/6A	39	82	
2.7	596	1.8	315.51	18.0	7.2				
3.0	551	1.9	292.09	18.0	7.2				
3.5	473	2.2	250.44	18.0	7.2				
4.3	383	2.7	203.06	18.0	7.2				
4.7	349	3.0	184.83	18.0	7.2				
5.4	300	3.5	158.93	18.0	7.2				



P ₁ [kW]	n ₂ [Min ⁻¹]	M ₂ [Nm]	f _B	i _{ges}	F _{R2} (M) [kN]	F _{R2} (D,KS) [kN]	Typ / Type / Tipo / Type / Tipo	 Kg	 mm
0.18	2.2	744	2.3	394.32	22.0	9.0	D 503 - 71M/6A M 503 - 71M/6A	43	84
	2.5	652	2.6	345.35	22.0	9.0			
	2.7	605	2.8	320.49	22.0	9.0			
	3.2	518	3.2	274.13	22.0	9.0			
0.22	5.4	364	1.0	256.27	6.0	6.0	D/M 303 - 71M/4 D/M 303 - 63C/4	26	78
	6.4	309	1.1	217.41	6.0	6.0			
	7.0	382	1.2	198.40	6.0	6.0			
	7.8	252	1.4	177.36	6.0	6.0			
	10.1	195	1.8	137.31	6.0	6.0			
	11.9	166	2.1	117.10	6.0	6.0			
	14.6	136	2.6	95.53	6.0	6.0			
	18.8	105	3.3	73.96	6.0	6.0			
0.25	18.8	122	2.9	73.89	6.0	6.0	D 302 - 71M/4A M 302 - 71M/4A	26	78
	23.7	97	3.6	58.73	6.0	6.0			
	12.3	188	2.0	73.89	6.0	6.0	D 302 - 71M/6B M 302 - 71M/6B	28	78
	15.5	149	2.5	58.73	6.0	6.0			
	17.2	135	2.7	53.04	6.0	6.0			
	19.0	122	3.0	47.91	6.0	6.0			
	21.0	110	3.3	43.27	6.0	6.0			
	22.5	103	3.6	40.53	6.0	6.0			
	24.5	94	3.7	37.09	6.0	6.0			
	27.5	84	3.7	33.07	6.0	6.0			
	29.9	78	3.9	30.46	6.0	6.0			
	8.9	244	1.1	314.13	6.0	6.0	D 303 - 63M/2B M 303 - 63M/2B	24	78
	10.9	199	1.3	256.27	6.0	6.0			
	12.9	169	1.6	217.41	6.0	6.0			
	14.1	154	1.7	198.40	6.0	6.0			
	15.8	138	1.9	177.36	6.0	6.0			
	20.4	107	2.5	137.31	6.0	6.0			
	23.9	91	2.9	117.10	6.0	6.0			
	29.3	74	3.6	95.53	6.0	6.0			
	6.4	351	1.0	217.41	6.0	6.0	D/M 303 - 71M/4A D/M 303 - 63M/4C	26	78
	7.0	320	1.1	198.40	6.0	6.0			
	7.8	286	1.2	177.36	6.0	6.0			
	10.1	222	1.6	137.31	6.0	6.0			
	11.9	189	1.9	117.10	6.0	6.0			
	14.6	154	2.3	95.53	6.0	6.0			
	18.8	119	2.9	73.96	6.0	6.0			
	6.6	342	1.1	137.31	6.0	6.0			
	7.8	292	1.3	117.10	6.0	6.0			
9.5	238	1.5	95.53	6.0	6.0				
12.3	184	2.0	73.96	6.0	6.0				
13.3	174	3.6	68.49	10.0	4.0	D 352 - 71M/6B M 352 - 71M/6B	33	80	
5.2	432	1.4	267.38	10.0	4.0	D 353 - 71M/4A M 353 - 71M/4A	30	80	
6.4	352	1.7	217.97	10.0	4.0				
7.5	299	2.0	185.05	10.0	4.0				
9.2	244	2.5	150.85	10.0	4.0				
11.0	204	2.9	126.43	10.0	4.0				
13.9	161	3.7	99.67	10.0	4.0				
3.4	666	0.9	267.38	10.0	4.0	D 353 - 71M/6B M 353 - 71M/6B	33	80	
4.2	543	1.2	217.97	10.0	4.0				
4.9	461	1.4	185.05	10.0	4.0				
6.0	376	1.7	150.85	10.0	4.0				
7.2	315	2.0	126.43	10.0	4.0				
9.1	248	2.5	99.67	10.0	4.0				
11.2	203	3.1	81.25	10.0	4.0				
3.9	582	1.7	360.25	18.0	7.2				D 403 - 71M/4A M 403 - 71M/4A
4.4	509	2.0	315.51	18.0	7.2				
4.8	472	2.1	292.09	18.0	7.2				
5.6	404	2.5	250.44	18.0	7.2				
6.8	328	3.1	203.06	18.0	7.2				
7.5	298	3.4	184.83	18.0	7.2				
8.7	257	3.9	158.93	18.0	7.2				

P ₁ [kW]	n ₂ [Min ⁻¹]	M ₂ [Nm]	f _B	i _{ges}	F _{R2} (M) [kN]	F _{R2} (D,KS) [kN]	Typ / Type / Tipo / Type / Tipo	 Kg	 mm
0.25	2.5	898	1.2	360.25	18.0	7.2	D 403 - 71M/6B M 403 - 71M/6B	41	82
	2.9	786	1.3	315.51	18.0	7.2			
	3.1	728	1.4	292.09	18.0	7.2			
	3.6	624	1.7	250.44	18.0	7.2			
	4.5	506	2.1	203.06	18.0	7.2			
	4.9	461	2.3	184.83	18.0	7.2			
	5.7	396	2.7	158.93	18.0	7.2			
	7.1	321	3.3	128.86	18.0	7.2			
	7.8	292	3.6	117.30	18.0	7.2			
	3.5	637	2.5	394.32	22.0	9.0	D 503 - 71M/4A M 503 - 71M/4A	49	84
	4.0	558	2.9	345.35	22.0	9.0			
	4.3	517	3.1	320.49	22.0	9.0			
	5.1	443	3.6	274.13	22.0	9.0			
	2.3	983	1.7	394.32	22.0	9.0	D 503 - 71M/6B M 503 - 71M/6B	52	84
	2.6	861	2.0	345.35	22.0	9.0			
2.8	799	2.1	320.49	22.0	9.0				
3.3	683	2.5	274.13	22.0	9.0				
4.1	555	3.0	222.80	22.0	9.0				
4.5	506	3.3	203.06	22.0	9.0				
5.2	434	3.9	173.97	22.0	9.0				
37.9	87	3.1	73.89	6.0	6.0	D 302 - 71M/2A M 302 - 71M/2A			
47.7	69	3.9	58.73	6.0	6.0				
18.8	180	1.9	73.89	6.0	6.0	D 302 - 71M/4B M 302 - 71M/4B	26	78	
23.7	143	2.4	58.73	6.0	6.0				
26.2	129	2.7	53.04	6.0	6.0				
29.0	117	3.0	47.91	6.0	6.0				
32.1	106	3.3	43.27	6.0	6.0				
34.3	99	3.5	40.53	6.0	6.0				
37.5	91	3.6	37.09	6.0	6.0				
42.0	81	3.7	33.07	6.0	6.0				
45.6	74	3.9	30.46	6.0	6.0				
12.5	275	1.3	73.89	6.0	6.0				D/M 302 - 80M/6A D/M 302 - 71C/6
15.7	219	1.7	58.73	6.0	6.0				
17.3	198	1.9	53.04	6.0	6.0				
19.2	178	2.1	47.91	6.0	6.0				
21.3	161	2.3	43.27	6.0	6.0				
22.7	151	2.4	40.53	6.0	6.0				
24.8	138	2.5	37.09	6.0	6.0				
27.8	123	2.6	33.07	6.0	6.0				
30.2	113	2.7	30.46	6.0	6.0				
32.5	105	2.9	28.26	6.0	6.0				
35.1	98	3.1	26.24	6.0	6.0				
37.6	91	3.0	24.47	6.0	6.0				
43.0	80	3.4	21.40	6.0	6.0				
48.6	71	3.6	18.95	6.0	6.0				
12.9	250	1.1	217.41	6.0	6.0	D/M 303 - 71M/2A D/M 303 - 63M/2C	26	78	
14.1	228	1.2	198.40	6.0	6.0				
15.8	204	1.3	177.36	6.0	6.0				
20.4	158	1.7	137.31	6.0	6.0				
23.9	134	2.0	117.10	6.0	6.0				
29.3	110	2.4	95.53	6.0	6.0				
37.9	85	3.1	73.96	6.0	6.0				
10.1	328	1.1	137.31	6.0	6.0	D 303 - 71M/4B M 303 - 71M/4B	26	78	
11.9	280	1.3	117.10	6.0	6.0				
14.6	228	1.5	95.53	6.0	6.0				
18.8	177	2.0	73.96	6.0	6.0				
9.6	349	1.1	95.53	6.0	6.0	D/M 303 - 80M/6A D/M 303 - 71C/6	28	78	
12.4	270	1.4	73.96	6.0	6.0				
20.3	167	3.6	68.49	10.0	4.0	D 352 - 71M/4B M 352 - 71M/4B	32	80	
13.4	255	2.5	68.49	10.0	4.0	D/M 352 - 80M/6A D/M 352 - 71C/6	32	80	
16.5	208	3.0	55.83	10.0	4.0				
16.9	203	3.1	54.36	10.0	4.0				
19.7	174	3.6	46.79	10.0	4.0				
20.8	165	3.8	44.32	10.0	4.0				

P_1 [kW]	n_2 [Min ⁻¹]	M_2 [Nm]	f_B	i_{ges}	$F_{R2} (M)$ [kN]	$F_{R2} (D,KS)$ [kN]	Typ / Type / Tipo / Type / Tipo	 Kg	 mm
0.37	10.5	307	1.5	267.38	10.0	4.0	D 353 - 71M/2A M 353 - 71M/2A	30	80
	12.8	250	1.8	217.97	10.0	4.0			
	15.1	213	2.1	185.05	10.0	4.0			
	18.6	173	2.6	150.85	10.0	4.0			
	22.1	145	3.1	126.43	10.0	4.0			
	28.1	114	4.0	99.67	10.0	4.0			
	5.2	639	0.9	267.38	10.0	4.0	D 353 - 71M/4B M 353 - 71M/4B	32	80
	6.4	521	1.2	217.97	10.0	4.0			
	7.5	442	1.4	185.05	10.0	4.0			
	9.2	360	1.7	150.85	10.0	4.0			
	11.0	302	2.0	126.43	10.0	4.0			
	13.9	238	2.5	99.67	10.0	4.0			
	17.1	194	3.1	81.25	10.0	4.0			
	5.0	675	0.9	185.05	10.0	4.0	D/M 353 - 80M/6A D/M 353 - 71C/6	32	80
	6.1	550	1.1	150.85	10.0	4.0			
	7.3	461	1.4	126.43	10.0	4.0			
	9.2	364	1.7	99.67	10.0	4.0			
	11.3	296	2.1	81.25	10.0	4.0			
	7.8	414	1.8	360.25	18.0	7.2	D 403 - 71M/2A M 403 - 71M/2A	38	82
	8.9	362	2.1	315.51	18.0	7.2			
	9.6	335	2.3	292.09	18.0	7.2			
	11.2	288	2.6	250.44	18.0	7.2			
	13.8	233	3.3	203.06	18.0	7.2			
	15.1	212	3.6	184.83	18.0	7.2			
	3.9	861	1.2	360.25	18.0	7.2	D 403 - 71M/4B M 403 - 71M/4B	40	82
	4.4	754	1.3	315.51	18.0	7.2			
	4.8	698	1.4	292.09	18.0	7.2			
	5.6	598	1.7	250.44	18.0	7.2			
	6.8	485	2.1	203.06	18.0	7.2			
	7.5	442	2.3	184.83	18.0	7.2			
	8.7	380	2.6	158.93	18.0	7.2			
	10.8	308	3.2	128.86	18.0	7.2			
	11.9	280	3.6	117.30	18.0	7.2			
	3.1	1066	1.0	292.09	18.0	7.2			
	3.7	914	1.1	250.44	18.0	7.2			
	4.5	741	1.4	203.06	18.0	7.2			
	5.0	674	1.6	184.83	18.0	7.2			
	5.8	580	1.8	158.93	18.0	7.2			
	7.1	470	2.2	128.86	18.0	7.2			
	7.8	428	2.5	117.30	18.0	7.2			
	10.0	335	3.1	91.83	18.0	7.2	D 403 - 80M/6A M 403 - 80M/6A	41	82
	12.4	272	3.9	74.45	18.0	7.2			
	7.1	453	2.7	394.32	22.0	9.0	D 503 - 71M/2A M 503 - 71M/2A	49	84
	8.1	397	3.1	345.35	22.0	9.0			
	8.7	368	3.3	320.49	22.0	9.0			
	10.2	315	3.9	274.13	22.0	9.0			
	3.5	942	1.7	394.32	22.0	9.0	D 503 - 71M/4B M 503 - 71M/4B	51	84
	4.0	825	1.9	345.35	22.0	9.0			
	4.3	766	2.1	320.49	22.0	9.0			
	5.1	655	2.4	274.13	22.0	9.0			
	6.2	532	3.0	222.80	22.0	9.0			
6.8	485	3.3	203.06	22.0	9.0				
8.0	416	3.8	173.97	22.0	9.0				
2.3	1439	1.2	394.32	22.0	9.0	D/M 503 - 80M/6A D/M 503 - 71C/6	52	84	
2.7	1260	1.3	345.35	22.0	9.0				
2.9	1169	1.4	320.49	22.0	9.0				
3.4	1000	1.7	274.13	22.0	9.0				
4.1	813	2.1	222.80	22.0	9.0				
4.5	741	2.3	203.06	22.0	9.0				
5.3	635	2.6	173.97	22.0	9.0				
6.5	516	3.3	141.39	22.0	9.0				
7.1	470	3.6	128.86	22.0	9.0				
2.7	1254	2.5	343.64	30.0	11.2	D 603 - 80M/6A M 603 - 80M/6A	87	86	
3.1	1098	2.9	300.83	30.0	11.2				
3.3	1021	3.1	279.86	30.0	11.2				
3.9	870	3.6	238.56	30.0	11.2				



P ₁ [kW]	n ₂ [Min ⁻¹]	M ₂ [Nm]	f _B	i _{ges}	F _{R2} (M) [kN]	F _{R2} (D,KS) [kN]	Typ / Type / Tipo / Type / Tipo	 Kg	 mm
0.55	38.2	128	2.1	73.89	6.0	6.0	D 302 - 71M/2B M 302 - 71M/2B	28	78
	48.0	102	2.6	58.73	5.9	5.9			
	53.2	92	2.9	53.04	5.8	5.8			
	58.9	83	3.2	47.91	5.6	5.6			
	65.2	75	3.5	43.27	5.5	5.5			
	69.6	70	3.8	40.53	5.4	5.4			
	76.0	64	3.9	37.09	5.2	5.2			
	85.3	57	3.8	33.07	5.1	5.1			
	18.9	266	1.3	73.89	6.0	6.0	D/M 302 - 80M/4A D/M 302 - 71M/4C	27	78
	23.8	212	1.7	58.73	6.0	6.0			
	26.4	191	1.8	53.04	6.0	6.0			
	29.2	173	2.0	47.91	6.0	6.0			
	32.4	156	2.2	43.27	6.0	6.0			
	34.5	146	2.4	40.53	6.0	6.0			
	37.7	134	2.5	37.09	6.0	6.0			
	42.3	119	2.5	33.07	6.0	6.0			
	46.0	110	2.6	30.46	6.0	6.0			
	49.5	102	2.8	28.26	5.8	5.8			
	53.4	95	3.1	26.24	5.7	5.7			
	57.2	88	2.9	24.47	5.6	5.6			
	65.4	77	3.4	21.40	5.4	5.4			
	73.9	68	3.5	18.95	5.2	5.2			
	15.7	325	1.1	58.73	6.0	6.0	D 302 - 80M/6B M 302 - 80M/6B	30	78
	17.3	294	1.3	53.04	6.0	6.0			
	19.2	265	1.4	47.91	6.0	6.0			
	21.3	240	1.5	43.27	6.0	6.0			
	22.7	224	1.6	40.53	6.0	6.0			
	24.8	205	1.7	37.09	6.0	6.0			
	27.8	183	1.7	33.07	6.0	6.0			
	30.2	169	1.8	30.46	6.0	6.0			
	32.5	157	1.9	28.26	6.0	6.0			
	35.1	145	2.1	26.24	6.0	6.0			
	37.6	136	2.0	24.47	6.0	6.0			
	43.0	119	2.3	21.40	6.0	6.0			
	48.6	105	2.4	18.95	5.9	5.9			
	55.5	92	2.7	16.57	5.7	5.7			
	59.2	86	2.9	15.55	5.6	5.6			
	65.9	77	2.9	13.95	5.4	5.4			
	80.8	63	3.2	11.38	5.1	5.1			
	104.4	49	3.7	8.81	4.8	4.8			
	20.5	233	1.1	137.31	6.0	6.0	D 303 - 71M/2B M 303 - 71M/2B	28	78
	24.1	198	1.3	117.10	6.0	6.0			
	29.5	162	1.6	95.53	6.0	6.0			
	38.1	125	2.1	73.96	6.0	6.0			
	14.7	337	1.0	95.53	6.0	6.0	D/M 303 - 80M/4A D/M 303 - 71M/4C	27	78
	18.9	261	1.3	73.96	6.0	6.0			
	41.2	119	3.8	68.49	10.0	4.0	D 352 - 71M/2B M 352 - 71M/2B	32	80
	20.4	247	2.4	68.49	10.0	4.0	D/M 352 - 80M/4A D/M 352 - 71M/4C	31	80
25.1	201	3.0	55.83	10.0	4.0				
25.8	196	3.1	54.36	10.0	4.0				
29.9	169	3.6	46.79	10.0	4.0				
31.6	160	3.8	44.32	10.0	4.0				
13.4	379	1.7	68.49	10.0	4.0	D 352 - 80M/6B M 352 - 80M/6B	34	80	
16.5	309	2.0	55.83	10.0	4.0				
16.9	301	2.1	54.36	10.0	4.0				
19.7	259	2.4	46.79	10.0	4.0				
20.8	245	2.6	44.32	10.0	4.0				
23.0	222	2.8	40.00	10.0	4.0				
24.8	206	3.1	37.14	10.0	4.0				
26.7	191	3.0	34.50	10.0	4.0				
30.2	169	3.1	30.50	10.0	4.0				
32.7	156	3.2	28.13	10.0	4.0				
36.0	142	3.6	25.56	10.0	4.0				
39.0	131	3.8	23.57	10.0	4.0				



P_1 [kW]	n_2 [Min ⁻¹]	M_2 [Nm]	f_B	i_{ges}	$F_{R2} (M)$ [kN]	$F_{R2} (D,KS)$ [kN]	Typ / Type / Tipo / Type / Tipo	 Kg	 mm
0.55	12.9	369	1.2	217.97	10.0	4.0	D 353 - 71M/2B M 353 - 71M/2B	32	80
	15.2	314	1.5	185.05	10.0	4.0			
	18.7	256	1.8	150.85	10.0	4.0			
	22.3	214	2.1	126.43	10.0	4.0			
	28.3	169	2.7	99.67	10.0	4.0			
	34.7	138	3.3	81.25	10.0	4.0			
	7.6	653	0.9	185.05	10.0	4.0	D/M 353 - 80M/4A D/M 353 - 71M/4C	31	80
	9.3	532	1.1	150.85	10.0	4.0			
	11.1	446	1.3	126.43	10.0	4.0			
	14.0	351	1.7	99.67	10.0	4.0			
	17.2	287	2.1	81.25	10.0	4.0			
	9.2	541	1.2	99.67	10.0	4.0	D 353 - 80M/6B M 353 - 80M/6B	34	80
	11.3	441	1.4	81.25	10.0	4.0			
	15.1	338	3.1	61.05	18.0	7.2	D 402 - 80M/6B M 402 - 80M/6B	43	82
	17.2	296	3.5	53.44	18.0	7.2			
	18.6	274	3.8	49.50	18.0	7.2			
	7.8	611	1.2	360.25	18.0	7.2	D 403 - 71M/2B M 403 - 71M/2B	40	82
	8.9	535	1.4	315.51	18.0	7.2			
	9.7	495	1.5	292.09	18.0	7.2			
	11.3	224	1.8	250.44	18.0	7.2			
	13.9	344	2.2	203.06	18.0	7.2			
	15.3	313	2.4	184.83	18.0	7.2			
	17.7	269	2.8	158.93	18.0	7.2			
	21.9	218	3.5	128.86	18.0	7.2			
	24.0	199	3.8	117.30	18.0	7.2			
	4.8	1030	1.0	292.09	18.0	7.2			
	5.6	883	1.1	250.44	18.0	7.2			
	6.9	716	1.4	203.06	18.0	7.2			
	7.6	652	1.5	184.83	18.0	7.2			
	8.8	561	1.8	158.93	18.0	7.2			
	10.9	454	2.2	128.86	18.0	7.2			
	11.9	414	2.4	117.30	18.0	7.2			
	15.2	324	3.1	91.83	18.0	7.2	D 403 - 80M/4A M 403 - 80M/4A	40	82
	18.8	263	3.8	74.45	18.0	7.2			
	4.5	1101	1.0	203.06	18.0	7.2	D 403 - 80M/6B M 403 - 80M/6B	43	82
	5.0	1003	1.0	184.83	18.0	7.2			
	5.8	862	1.2	158.93	18.0	7.2			
	7.1	699	1.5	128.86	18.0	7.2			
	7.8	636	1.7	117.30	18.0	7.2			
	10.0	498	2.1	91.83	18.0	7.2			
	12.4	404	2.6	74.45	18.0	7.2			
	13.6	368	2.9	67.77	18.0	7.2			
	7.2	668	1.8	394.32	22.0	9.0	D 503 - 71M/2B M 503 - 71M/2B	51	84
	8.2	585	2.1	345.35	22.0	9.0			
	8.8	543	2.2	320.49	22.0	9.0			
	10.3	465	2.6	274.13	22.0	9.0			
	12.7	378	3.2	222.80	22.0	9.0			
13.9	344	3.5	203.06	22.0	9.0				
3.6	1391	1.2	394.32	22.0	9.0	D/M 503 - 80M/4A D/M 503 - 71M/4C	51	84	
4.1	1218	1.3	345.35	22.0	9.0				
4.4	1130	1.4	320.49	22.0	9.0				
5.1	967	1.7	274.13	22.0	9.0				
6.3	786	2.0	222.80	22.0	9.0				
6.9	716	2.2	203.06	22.0	9.0				
8.0	614	2.6	173.97	22.0	9.0				
9.9	499	3.2	141.39	22.0	9.0				
10.9	454	3.5	128.86	22.0	9.0				
2.9	1738	1.0	320.49	22.0	9.0				D 503 - 80M/6B M 503 - 80M/6B
3.4	1487	1.1	274.13	22.0	9.0				
4.1	1208	1.4	222.80	22.0	9.0				
4.5	1101	1.5	203.06	22.0	9.0				
5.3	944	1.8	173.97	22.0	9.0				
6.5	767	2.2	141.39	22.0	9.0				
7.1	699	2.4	128.86	22.0	9.0				
8.3	601	2.8	110.73	22.0	9.0				
9.2	545	3.1	100.51	22.0	9.0				
11.3	443	3.8	81.69	22.0	9.0				

P ₁ [kW]	n ₂ [Min ⁻¹]	M ₂ [Nm]	f _B	i _{ges}	F _{R2} (M) [kN]	F _{R2} (D,KS) [kN]	Typ / Type / Tipo / Type / Tipo	 Kg	 mm					
0.55	4.1	1212	2.5	343.64	30.0	11.2	D 603 - 80M/4A M 603 - 80M/4A	86	86					
	4.7	1061	2.8	300.83	30.0	11.2								
	5.0	987	3.0	279.86	30.0	11.2								
	5.9	841	3.6	238.56	30.0	11.2								
	0.75	2.7	1864	1.7	343.64	30.0	11.2	D 603 - 80M/6B M 603 - 80M/6B	88	86				
		3.1	1632	1.9	300.83	30.0	11.2							
		3.3	1518	2.1	279.86	30.0	11.2							
		3.9	1294	2.4	238.56	30.0	11.2							
		4.7	1054	3.0	194.28	30.0	11.2							
		5.2	961	3.3	177.25	30.0	11.2							
		6.1	819	3.8	150.99	30.0	11.2							
		0.75	38.4	173	1.5	73.89	6.0				6.0	D/M 302 - 80M/2A D/M 302 - 71M/2C	27	78
			48.4	138	1.9	58.73	5.7				5.7			
			53.5	124	2.1	53.04	5.6				5.6			
59.3	112		2.4	47.91	5.4	5.4								
65.6	101		2.6	43.27	5.3	5.3								
70.1	95		2.8	40.53	5.2	5.2								
76.6	87		2.9	37.09	5.1	5.1								
85.9	78		2.9	33.07	4.9	4.9								
93.2	71		3.1	30.46	4.8	4.8								
100.5	66		3.3	28.26	4.7	4.7								
108.2	62		3.6	26.24	4.6	4.6								
116.0	57		3.4	24.47	4.5	4.5								
132.7	50		3.9	21.40	4.4	4.4								
0.75	18.9		363	1.0	73.89	6.0	6.0	D 302 - 80M/4B M 302 - 80M/4B	29	78				
	23.8		288	1.2	58.73	6.0	6.0							
	26.4		261	1.3	53.04	6.0	6.0							
	29.2		235	1.5	47.91	6.0	6.0							
	32.4		213	1.6	43.27	6.0	6.0							
	34.5		199	1.8	40.53	6.0	6.0							
	37.7		182	1.8	37.09	6.0	6.0							
	42.3		162	1.8	33.07	5.8	5.8							
	46.0		150	1.9	30.46	5.7	5.7							
	49.5		139	2.1	28.26	5.6	5.6							
	53.4		129	2.3	26.24	5.5	5.5							
	57.2		120	2.2	24.47	5.4	5.4							
0.75	65.4		105	2.5	21.40	5.3	5.3	D/M 302 - 90S/6A D/M 302 - 80C/6	32	78				
	73.9	93	2.6	18.95	5.1	5.1								
	84.5	81	2.9	16.57	4.9	4.9								
	90.1	76	3.1	15.55	4.8	4.8								
	100.3	69	3.1	13.95	4.7	4.7								
	123.0	56	3.4	11.38	4.4	4.4								
	17.4	398	0.9	53.04	6.0	6.0								
	19.3	360	1.0	47.91	6.0	6.0								
	21.4	325	1.1	43.27	6.0	6.0								
	22.8	304	1.2	40.53	6.0	6.0								
	24.9	279	1.2	37.09	6.0	6.0								
	28.0	248	1.3	33.07	6.0	6.0								
	30.4	229	1.3	30.46	6.0	6.0								
	32.7	212	1.4	28.26	6.0	6.0								
	35.3	197	1.5	26.24	6.0	6.0								
	37.8	184	1.5	24.47	6.0	6.0								
	43.2	161	1.7	21.40	5.8	5.8								
	48.8	142	1.8	18.95	5.7	5.7								
55.8	124	2.0	16.57	5.5	5.5									
59.5	117	2.2	15.55	5.4	5.4									
66.3	105	2.1	13.95	5.3	5.3									
81.3	85	2.3	11.38	5.0	5.0									
105.0	66	2.7	8.81	4.7	4.7									
0.75	29.7	219	1.2	95.53	6.0	6.0	D/M 303 - 80M/2A D/M 303 - 71M/2C	27	78					
	38.4	170	1.6	73.96	6.0	6.0								
0.75	18.9	356	1.0	73.96	6.0	6.0	D 303 - 80M/4B M 303 - 80M/4B	29	78					
0.75	41.5	161	2.8	68.49	10.0	4.0	D/M 352 - 80M/2A D/M 352 - 71M/2C	31	80					
	50.9	131	3.5	55.83	10.0	4.0								
	52.2	128	3.6	54.36	10.0	4.0								



P ₁ [kW]	n ₂ [Min ⁻¹]	M ₂ [Nm]	f _B	i _{ges}	F _{R2} (M) [kN]	F _{R2} (D,KS) [kN]	Typ / Type / Tipo / Type / Tipo	Kg ~	mm	
0.75	20.4	336	1.8	68.49	10.0	4.0	D 352 - 80M/4B M 352 - 80M/4B	33	80	
	25.1	274	2.2	55.83	10.0	4.0				
	25.8	267	2.2	54.36	10.0	4.0				
	29.9	230	2.6	46.79	10.0	4.0				
	31.6	218	2.8	44.32	10.0	4.0				
	35.0	196	3.1	40.00	10.0	4.0				
	37.7	182	3.3	37.14	10.0	4.0				
	40.6	169	3.2	34.50	10.0	4.0				
	45.9	150	3.3	30.50	10.0	4.0				
	49.8	138	3.5	28.13	10.0	4.0				
	54.8	126	3.8	25.56	9.9	4.0				
		13.5	514	1.2	68.49	10.0	4.0	D/M 352 - 90S/6A D/M 352 - 80C/6	36	80
		16.6	419	1.5	55.83	10.0	4.0			
		17.0	408	1.5	54.36	10.0	4.0			
		19.8	351	1.8	46.79	10.0	4.0			
		20.9	333	1.9	44.32	10.0	4.0			
		23.1	300	2.1	40.00	10.0	4.0			
		24.9	279	2.3	37.14	10.0	4.0			
		26.8	259	2.2	34.50	10.0	4.0			
		30.3	229	2.3	30.50	10.0	4.0			
		32.9	211	2.4	28.13	10.0	4.0			
		36.2	192	2.6	25.56	10.0	4.0	D/M 353 - 80M/2A D/M 353 - 71M/2C	31	80
		39.2	177	2.8	23.57	10.0	4.0			
		46.4	150	3.2	19.93	10.0	4.0			
		56.9	122	3.9	16.25	9.8	3.9			
		15.3	425	1.1	185.05	10.0	4.0			
		18.8	346	1.3	150.85	10.0	4.0			
		22.5	290	1.6	126.43	10.0	4.0			
		28.5	229	2.0	99.67	10.0	4.0			
		35.0	186	2.4	81.25	10.0	4.0			
		11.1	608	1.0	126.43	10.0	4.0			
		14.0	479	1.3	99.67	10.0	4.0			
		17.2	391	1.5	81.25	10.0	4.0			
		11.4	598	1.1	81.25	10.0	4.0	D/M 353 - 90S/6A D/M 353 - 80C/6	36	80
		22.9	300	3.3	61.05	18.0	7.2	D 402 - 80M/4B M 402 - 80M/4B	42	82
		26.2	262	3.8	53.44	18.0	7.2			
		15.2	459	2.3	61.05	18.0	7.2	D/M 402 - 90S/6A D/M 402 - 80C/6	45	82
		17.3	401	2.6	53.44	18.0	7.2			
		18.7	372	2.8	49.50	18.0	7.2			
		21.8	318	3.3	42.38	18.0	7.2			
		23.5	296	3.5	39.44	18.0	7.2			
		26.9	258	4.1	34.36	18.0	7.2			
		9.0	724	1.0	315.51	18.0	7.2	D 403 - 71M/2C M 403 - 71M/2C	40	82
		9.7	670	1.1	292.09	18.0	7.2	D/M 403 - 80M/2A D/M 403 - 71M/2C	40	82
		11.3	575	1.3	250.44	18.0	7.2			
		14.0	466	1.6	203.06	18.0	7.2			
		15.4	424	1.8	184.83	18.0	7.2			
		17.9	365	2.1	158.93	18.0	7.2			
		22.0	296	2.6	128.86	18.0	7.2			
		24.2	269	2.8	117.30	18.0	7.2	D 403 - 80M/2A M 403 - 80M/2A	40	82
		30.9	211	3.6	91.83	18.0	7.0			
		6.9	977	1.0	203.06	18.0	7.2	D 403 - 80M/4B M 403 - 80M/4B	42	82
		7.6	889	1.1	184.83	18.0	7.2			
		8.8	764	1.3	158.93	18.0	7.2			
		10.9	620	1.6	128.86	18.0	7.2			
		11.9	564	1.8	117.30	18.0	7.2			
		15.2	442	2.3	91.83	18.0	7.2			
		18.8	358	2.8	74.45	18.0	7.2			
		20.7	326	3.1	67.77	18.0	7.2			



P₁ [kW]	n₂ [Min ⁻¹]	M₂ [Nm]	f_B	i_{ges}	F_{R2} (M) [kN]	F_{R2} (D,KS) [kN]	Typ / Type / Tipo / Type / Tipo	Kg ~	
0.75	7.2	948	1.1	128.86	18.0	7.2	D/M 403 - 90S/6A D/M 403 - 80C/6	45	82
	7.9	863	1.2	117.30	18.0	7.2			
	10.1	675	1.6	91.83	18.0	7.2			
	12.4	548	1.9	74.45	18.0	7.2			
	13.6	499	2.1	67.77	18.0	7.2			
	13.8	502	3.3	66.83	22.0	9.0			
	15.8	439	3.8	58.50	22.0	9.0	D/M 502 - 90S/6A D/M 502 - 80C/6	56	84
	17.0	408	3.3	54.31	22.0	9.0			
	7.5	874	1.4	394.32	22.0	9.0			
	8.5	766	1.6	345.35	22.0	9.0	D/M 503 - 80M/2A D/M 503 - 71M/2C	51	84
	9.2	711	1.7	320.49	22.0	9.0			
	10.7	608	2.0	274.13	22.0	9.0			
	13.2	494	2.5	222.80	22.0	9.0			
	14.5	450	2.7	203.06	22.0	9.0			
	16.9	386	3.2	173.97	22.0	9.0			
	20.8	313	3.9	141.39	22.0	9.0			
	4.1	1661	1.0	345.35	22.0	9.0			
	4.4	1541	1.0	320.49	22.0	9.0			
	5.1	1318	1.2	274.13	22.0	9.0			
	6.3	1071	1.5	222.80	22.0	9.0			
	6.9	977	1.6	203.06	22.0	9.0			
	8.0	837	1.9	173.97	22.0	9.0			
	9.9	680	2.4	141.39	22.0	9.0			
	10.9	620	2.6	128.86	22.0	9.0			
	12.6	532	3.0	110.73	22.0	9.0			
	13.9	483	3.3	100.51	22.0	9.0			
	4.2	1639	1.0	222.80	22.0	9.0	D/M 503 - 90S/6A D/M 503 - 80C/6	56	84
	4.6	1494	1.1	203.06	22.0	9.0			
	5.3	1280	1.3	173.97	22.0	9.0			
	6.5	1040	1.6	141.39	22.0	9.0			
	7.2	948	1.8	128.86	22.0	9.0			
	8.4	815	2.1	110.73	22.0	9.0			
	9.2	739	2.3	100.51	22.0	9.0			
	11.3	601	2.8	81.69	22.0	9.0			
	12.4	548	3.1	74.45	22.0	9.0			
	8.6	762	3.0	343.64	30.0	11.2	D 603 - 80M/2A M 603 - 80M/2A	86	86
9.8	667	3.4	300.83	30.0	11.2				
10.5	620	3.7	279.86	30.0	11.2				
4.1	1653	1.8	343.64	30.0	11.2	D 603 - 80M/4B M 603 - 80M/4B	88	86	
4.7	1447	2.1	300.83	30.0	11.2				
5.0	1346	2.2	279.86	30.0	11.2				
5.9	1147	2.6	238.56	30.0	11.2				
7.2	934	3.2	194.28	30.0	11.2				
7.9	852	3.5	177.25	30.0	11.2				
2.7	2528	1.2	343.64	30.0	11.2	D/M 603 - 90S/6A D/M 603 - 80C/6	91	86	
3.1	2213	1.4	300.83	30.0	11.2				
3.3	2059	1.5	279.86	30.0	11.2				
3.9	1755	1.8	238.56	30.0	11.2				
4.8	1429	2.2	194.28	30.0	11.2				
5.2	1304	2.4	177.25	30.0	11.2				
6.1	1111	2.8	150.99	30.0	11.2				
6.9	982	3.2	133.43	30.0	11.2				
7.5	905	3.5	122.97	30.0	11.2				
8.2	825	3.8	112.19	30.0	11.2				



P_1 [kW]	n_2 [Min ⁻¹]	M_2 [Nm]	f_B	i_{ges}	$F_{R2} (M)$ [kN]	$F_{R2} (D,KS)$ [kN]	Typ / Type / Tipo / Type / Tipo	 Kg ~	 mm	
0.92	24.0	351	1.0	58.73	6.0	6.0	D 302 - 80M/4 M 302 - 80M/4	29	78	
	26.6	317	1.1	53.04	6.0	6.0				
	29.4	287	1.2	47.91	6.0	6.0				
	32.6	259	1.4	43.27	5.9	5.9				
	34.8	242	1.4	40.53	5.8	5.8				
	38.0	222	1.5	37.09	5.7	5.7				
	42.6	198	1.5	33.07	5.6	5.6				
	46.3	182	1.6	30.46	5.5	5.5				
	49.9	169	1.7	28.26	5.4	5.4				
	53.7	157	1.8	26.24	5.4	5.4				
	57.6	146	1.8	24.47	5.3	5.3				
	65.9	128	2.0	21.40	5.1	5.1				
	74.4	113	2.1	18.95	5.0	5.0				
	85.1	99	2.4	16.57	4.8	4.8				
	90.7	93	2.6	15.55	4.7	4.7				
	101.1	83	2.5	13.95	4.6	4.6				
	123.9	68	2.8	11.38	4.4	4.4				
	160.0	53	3.2	8.81	4.1	4.1				
		20.6	410	1.5	68.49	10.0	4.0	D 352 - 80M/4 M 352 - 80M/4	33	80
		25.3	334	1.8	55.83	10.0	4.0			
		25.9	325	1.8	54.36	10.0	4.0			
		30.1	280	2.1	46.79	10.0	4.0			
		31.8	265	2.3	44.32	10.0	4.0			
		35.3	239	2.5	40.00	10.0	4.0			
		38.0	222	2.7	37.14	10.0	4.0			
		40.9	206	2.9	34.50	10.0	4.0			
		46.2	182	2.7	30.50	10.0	4.0			
		50.1	168	2.9	28.13	10.0	4.0			
		55.2	153	3.1	25.56	9.7	3.9			
		59.8	141	3.3	23.57	9.5	3.8			
		70.7	119	3.9	19.93	9.1	3.6			
		14.1	584	1.0	99.67	10.0	4.0	D 353 - 80M/4 M 353 - 80M/4	33	80
		17.4	476	1.3	81.25	10.0	4.0			
		23.1	365	2.7	61.05	18.0	7.2	D 402 - 80M/4 M 402 - 80M/4	42	82
		26.4	320	3.1	53.44	18.0	7.2			
	28.5	296	3.4	49.50	18.0	7.1				
	33.3	254	3.9	42.38	18.0	6.8				
	7.6	1083	0.9	184.83	18.0	7.2	D 403 - 80M/4 M 403 - 80M/4	42	82	
	8.9	931	1.1	158.93	18.0	7.2				
	10.9	755	1.3	128.86	18.0	7.2				
	12.0	687	1.5	117.30	18.0	7.2				
	15.4	538	1.9	91.83	18.0	7.2				
	18.9	436	2.3	74.45	18.0	7.2				
	20.8	397	2.5	67.77	18.0	7.2				
	21.1	400	4.0	66.83	22.0	9.0	D 502 - 80M/4 M 502 - 80M/4	53	84	
	26.0	325	4.0	54.31	22.0	9.0				
	5.1	1606	1.0	274.13	22.0	9.0	D 503 - 80M/4 M 503 - 80M/4	53	84	
	6.3	1305	1.2	222.80	22.0	9.0				
	6.9	1189	1.3	203.06	22.0	9.0				
	8.1	1019	1.6	173.97	22.0	9.0				
	10.0	828	1.9	141.39	22.0	9.0				
	10.9	755	2.1	128.86	22.0	9.0				
	12.7	649	2.5	110.73	22.0	9.0				
	14.0	589	2.7	100.51	22.0	9.0				
	17.3	479	3.3	81.69	22.0	9.0				
	18.9	436	3.7	74.45	22.0	9.0				
	4.1	2013	1.5	343.64	30.0	11.2	D 603 - 80M/4 M 603 - 80M/4	87	86	
	4.7	1762	1.7	300.83	30.0	11.2				
	5.0	1639	1.8	279.86	30.0	11.2				
	5.9	1397	2.1	238.56	30.0	11.2				
	7.3	1138	2.6	194.28	30.0	11.2				
	8.0	1038	2.9	177.25	30.0	11.2				
	9.3	884	3.4	150.99	30.0	11.2				
	10.6	782	3.8	133.43	30.0	11.2				

P ₁ [kW]	n ₂ [Min ⁻¹]	M ₂ [Nm]	f _B	i _{ges}	F _{R2} (M) [kN]	F _{R2} (D,KS) [kN]	Typ / Type / Tipo / Type / Tipo	 Kg ~	 mm
1.10	38.6	253	1.1	73.89	5.5	5.5	D 302 - 80M/2B M 302 - 80M/2B	27	78
	48.5	201	1.3	58.73	5.3	5.3			
	53.7	182	1.5	53.04	5.2	5.2			
	59.5	164	1.6	47.91	5.1	5.1			
	65.9	148	1.8	43.27	5.0	5.0			
	70.3	139	1.9	40.53	4.9	4.9			
	76.8	127	2.0	37.09	4.9	4.9			
	86.2	113	2.0	33.07	4.7	4.7			
	93.6	104	2.1	30.46	4.6	4.6			
	100.8	97	2.3	28.26	4.5	4.5			
	108.6	90	2.5	26.24	4.5	4.5			
	116.5	84	2.4	24.47	4.4	4.4			
	133.1	73	2.7	21.40	4.2	4.2			
	150.4	65	2.8	18.95	4.1	4.1			
	172.0	57	3.2	16.57	4.0	4.0			
183.3	53	3.4	15.55	3.9	3.9				
204.3	48	3.3	13.95	3.8	3.8				
250.4	39	3.7	11.38	3.6	3.6				
	26.6	379	0.9	53.04	5.7	5.7	D/M 302 - 90S/4A D/M 302 - 80M/4C	32	78
	29.4	343	1.0	47.91	5.7	5.7			
	32.6	309	1.1	43.27	5.6	5.6			
	34.8	290	1.2	40.53	5.6	5.6			
	38.0	265	1.2	37.09	5.5	5.5			
	42.6	237	1.3	33.07	5.4	5.4			
	46.3	218	1.3	30.46	5.3	5.3			
	49.9	202	1.4	28.26	5.3	5.3			
	53.7	188	1.5	26.24	5.2	5.2			
	57.6	175	1.5	24.47	5.1	5.1			
	65.9	153	1.7	21.40	5.0	5.0			
	74.4	136	1.8	18.95	4.8	4.8			
	85.1	119	2.0	16.57	4.7	4.7			
	90.7	111	2.2	15.55	4.6	4.6			
	101.1	100	2.1	13.95	4.5	4.5			
123.9	81	2.3	11.38	4.3	4.3				
160.0	63	2.7	8.81	4.0	4.0				
	33.1	308	1.0	28.26	5.6	5.6	D 302 - 90L/6B M 302 - 90L/6B	36	78
	35.6	286	1.1	26.24	5.6	5.6			
	38.2	267	1.0	24.47	5.5	5.5			
	43.7	233	1.2	21.40	5.4	5.4			
	49.3	206	1.2	18.95	5.3	5.3			
	56.4	181	1.4	16.57	5.2	5.2			
	60.1	169	1.5	15.55	5.1	5.1			
	67.0	152	1.5	13.95	5.0	5.0			
82.1	124	1.6	11.38	4.8	4.8				
106.1	96	1.9	8.81	4.5	4.5				
	38.5	248	1.1	73.96	5.6	5.6	D 303 - 80M/2B M 303 - 80M/2B	27	78
	41.6	235	1.9	68.49	10.0	4.0	D 352 - 80M/2B M 352 - 80M/2B	31	80
	51.0	191	2.4	55.83	9.8	3.9			
	52.4	186	2.4	54.36	9.7	3.9			
	60.9	160	2.8	46.79	9.4	3.7			
	64.3	152	3.0	44.32	9.2	3.7			
	71.3	137	3.3	40.00	9.0	3.6			
	76.7	127	3.6	37.14	8.8	3.5			
	82.6	118	3.5	34.50	8.6	3.5			
	93.4	105	3.6	30.50	8.3	3.3			
	101.3	96	3.8	28.13	8.2	3.3			



P ₁ [kW]	n ₂ [Min ⁻¹]	M ₂ [Nm]	f _B	i _{ges}	F _{R2} (M) [kN]	F _{R2} (D,KS) [kN]	Typ / Type / Tipo / Type / Tipo	Kg ~ 	
1.10	20.6	490	1.2	68.49	10.0	4.0	D/M 352 - 90S/4A D/M 352 - 80M/4C	36	80
	25.3	399	1.5	55.83	10.0	4.0			
	25.9	389	1.5	54.36	10.0	4.0			
	30.1	335	1.8	46.79	10.0	4.0			
	31.8	317	1.9	44.32	10.0	4.0			
	35.3	286	2.1	40.00	10.0	4.0			
	38.0	266	2.3	37.14	10.0	4.0			
	40.9	247	2.2	34.50	10.0	4.0			
	46.2	218	2.3	30.50	9.9	4.0			
	50.1	201	2.4	28.13	9.8	3.9			
55.2	183	2.6	25.56	9.5	3.8				
59.8	169	2.8	23.57	9.3	3.7				
70.7	143	2.5	19.93	8.9	3.6				
86.8	116	3.0	16.25	8.5	3.4				
	16.7	608	1.0	55.83	10.0	4.0	D 352 - 90L/6B M 352 - 90L/6B	40	80
	17.2	592	1.1	54.36	10.0	4.0			
	20.0	510	1.2	46.79	10.0	4.0			
	21.1	483	1.3	44.32	10.0	4.0			
	23.4	436	1.4	40.00	10.0	4.0			
	25.2	405	1.6	37.14	10.0	4.0			
	27.1	376	1.5	34.50	10.0	4.0			
	30.7	332	1.6	30.50	10.0	4.0			
	33.2	307	1.6	28.13	10.0	4.0			
	36.6	279	1.8	25.56	10.0	4.0			
	39.7	257	1.9	23.57	10.0	4.0			
	46.9	217	2.2	19.93	10.0	4.0			
	57.5	177	2.7	16.25	9.5	3.8			
	68.7	148	3.0	13.62	9.1	3.6			
	78.0	131	3.1	11.99	8.8	3.5			
95.7	107	3.5	9.77	8.3	3.3				
114.2	89	3.9	8.19	7.9	3.2				
	22.5	424	1.1	126.43	10.0	4.0	D 353 - 80M/2B M 353 - 80M/2B	31	80
	28.6	334	1.4	99.67	10.0	4.0			
	35.1	273	1.7	81.25	10.0	4.0			
	17.4	569	1.1	81.25	10.0	4.0	D/M 353 - 90S/4A D/M 353 - 80M/4C	36	80
	46.7	209	3.6	61.05	18.0	6.2			
	53.3	183	4.1	53.44	18.0	5.9	D 402 - 80M/2B M 402 - 80M/2B	40	82
	23.1	437	2.3	61.05	18.0	7.2			
	26.4	382	2.6	53.44	18.0	7.2	D/M 402 - 90S/4A D/M 402 - 80M/4C	45	82
	28.5	354	2.8	49.50	18.0	7.1			
	33.3	303	3.3	42.38	18.0	6.8			
	35.7	282	3.5	39.44	18.0	6.7			
	41.0	246	4.1	34.36	18.0	6.4			
	15.3	665	1.6	61.05	18.0	7.2			
	17.5	582	1.8	53.44	18.0	7.2	D 402 - 90L/6B M 402 - 90L/6B	49	82
	18.9	539	1.9	49.50	18.0	7.2			
	22.1	462	2.3	42.38	18.0	7.2			
	23.7	430	2.4	39.44	18.0	7.2			
	27.2	375	2.8	34.36	18.0	7.2			
	29.9	341	3.1	31.28	18.0	7.1			
	33.1	308	3.1	28.22	18.0	6.9			
	34.9	292	3.2	26.83	18.0	6.8			
	39.6	257	3.3	23.60	18.0	6.5			
	43.0	237	3.5	21.75	18.0	6.3			
47.2	216	3.7	19.80	18.0	6.2				
	14.0	681	1.1	203.06	18.0	7.2	D 403 - 80M/2B M 403 - 80M/2B	40	82
	15.4	620	1.2	184.83	18.0	7.2			
	17.9	533	1.4	158.93	18.0	7.2			
	22.1	432	1.8	128.86	18.0	7.2			
	24.3	393	1.9	117.30	18.0	7.2			
	31.0	308	2.5	91.83	18.0	6.9			
	38.3	250	3.0	74.45	18.0	6.5			
	42.1	227	3.3	67.77	18.0	6.3			

P ₁ [kW]	n ₂ [Min ⁻¹]	M ₂ [Nm]	f _B	i _{ges}	F _{R2} (M) [kN]	F _{R2} (D,KS) [kN]	Typ / Type / Tipo / Type / Tipo	 Kg	 mm
1.10	10.9	902	1.1	128.86	18.0	7.2	D/M 403 - 90S/4A D/M 403 - 80M/4C	45	82
	12.0	821	1.2	117.30	18.0	7.2			
	15.4	643	1.6	91.83	18.0	7.2			
	18.9	521	1.9	74.45	18.0	7.2			
	20.8	475	2.1	67.77	18.0	7.2			
	10.2	980	0.8	91.83	18.0	7.2	D 403 - 90L/6B M 403 - 90L/6B	49	82
	12.6	795	1.0	74.45	18.0	7.2			
	13.8	723	1.1	67.77	18.0	7.2			
	21.1	478	3.3	66.83	22.0	9.0	D/M 502 - 90S/4A D/M 502 - 80M/4C	56	84
	24.1	418	3.8	58.50	22.0	9.0			
	26.0	388	3.3	54.31	22.0	9.0			
	14.0	728	2.3	66.83	22.0	9.0	D 502 - 90L/6B M 502 - 90L/6B	60	84
	16.0	638	2.6	58.50	22.0	9.0			
	17.2	592	2.3	54.31	22.0	9.0			
	20.2	506	3.3	46.39	22.0	9.0			
	21.6	472	2.9	43.33	22.0	9.0			
	24.8	411	3.8	37.70	22.0	9.0			
	27.2	375	3.9	34.36	22.0	9.0			
	8.3	1158	1.0	345.35	22.0	9.0	D 503 - 80M/2B M 503 - 80M/2B	51	84
	8.9	1075	1.1	320.49	22.0	9.0			
	10.4	919	1.3	274.13	22.0	9.0			
	12.8	747	1.6	222.80	22.0	9.0			
	14.0	681	1.8	203.06	22.0	9.0			
	16.4	584	2.1	173.97	22.0	9.0			
	20.2	474	2.6	141.39	22.0	9.0			
	22.1	432	2.8	128.86	22.0	9.0			
	25.7	371	3.3	110.73	22.0	9.0			
	28.4	337	3.6	100.51	22.0	8.8			
	6.3	1560	1.0	222.80	22.0	9.0	D/M 503 - 90S/4A D/M 503 - 80M/4C	56	84
	6.9	1422	1.1	203.06	22.0	9.0			
	8.1	1218	1.3	173.97	22.0	9.0			
	10.0	990	1.6	141.39	22.0	9.0			
	10.9	902	1.8	128.86	22.0	9.0			
	12.7	775	2.1	110.73	22.0	9.0			
	14.0	704	2.3	100.51	22.0	9.0			
	17.3	572	2.8	81.69	22.0	9.0			
	18.9	521	3.1	74.45	22.0	9.0			
	6.6	1509	1.1	141.39	22.0	9.0	D 503 - 90L/6B M 503 - 90L/6B	60	84
	7.3	1375	1.2	128.86	22.0	9.0			
	8.4	1182	1.4	110.73	22.0	9.0			
	9.3	1073	1.6	100.51	22.0	9.0			
	11.4	872	1.9	81.69	22.0	9.0			
	12.6	795	2.1	74.45	22.0	9.0			
	8.3	1153	2.0	343.64	30.0	11.2	D 603 - 80M/2B M 603 - 80M/2B	86	86
9.5	1009	2.3	300.83	30.0	11.2				
10.2	939	2.4	279.86	30.0	11.2				
11.9	800	2.8	238.56	30.0	11.2				
14.7	652	3.5	194.28	30.0	11.2				
16.1	595	3.8	177.25	30.0	11.2				
4.1	2407	1.2	343.64	30.0	11.2	D/M 603 - 90S/4A D/M 603 - 80M/4C			
4.7	2107	1.4	300.83	30.0	11.2				
5.0	1960	1.5	279.86	30.0	11.2				
5.9	1671	1.8	238.56	30.0	11.2				
7.3	1361	2.2	194.28	30.0	11.2				
8.0	1241	2.4	177.25	30.0	11.2				
9.3	1057	2.8	150.99	30.0	11.2				
10.6	934	3.2	133.43	30.0	11.2				
11.5	861	3.5	122.97	30.0	11.2				
12.6	786	3.8	112.19	30.0	11.2				



P_1 [kW]	n_2 [Min ⁻¹]	M_2 [Nm]	f_B	i_{ges}	$F_{R2} (M)$ [kN]	$F_{R2} (D,KS)$ [kN]	Typ / Type / Tipo / Type / Tipo	 Kg	 mm
1.10	3.1	3211	1.0	300.83	30.0	11.2	D 603 - 90L/6B M 603 - 90L/6B	95	86
	3.3	2987	1.1	279.86	30.0	11.2			
	3.9	2546	1.2	238.56	30.0	11.2			
	4.8	2074	1.5	194.28	30.0	11.2			
	5.3	1892	1.7	177.25	30.0	11.2			
	6.2	1612	2.0	150.99	30.0	11.2			
	7.0	1424	2.2	133.43	30.0	11.2			
	7.6	1313	2.4	122.97	30.0	11.2			
8.3	1197	2.6	112.19	30.0	11.2				
1.50	56.7	245	1.0	16.57	4.8	4.8	D 302 - 100L/6A M 302 - 100L/6A	40	78
	60.5	230	1.1	15.55	4.7	4.7			
	67.4	206	1.1	13.95	4.7	4.7			
	82.6	168	1.2	11.38	4.5	4.5			
	106.7	130	1.4	8.81	4.3	4.3			
	53.9	247	1.1	53.04	4.9	4.9	D/M 302 - 90S/2A D/M 302 - 80M/2C	33	78
	59.7	223	1.2	47.91	4.8	4.8			
	66.1	202	1.3	43.27	4.7	4.7			
	70.6	189	1.4	40.53	4.7	4.7			
	77.1	173	1.5	37.09	4.6	4.6			
	86.5	154	1.5	33.07	4.5	4.5			
	93.9	142	1.6	30.46	4.4	4.4			
	101.2	132	1.7	28.26	4.3	4.3			
	109.0	122	1.8	26.24	4.3	4.3			
	116.9	114	1.7	24.47	4.2	4.2			
	133.6	100	2.0	21.40	4.1	4.1			
	150.9	88	2.1	18.95	4.0	4.0			
	172.6	77	2.4	16.57	3.8	3.8			
	184.0	72	2.5	15.55	3.8	3.8			
	205.0	65	2.5	13.95	3.7	3.7			
	251.3	53	2.7	11.38	3.5	3.5			
	324.5	41	3.1	8.81	3.2	3.2			
	38.3	359	0.9	37.09	4.9	4.9	D 302 - 90L/4A M 302 - 90L/4A	34	78
	42.9	320	0.9	33.07	4.9	4.9			
	46.6	295	1.0	30.46	4.9	4.9			
	50.2	274	1.1	28.26	4.8	4.8			
	54.1	254	1.1	26.24	4.8	4.8			
	58.0	237	1.1	24.47	4.7	4.7			
66.3	207	1.3	21.40	4.7	4.7				
74.9	183	1.3	18.95	4.6	4.6				
85.7	160	1.5	16.57	4.5	4.5				
91.3	151	1.6	15.55	4.4	4.4				
101.8	135	1.6	13.95	4.3	4.3				
124.7	110	1.7	11.38	4.1	4.1				
161.1	85	2.0	8.81	3.9	3.9				
21.2	655	1.0	44.32	10.0	4.0	D 352 - 100L/6A M 352 - 100L/6A			
23.5	591	1.1	40.00	10.0	4.0				
25.3	549	1.1	37.14	10.0	4.0				
27.2	510	1.1	34.50	10.0	4.0				
30.8	451	1.2	30.50	10.0	4.0				
33.4	416	1.2	28.13	10.0	4.0				
36.8	378	1.3	25.56	9.9	4.0				
39.9	348	1.4	23.57	9.8	3.9				
47.2	295	1.6	19.93	9.5	3.8				
57.8	240	2.0	16.25	9.1	3.6				
69.0	201	2.2	13.62	8.7	3.5				
78.4	177	2.3	11.99	8.5	3.4				
96.2	144	2.6	9.77	8.0	3.2				
114.8	121	2.9	8.19	7.7	3.1				



P_1 [kW]	n_2 [Min ⁻¹]	M_2 [Nm]	f_B	i_{ges}	$F_{R2} (M)$ [kN]	$F_{R2} (D,KS)$ [kN]	Typ / Type / Tipo / Type / Tipo	 Kg	 mm			
1.50	41.8	319	1.4	68.49	9.7	3.9	D/M 352 - 90S/2A D/M 352 - 80M/2C	37	80			
	51.2	260	1.8	55.83	9.3	3.7						
	52.6	253	1.8	54.36	9.3	3.7						
	61.1	218	2.1	46.79	9.0	3.6						
	64.5	206	2.2	44.32	8.9	3.6						
	71.5	186	2.4	40.00	8.7	3.5						
	77.0	173	2.6	37.14	8.5	3.4						
	82.9	161	2.6	34.50	8.4	3.3						
	93.8	142	2.7	30.50	8.1	3.2						
	101.7	131	2.8	28.13	7.9	3.2						
	111.9	119	3.1	25.56	7.7	3.1						
	121.3	110	3.3	23.57	7.6	3.0						
	143.5	93	3.8	19.93	7.2	2.9						
	20.7	663	0.9	68.49	10.0	4.0				D 352 - 90L/4A M 352 - 90L/4A	38	80
	25.4	541	1.1	55.83	10.0	4.0						
	26.1	526	1.1	54.36	10.0	4.0						
	30.3	453	1.3	46.79	10.0	4.0						
	32.0	429	1.4	44.32	10.0	4.0						
	35.5	387	1.5	40.00	9.9	4.0						
	38.2	360	1.7	37.14	9.8	3.9						
	41.2	334	1.6	34.50	9.7	3.9						
	46.6	295	1.7	30.50	9.5	3.8						
	50.5	272	1.8	28.13	9.3	3.7						
	55.6	248	1.9	25.56	9.1	3.6						
	60.2	228	2.1	23.57	9.0	3.6						
	71.2	193	2.4	19.93	8.6	3.4						
	87.4	157	2.9	16.25	8.2	3.3						
	104.3	132	3.2	13.62	7.8	3.1						
	118.5	116	3.4	11.99	7.6	3.0						
	145.3	95	3.8	9.77	7.2	2.9						
	35.2	370	1.2	81.25	10.0	4.0	D/M 353 - 90S/2A D/M 353 - 80M/2C	37	80			
	15.4	902	1.2	61.05	18.0	7.2	D 402 - 100L/6A M 402 - 100L/6A	54	82			
	17.6	790	1.3	53.44	18.0	7.2						
	19.0	732	1.4	49.50	18.0	7.2						
	22.2	626	1.7	42.38	18.0	7.2						
	23.8	583	1.8	39.44	18.0	7.2						
	27.4	508	2.1	34.36	18.0	7.1						
	30.1	462	2.3	31.28	18.0	7.0						
	33.3	417	2.3	28.22	18.0	6.8						
	35.0	397	2.4	26.83	18.0	6.7						
	39.8	349	2.4	23.60	18.0	6.4						
	43.2	322	2.6	21.75	18.0	6.3						
	47.5	293	2.8	19.80	18.0	6.1						
	55.3	251	3.2	16.99	18.0	5.8						
	61.0	228	3.5	15.42	18.0	5.7						
	46.8	284	2.7	61.05	18.0	6.1				D/M 402 - 90S/2A D/M 402 - 80M/2C	46	82
	53.5	249	3.1	53.44	18.0	5.8						
	57.8	231	3.3	49.50	18.0	5.7						
	67.5	197	3.8	42.38	18.0	5.4						
	72.5	184	4.1	39.44	18.0	5.3						
	23.3	591	1.7	61.05	18.0	7.2	D 402 - 90L/4A M 402 - 90L/4A	47	82			
	26.6	518	1.9	53.44	18.0	7.2						
	28.7	479	2.1	49.50	18.0	7.0						
	33.5	410	2.4	42.38	18.0	6.7						
	36.0	382	2.6	39.44	18.0	6.6						
	41.3	333	3.0	34.36	18.0	6.3						
	45.4	303	3.3	31.28	18.0	6.1						
	50.3	273	3.3	28.22	18.0	5.9						
	52.9	260	3.5	26.83	18.0	5.8						
	60.2	229	3.5	23.60	18.0	5.6						
	65.3	211	3.8	21.75	18.0	5.5						
	71.7	192	4.0	19.80	18.0	5.3						
	12.6	1078	1.0	74.45	18.0	7.2				D 403 - 100L/6A M 403 - 100L/6A	54	82
	13.9	981	1.1	67.77	18.0	7.2						



P_1 [kW]	n_2 [Min ⁻¹]	M_2 [Nm]	f_B	i_{ges}	F_{R2} (M) [kN]	F_{R2} (D,KS) [kN]	Typ / Type / Tipo / Type / Tipo	Kg	mm
1.50	18.0	724	1.0	158.93	18.0	7.2	D 403 - 80M/2C M 403 - 80M/2C	46	82
	22.2 24.4 31.1 38.4 42.2	587 535 419 339 309	1.3 1.4 1.8 2.2 2.5	128.86 117.30 91.83 74.45 67.77	18.0 18.0 18.0 18.0 18.0	7.2 7.2 6.8 6.4 6.2	D/M 403 - 90S/2A D/M 403 - 80M/2C	46	82
	15.5 19.1 21.0	871 706 643	1.1 1.4 1.6	91.83 74.45 67.77	18.0 18.0 18.0	7.2 7.2 7.2	D 403 - 90L/4A M 403 - 90L/4A	47	82
	14.1 16.1 17.3 20.3 21.7 24.9 27.4 29.5 32.0 36.3	988 865 803 686 641 557 508 471 434 383	1.7 1.9 1.7 2.4 2.1 2.8 2.9 3.3 3.6 4.1	66.83 58.50 54.31 46.39 43.33 37.70 34.36 31.86 29.36 25.89	22.0 22.0 22.0 22.0 22.0 22.0 22.0 22.0 22.0 22.0	9.0 9.0 9.0 9.0 9.0 9.0 8.9 8.7 8.5 8.2	D 502 - 100L/6A M 502 - 100L/6A	65	84
	42.8 52.7	311 253	3.9 3.9	66.83 54.31	22.0 22.0	7.7 7.3	D/M 502 - 90S/2A D/M 502 - 80M/2C	57	84
	21.2 24.3 26.1 30.6 32.8 37.7	647 567 526 449 420 365	2.5 2.8 2.5 3.6 3.1 4.1	66.83 58.50 54.31 46.39 43.33 37.70	22.0 22.0 22.0 22.0 22.0 22.0	9.0 9.0 9.0 8.5 8.4 8.0	D 502 - 90L/4A M 502 - 90L/4A	58	84
	8.5 9.4 11.5 12.6	1603 1455 1183 1078	1.0 1.2 1.4 1.6	110.73 100.51 81.69 74.45	22.0 22.0 22.0 22.0	9.0 9.0 9.0 9.0	D 503 - 100L/6A M 503 - 100L/6A	65	84
	12.8 14.1 16.4 20.2 22.2 25.8 28.5 35.0 38.4	1016 926 793 644 587 505 458 372 339	1.2 1.3 1.5 1.9 2.1 2.4 2.7 3.3 3.6	222.80 203.06 173.97 141.39 128.86 110.73 100.51 81.69 74.45	22.0 22.0 22.0 22.0 22.0 22.0 22.0 22.0 22.0	9.0 9.0 9.0 9.0 9.0 9.0 8.7 8.2 8.0	D/M 503 - 90S/2A D/M 503 - 80M/2C	57	84
	8.2 10.0 11.0 12.8 14.1 17.4 19.1	1650 1341 1222 1050 953 775 706	1.0 1.2 1.3 1.5 1.7 2.1 2.3	173.97 141.39 128.86 110.73 100.51 81.69 74.45	22.0 22.0 22.0 22.0 22.0 22.0 22.0	9.0 9.0 9.0 9.0 9.0 9.0 9.0	D 503 - 90L/4A M 503 - 90L/4A	58	84
	14.1 17.3 18.9	989 805 735	3.2 3.4 3.4	66.88 54.47 49.69	30.0 30.0 30.0	11.2 11.2 11.2	D 602 - 100L/6A M 602 - 100L/6A	99	86
	4.8 5.3 6.2 7.0 7.6 8.4 10.8 13.3	2813 2566 2186 1932 1780 1624 1256 1023	1.1 1.2 1.4 1.6 1.8 1.9 2.5 2.8	194.28 177.25 150.99 133.43 122.97 112.19 86.78 70.67	30.0 30.0 30.0 30.0 30.0 30.0 30.0 30.0	11.2 11.2 11.2 11.2 11.2 11.2 11.2 11.2	D 603 - 100L/6A M 603 - 100L/6A	99	86

P_1 [kW]	n_2 [Min ⁻¹]	M_2 [Nm]	f_B	i_{ges}	$F_{R2} (M)$ [kN]	$F_{R2} (D,KS)$ [kN]	Typ / Type / Tipo / Type / Tipo	 Kg	 mm
1.50	8.3	1566	1.5	343.64	30.0	11.2	D/M 603 - 90S/2A D/M 603 - 80M/2C	92	86
	9.5	1371	1.7	300.83	30.0	11.2			
	10.2	1276	1.8	279.86	30.0	11.2			
	12.0	1087	2.1	238.56	30.0	11.2			
	14.7	886	2.6	194.28	30.0	11.2			
	16.1	808	2.8	177.25	30.0	11.2			
	18.9	688	3.3	150.99	30.0	11.2			
	21.4	608	3.7	133.43	30.0	11.2			
	23.3	560	4.1	122.97	30.0	11.2			
	4.1	3259	0.9	343.64	30.0	11.2			
	4.7	2853	1.1	300.83	30.0	11.2			
	5.1	2654	1.1	279.86	30.0	11.2			
	6.0	2262	1.3	238.56	30.0	11.2			
	7.3	1842	1.6	194.28	30.0	11.2			
	8.0	1681	1.8	177.25	30.0	11.2			
	9.4	1432	2.1	150.99	30.0	11.2			
	10.6	1265	2.4	133.43	30.0	11.2			
	11.5	1166	2.6	122.97	30.0	11.2			
	12.7	1064	2.8	112.19	30.0	11.2			
1.85	83.0	206	1.0	11.38	4.3	4.3	D 302 - 100L/6 M 302 - 100L/6	41	78
	107.2	160	1.1	8.81	4.1	4.1			
	53.7	316	0.9	26.24	4.4	4.4	D 302 - 90L/4 M 302 - 90L/4	34	78
	65.9	257	1.1	21.40	4.4	4.4			
	74.4	228	1.1	18.95	4.3	4.3			
	85.1	199	1.3	16.57	4.2	4.2			
	90.7	187	1.3	15.55	4.2	4.2			
	101.1	168	1.3	13.95	4.1	4.1			
	123.9	137	1.5	11.38	4.0	4.0			
	160.0	106	1.7	8.81	3.8	3.8			
	25.4	674	0.9	37.14	9.6	3.8			
	31.0	553	0.9	30.50	9.5	3.8			
	33.6	510	1.0	28.13	9.4	3.8			
	37.0	464	1.1	25.56	9.3	3.7			
	40.1	427	1.2	23.57	9.2	3.7			
	47.4	361	1.3	19.93	9.0	3.6			
	58.2	295	1.6	16.25	8.7	3.5			
	69.4	247	1.8	13.62	8.4	3.4			
	78.8	217	1.9	11.99	8.2	3.3			
	96.7	177	2.1	9.77	7.8	3.1			
	115.4	149	2.3	8.19	7.5	3.0			
	25.3	672	0.9	55.83	9.6	3.8	D 352 - 90L/4 M 352 - 90L/4	38	80
	25.9	654	0.9	54.36	9.6	3.8			
	30.1	563	1.1	46.79	9.5	3.8			
	31.8	533	1.1	44.32	9.5	3.8			
	35.3	481	1.2	40.00	9.4	3.7			
	38.0	447	1.3	37.14	9.3	3.7			
	40.9	415	1.3	34.50	9.2	3.7			
	46.2	367	1.4	30.50	9.0	3.6			
	50.1	338	1.4	28.13	8.9	3.6			
	55.2	307	1.6	25.56	8.7	3.5			
	59.8	284	1.7	23.57	8.6	3.4			
	70.7	240	1.9	19.93	8.3	3.3			
86.8	195	2.3	16.25	8.0	3.2				
103.5	164	2.6	13.62	7.6	3.1				
117.6	144	2.7	11.99	7.4	3.0				
144.3	118	3.1	9.77	7.0	2.8				
172.2	99	3.3	8.19	6.7	2.7				



P_1 [kW]	n_2 [Min ⁻¹]	M_2 [Nm]	f_B	i_{ges}	$F_{R2} (M)$ [kN]	$F_{R2} (D,KS)$ [kN]	Typ / Type / Tipo / Type / Tipo	Kg	mm				
1.85	17.7	969	1.1	53.44	18.0	7.2	D 402 - 100L/6 M 402 - 100L/6	55	82				
	19.1	898	1.2	49.50	18.0	7.2							
	22.3	769	1.4	42.38	18.0	7.2							
	24.0	715	1.5	39.44	18.0	7.2							
	27.5	623	1.7	34.36	18.0	7.0							
	30.2	567	1.9	31.28	18.0	6.9							
	33.5	512	1.8	28.22	18.0	6.7							
	35.2	486	1.9	26.83	18.0	6.6							
	40.0	428	2.0	23.60	18.0	6.3							
	43.4	394	2.1	21.75	18.0	6.2							
	47.7	359	2.3	19.80	18.0	6.0							
	55.6	308	2.6	16.99	18.0	5.8							
	61.3	280	2.9	15.42	18.0	5.6							
	75.6	227	3.5	12.50	18.0	5.3							
	83.1	206	3.6	11.38	17.9	5.1							
97.3	176	3.9	9.71	17.1	4.9								
	23.1	734	1.4	61.05	18.0	7.2	D 402 - 90L/4 M 402 - 90L/4	47	82				
	26.4	643	1.6	53.44	18.0	7.0							
	28.5	595	1.7	49.50	18.0	6.9							
	33.3	510	2.0	42.38	18.0	6.6							
	35.7	474	2.1	39.44	18.0	6.5							
	41.0	413	2.4	34.36	18.0	6.2							
	45.1	376	2.7	31.28	18.0	6.1							
	50.0	339	2.7	28.22	18.0	5.9							
	52.6	323	2.8	26.83	18.0	5.8							
	59.7	284	2.8	23.60	18.0	5.6							
	64.8	262	3.1	21.75	18.0	5.4							
	71.2	238	3.2	19.80	18.0	5.3							
	83.0	204	3.8	16.99	17.7	5.0							
		15.4	1082	0.9	91.83	18.0				7.2	D 403 - 90L/4 M 403 - 90L/4	47	82
		18.9	877	1.1	74.45	18.0				7.2			
20.8		798	1.3	67.77	18.0	7.2							
	14.1	1212	1.4	66.83	22.0	9.0	D 502 - 100L/6 M 502 - 100L/6	66	84				
	16.2	1061	1.6	58.50	22.0	9.0							
	17.4	985	1.4	54.31	22.0	9.0							
	20.4	841	2.0	46.39	22.0	9.0							
	21.8	786	1.7	43.33	22.0	9.0							
	25.1	684	2.3	37.70	22.0	9.0							
	27.5	623	2.4	34.36	22.0	8.8							
	29.7	578	2.7	31.86	22.0	8.6							
	32.2	532	3.0	29.36	22.0	8.4							
	36.5	470	3.4	25.89	22.0	8.1							
	39.6	433	3.6	23.86	22.0	7.9							
	43.4	394	3.7	21.75	22.0	7.7							
		21.1	804	2.0	66.83	22.0				9.0	D 502 - 90L/4 M 502 - 90L/4	58	84
		24.1	704	2.3	58.50	22.0				9.0			
		26.0	653	2.0	54.31	22.0				8.9			
30.4		558	2.9	46.39	22.0	8.5							
32.5		521	2.5	43.33	22.0	8.3							
37.4		454	3.3	37.70	22.0	8.0							
41.0		413	3.4	34.36	22.0	7.7							
44.3		383	3.9	31.86	22.0	7.6							
		9.4	1785	0.9	100.51	22.0	9.0	D 503 - 100L/6 M 503 - 100L/6	66	84			
	11.6	1451	1.2	81.69	22.0	9.0							
	12.7	1322	1.3	74.45	22.0	9.0							
	10.0	1665	1.0	141.39	22.0	9.0	D 503 - 90L/4 M 503 - 90L/4	58	84				
	10.9	1518	1.1	128.86	22.0	9.0							
	12.7	1304	1.2	110.73	22.0	9.0							
	14.0	1184	1.4	100.51	22.0	9.0							
	17.3	962	1.7	81.69	22.0	9.0							
	18.9	877	1.8	74.45	22.0	9.0							
	14.1	1213	2.6	66.88	30.0	11.2	D 602 - 100L/6 M 602 - 100L/6	101	86				
	17.4	988	2.8	54.47	30.0	11.2							
	19.0	901	2.8	49.69	30.0	11.2							
	21.4	801	3.9	44.19	30.0	11.2							
	21.1	804	3.7	66.88	30.0	11.2	D 602 - 90L/4 M 602 - 90L/4	93	86				
	25.9	655	4.0	54.47	30.0	11.2							



P ₁ [kW]	n ₂ [Min ⁻¹]	M ₂ [Nm]	f _B	i _{ges}	F _{R2} (M) [kN]	F _{R2} (D,KS) [kN]	Typ / Type / Tipo / Type / Tipo	 Kg	 mm
1.85	5.3	3148	1.0	177.25	30.0	11.2	D 603 - 100L/6 M 603 - 100L/6	101	86
	6.3	2682	1.2	150.99	30.0	11.2			
	7.1	2370	1.3	133.43	30.0	11.2			
	7.7	2184	1.4	122.97	30.0	11.2			
	8.4	1993	1.6	112.19	30.0	11.2			
	10.9	1541	2.0	86.78	30.0	11.2			
	13.4	1255	2.3	70.67	30.0	11.2			
	5.0	3296	0.9	279.86	30.0	11.2	D 603 - 90L/4 M 603 - 90L/4	93	86
	5.9	2810	1.1	238.56	30.0	11.2			
	7.3	2288	1.3	194.28	30.0	11.2			
	8.0	2088	1.4	177.25	30.0	11.2			
	9.3	1778	1.7	150.99	30.0	11.2			
	10.6	1572	1.9	133.43	30.0	11.2			
	11.5	1448	2.1	122.97	30.0	11.2			
12.6	1321	2.3	112.19	30.0	11.2				
2.20	85.1	237	1.0	16.57	4.0	4.0	D 302 - 100L/4A M 302 - 100L/4A	41	78
	90.7	222	1.1	15.55	4.0	4.0			
	101.1	200	1.1	13.95	3.9	3.9			
	123.9	163	1.2	11.38	3.8	3.8			
	160.0	126	1.3	8.81	3.6	3.6			
	93.9	208	1.1	30.46	4.0	4.0	D 302 - 90L/2A M 302 - 90L/2A	35	78
	101.2	193	1.1	28.26	4.0	4.0			
	109.0	179	1.2	26.24	3.9	3.9			
	116.9	167	1.2	24.47	3.9	3.9			
	133.6	146	1.4	21.40	3.8	3.8			
	150.9	129	1.4	18.95	3.7	3.7			
	172.6	113	1.6	16.57	3.6	3.6			
	184.0	106	1.7	15.55	3.6	3.6			
	205.0	95	1.7	13.95	3.5	3.5			
	251.3	78	1.9	11.38	3.3	3.3			
	324.5	60	2.1	8.81	3.1	3.1			
	31.8	634	0.9	44.32	8.8	3.5	D 352 - 100L/4A M 352 - 100L/4A	45	80
	35.3	572	1.0	40.00	8.8	3.5			
	38.0	531	1.1	37.14	8.7	3.5			
	40.9	494	1.2	34.50	8.7	3.5			
	46.2	436	1.2	30.50	8.6	3.4			
	50.1	402	1.2	28.13	8.5	3.4			
	55.2	366	1.3	25.56	8.4	3.4			
	59.8	337	1.4	23.57	8.3	3.3			
	70.7	285	1.6	19.93	8.0	3.2			
	86.8	232	1.9	16.25	7.7	3.1			
	103.5	195	2.2	13.62	7.4	3.0			
	117.6	171	2.3	11.99	7.2	2.9			
	144.3	140	2.6	9.77	6.9	2.8			
	172.2	117	2.8	8.19	6.6	2.6			
	47.4	430	1.1	19.93	8.6	3.4	D 352 - 112M/6A M 352 - 112M/6A	54	80
	58.2	350	1.3	16.25	8.3	3.3			
	69.4	294	1.5	13.62	8.1	3.2			
	78.8	259	1.6	11.99	7.9	3.2			
	96.7	211	1.8	9.77	7.6	3.0			
	115.4	177	2.0	8.19	7.3	2.9			
	51.2	381	1.2	55.83	8.6	3.4	D 352 - 90L/2A M 352 - 90L/2A	39	80
	52.6	371	1.2	54.36	8.5	3.4			
	61.1	320	1.4	46.79	8.3	3.3			
	64.5	303	1.5	44.32	8.3	3.3			
	71.5	273	1.7	40.00	8.1	3.2			
	77.0	254	1.8	37.14	8.0	3.2			
82.9	236	1.9	34.50	7.9	3.2				
93.8	208	2.0	30.50	7.7	3.1				
101.7	192	2.0	28.13	7.5	3.0				
111.9	175	2.1	25.56	7.4	3.0				
121.3	161	2.2	23.57	7.2	2.9				
143.5	136	2.6	19.93	7.0	2.8				
176.0	111	3.1	16.25	6.6	2.6				
210.0	93	3.4	13.62	6.3	2.5				
238.6	82	3.6	11.99	6.1	2.4				



P_1 [kW]	n_2 [Min ⁻¹]	M_2 [Nm]	f_B	i_{ges}	$F_{R2} (M)$ [kN]	$F_{R2} (D,KS)$ [kN]	Typ / Type / Tipo / Type / Tipo	 Kg	 mm
2.20	23.1	873	1.1	61.05	18.0	7.2	D 402 - 100L/4A M 402 - 100L/4A	55	82
	26.4	765	1.3	53.44	18.0	6.9			
	28.5	708	1.4	49.50	18.0	6.8			
	33.3	606	1.6	42.38	18.0	6.5			
	35.7	564	1.8	39.44	18.0	6.4			
	41.0	492	2.0	34.36	18.0	6.1			
	45.1	447	2.2	31.28	18.0	6.0			
	50.0	404	2.2	28.22	18.0	5.8			
	52.6	384	2.3	26.83	18.0	5.7			
	59.7	338	2.4	23.60	18.0	5.5			
64.8	311	2.6	21.75	18.0	5.4				
71.2	283	2.7	19.80	18.0	5.2				
83.0	243	3.2	16.99	17.5	5.0				
91.5	221	3.5	15.42	17.0	4.9				
	22.3	914	1.1	42.38	18.0	7.2	D 402 - 112M/6A M 402 - 112M/6A	63	82
	24.0	851	1.2	39.44	18.0	7.2			
	27.5	741	1.4	34.36	18.0	6.9			
	30.2	675	1.6	31.28	18.0	6.7			
	33.5	609	1.6	28.22	18.0	6.6			
	35.2	579	1.6	26.83	18.0	6.5			
	40.0	509	1.7	23.60	18.0	6.3			
	43.4	469	1.8	21.75	18.0	6.1			
	47.7	427	1.9	19.80	18.0	6.0			
	55.6	366	2.2	16.99	18.0	5.7			
	61.3	332	2.4	15.42	18.0	5.5			
	75.6	270	2.9	12.50	18.0	5.2			
	83.1	245	3.0	11.38	17.8	5.1			
	97.3	209	3.3	9.71	17.0	4.8			
	120.0	170	3.7	7.88	15.9	4.5			
131.8	155	3.7	7.17	15.5	4.4				
	46.8	417	1.8	61.05	18.0	6.0	D 402 - 90L/2A M 402 - 90L/2A	48	82
	53.5	365	2.1	53.44	18.0	5.7			
	57.8	338	2.2	49.50	18.0	5.6			
	67.5	290	2.6	42.38	18.0	5.4			
	72.5	269	2.8	39.44	18.0	5.2			
	83.2	235	3.2	34.36	17.6	5.0			
	91.4	214	3.6	31.28	17.1	4.9			
	101.4	193	3.5	28.22	16.6	4.7			
	106.6	183	3.7	26.83	16.4	4.7			
	121.2	161	3.8	23.60	15.7	4.5			
131.5	149	4.1	21.75	15.3	4.4				
	18.9	1043	1.0	74.45	18.0	7.2	D 403 - 100L/4A M 403 - 100L/4A	54	82
	20.8	949	1.1	67.77	18.0	7.2			
	31.1	614	1.2	91.83	18.0	6.6	D 403 - 90L/2A M 403 - 90L/2A	48	82
	38.4	498	1.5	74.45	18.0	6.3			
	42.2	453	1.7	67.77	18.0	6.1			
	21.1	956	1.7	66.83	22.0	9.0	D 502 - 100L/4A M 502 - 100L/4A	66	84
	24.1	837	1.9	58.50	22.0	9.0			
	26.0	777	1.7	54.31	22.0	8.8			
	30.4	664	2.4	46.39	22.0	8.4			
	32.5	620	2.1	43.33	22.0	8.2			
	37.4	539	2.8	37.70	22.0	7.9			
	41.0	492	2.8	34.36	22.0	7.7			
	44.3	456	3.3	31.86	22.0	7.5			
	48.0	420	3.6	29.36	22.0	7.3			
	54.5	370	4.0	25.89	22.0	7.1			



P_1 [kW]	n_2 [Min ⁻¹]	M_2 [Nm]	f_B	i_{ges}	$F_{R2} (M)$ [kN]	$F_{R2} (D,KS)$ [kN]	Typ / Type / Tipo / Type / Tipo	 Kg	 mm			
2.20	14.1	1441	1.2	66.83	22.0	9.0	D 502 - 112M/6A M 502 - 112M/6A	74	84			
	16.2	1262	1.3	58.50	22.0	9.0						
	17.4	1171	1.2	54.31	22.0	9.0						
	20.4	1000	1.7	46.39	22.0	9.0						
	21.8	935	1.5	43.33	22.0	9.0						
	25.1	813	1.9	37.70	22.0	9.0						
	27.5	741	2.0	34.36	22.0	8.7						
	29.7	687	2.3	31.86	22.0	8.5						
	32.2	633	2.5	29.36	22.0	8.3						
	36.5	558	2.8	25.89	22.0	8.0						
	39.6	515	3.1	23.86	22.0	7.9						
	43.4	469	3.1	21.75	22.0	7.6						
	50.6	403	3.7	18.67	22.0	7.3						
	56.0	364	3.8	16.88	22.0	7.1						
	68.9	296	4.3	13.72	22.0	6.7						
	75.6	270	3.9	12.50	22.0	6.5						
		42.8	457	2.7	66.83	22.0	7.6	D 502 - 90L/2A M 502 - 90L/2A	59	84		
		48.9	400	3.0	58.50	22.0	7.3					
		52.7	371	2.7	54.31	22.0	7.2					
		61.7	317	3.8	46.39	22.0	6.8					
		66.0	296	3.3	43.33	22.0	6.7					
		12.7	1551	1.0	110.73	22.0	9.0	D 503 - 100L/4A M 503 - 100L/4A	66	84		
		14.0	1408	1.1	100.51	22.0	9.0					
		17.3	1144	1.4	81.69	22.0	9.0					
		18.9	1043	1.5	74.45	22.0	9.0					
		16.4	1163	1.0	173.97	22.0	9.0	D 503 - 90L/2A M 503 - 90L/2A	59	84		
		20.2	945	1.3	141.39	22.0	9.0					
		22.2	861	1.4	128.86	22.0	9.0					
		25.8	740	1.6	110.73	22.0	8.8					
		28.5	672	1.8	100.51	22.0	8.6					
		35.0	546	2.2	81.69	22.0	8.1					
		38.4	498	2.4	74.45	22.0	7.8					
		21.1	957	3.1	66.88	30.0	11.2	D 602 - 100L/4A M 602 - 100L/4A	101	86		
		25.9	779	3.3	54.47	30.0	11.2					
		28.4	711	3.4	49.69	30.0	11.2					
		14.1	1442	2.2	66.88	30.0	11.2	D 602 - 112M/6A M 602 - 112M/6A	108	86		
		17.4	1175	2.3	54.47	30.0	11.2					
		19.0	1072	2.4	49.69	30.0	11.2					
		21.4	953	3.3	44.19	30.0	11.2					
		22.7	898	3.5	41.65	30.0	11.2					
		26.5	770	4.1	35.72	30.0	11.2					
		7.3	2721	1.1	194.28	30.0	11.2	D 603 - 100L/4A M 603 - 100L/4A	101	86		
		8.0	2483	1.2	177.25	30.0	11.2					
		9.3	2115	1.4	150.99	30.0	11.2					
		10.6	1869	1.6	133.43	30.0	11.2					
		11.5	1722	1.7	122.97	30.0	11.2					
		12.6	1571	1.9	112.19	30.0	11.2					
	16.2	1215	2.5	86.78	30.0	11.2						
	20.0	990	2.7	70.67	30.0	11.2						
	7.7	2597	1.2	122.97	30.0	11.2	D 603 - 112M/6A M 603 - 112M/6A	108	86			
	8.4	2370	1.3	112.19	30.0	11.2						
	10.9	1833	1.7	86.78	30.0	11.2						
	13.4	1493	1.9	70.67	30.0	11.2						
	9.5	2011	1.1	300.83	30.0	11.2	D 603 - 90L/2A M 603 - 90L/2A	94	86			
	10.2	1871	1.2	279.86	30.0	11.2						
	12.0	1595	1.4	238.56	30.0	11.2						
	14.7	1299	1.8	194.28	30.0	11.2						
	16.1	1185	1.9	177.25	30.0	11.2						
	18.9	1009	2.3	150.99	30.0	11.2						
	21.4	892	2.6	133.43	30.0	11.2						
	23.3	822	2.8	122.97	30.0	11.2						
	25.5	750	3.0	112.19	30.0	11.2						



P ₁ [kW]	n ₂ [Min ⁻¹]	M ₂ [Nm]	f _B	i _{ges}	F _{R2} (M) [kN]	F _{R2} (D,KS) [kN]	Typ / Type / Tipo / Type / Tipo	Kg	mm
3.00	174.4	153	1.2	16.57	3.4	3.4	D 302 - 100L/2A M 302 - 100L/2A	41	78
	185.9	143	1.3	15.55	3.4	3.4			
	207.1	129	1.2	13.95	3.3	3.3			
	253.9	105	1.4	11.38	3.2	3.2			
	327.9	81	1.6	8.81	3.0	3.0			
	160.0	172	1.0	8.81	3.4	3.4			
	65.2	409	1.1	44.32	7.6	3.0	D 352 - 100L/2A M 352 - 100L/2A	45	80
	72.3	369	1.2	40.00	7.5	3.0			
	77.8	342	1.3	37.14	7.4	3.0			
	83.8	318	1.4	34.50	7.3	2.9			
	94.8	281	1.5	30.50	7.2	2.9			
	102.8	259	1.5	28.13	7.1	2.8			
	113.1	236	1.5	25.56	7.0	2.8			
	122.6	217	1.6	23.57	6.9	2.8			
	145.0	184	1.9	19.93	6.6	2.7			
	177.8	150	2.3	16.25	6.4	2.5			
	212.2	126	2.5	13.62	6.1	2.4			
	241.1	111	2.7	11.99	5.9	2.4			
	295.7	90	3.0	9.77	5.6	2.2			
	352.8	76	3.3	8.19	5.3	2.1			
	55.2	499	1.0	25.56	7.5	3.0	D 352 - 100L/4B M 352 - 100L/4B	48	80
	59.8	460	1.0	23.57	7.5	3.0			
	70.7	389	1.2	19.93	7.4	3.0			
	86.8	317	1.4	16.25	7.2	2.9			
	103.5	266	1.6	13.62	7.0	2.8			
	117.6	234	1.7	11.99	6.8	2.7			
	144.3	191	1.9	9.77	6.6	2.6			
	172.2	160	2.1	8.19	6.3	2.5			
58.8	473	1.0	16.25	7.5	3.0	D 352 - 112M/6 M 352 - 112M/6	69	80	
70.1	396	1.1	13.62	7.4	3.0				
79.7	349	1.2	11.99	7.3	2.9				
97.7	284	1.3	9.77	7.1	2.8				
116.6	238	1.5	8.19	6.9	2.8				
47.3	563	1.4	61.05	18.0	5.8	D 402 - 100L/2A M 402 - 100L/2A	55	82	
54.1	493	1.5	53.44	18.0	5.6				
58.4	456	1.7	49.50	18.0	5.5				
68.2	391	1.9	42.38	18.0	5.3				
73.3	364	2.1	39.44	18.0	5.2				
84.1	317	2.4	34.36	17.3	5.0				
92.4	288	2.6	31.28	16.9	4.8				
102.4	260	2.6	28.22	16.4	4.7				
107.7	247	2.8	26.83	16.1	4.6				
122.5	218	2.8	23.60	15.5	4.4				
132.9	201	3.0	21.75	15.2	4.3				
146.0	183	3.2	19.80	14.7	4.2				
170.1	157	3.7	16.99	14.1	4.0				
187.5	142	4.1	15.42	13.7	3.9				
26.4	1043	1.0	53.44	18.0	6.7	D 402 - 100L/4B M 402 - 100L/4B	58	82	
28.5	966	1.0	49.50	18.0	6.5				
33.3	827	1.2	42.38	18.0	6.3				
35.7	769	1.3	39.44	18.0	6.2				
41.0	670	1.5	34.36	18.0	6.0				
45.1	610	1.6	31.28	18.0	5.8				
50.0	550	1.6	28.22	18.0	5.7				
52.6	523	1.7	26.83	18.0	5.6				
59.7	460	1.7	23.60	18.0	5.4				
64.8	424	1.9	21.75	18.0	5.3				
71.2	386	2.0	19.80	18.0	5.1				
83.0	331	2.3	16.99	17.2	4.9				
91.5	301	2.6	15.42	16.8	4.8				
112.8	244	3.1	12.50	15.8	4.5				
123.9	222	3.2	11.38	15.3	4.4				
145.2	189	3.4	9.71	14.7	4.2				
179.0	154	3.9	7.88	13.8	3.9				
196.7	140	3.9	7.17	13.4	3.8				



P ₁ [kW]	n ₂ [Min ⁻¹]	M ₂ [Nm]	f _B	i _{ges}	F _{R2} (M) [kN]	F _{R2} (D,KS) [kN]	Typ / Type / Tipo / Type / Tipo	 Kg	 mm			
3.00	27.8	1000	1.1	34.36	18.0	6.6	D 402 - 112M/6 M 402 - 112M/6	78	82			
	30.5	910	1.2	31.28	18.0	6.5						
	33.8	821	1.2	28.22	18.0	6.3						
	35.6	781	1.2	26.83	18.0	6.3	D/M 402 - 132S/6B D/M 402 - 112M/6	78	82			
	40.5	687	1.2	23.60	18.0	6.1						
	43.9	633	1.3	21.75	18.0	5.9						
	48.2	576	1.4	19.80	18.0	5.8						
	56.2	494	1.6	16.99	18.0	5.6						
	61.9	449	1.8	15.42	18.0	5.4						
	76.4	364	2.2	12.50	17.9	5.1						
	83.9	331	2.2	11.38	17.4	5.0						
	98.3	283	2.4	9.71	16.7	4.8						
	121.3	229	2.7	7.88	15.7	4.5						
	133.2	209	2.8	7.17	15.3	4.4						
	38.8	672	1.1	74.45	18.0	6.1	D 403 - 100L/2A M 403 - 100L/2A	55	82			
	42.6	611	1.2	67.77	18.0	6.0						
	43.2	616	2.0	66.83	22.0	7.5	D 502 - 100L/2A M 502 - 100L/2A	66	84			
	49.4	539	2.3	58.50	22.0	7.2						
	53.2	501	2.0	54.31	22.0	7.1						
	62.3	428	2.8	46.39	22.0	6.7						
	66.7	400	2.5	43.33	22.0	6.6						
	76.6	348	3.3	37.70	22.0	6.3						
	84.1	317	3.4	34.36	21.6	6.2						
	90.7	294	3.9	31.86	21.1	6.0						
	98.4	271	4.2	29.36	20.6	5.9						
	21.1	1304	1.2	66.83	22.0	9.0				D 502 - 100L/4B M 502 - 100L/4B	69	84
	24.1	1141	1.4	58.50	22.0	8.7						
	26.0	1059	1.2	54.31	22.0	8.6						
	30.4	905	1.8	46.39	22.0	8.2						
	32.5	845	1.5	43.33	22.0	8.0						
	37.4	735	2.0	37.70	22.0	7.7						
	41.0	670	2.1	34.36	22.0	7.5						
	44.3	621	2.4	31.86	22.0	7.4						
	48.0	573	2.6	29.36	22.0	7.2						
	54.5	505	3.0	25.89	22.0	7.0						
	59.1	466	3.2	23.86	22.0	6.8						
	64.8	424	3.3	21.75	22.0	6.6						
	75.5	364	3.8	18.67	22.0	6.3						
	83.6	329	3.9	16.88	21.4	6.1						
	112.8	244	4.1	12.50	19.6	5.6						
	16.3	1702	1.0	58.50	22.0	9.0	D 502 - 112M/6 M 502 - 112M/6	89	84			
	22.0	1261	1.1	43.33	22.0	9.0						
20.6	1350	1.2	46.39	22.0	9.0	D/M 502 - 132S/6B D/M 502 - 112M/6	89	84				
25.3	1097	1.2	37.70	22.0	8.7							
27.8	1000	1.6	34.36	22.0	8.5							
30.0	927	1.6	31.86	22.0	8.3							
32.5	854	1.8	29.36	22.0	8.2							
36.9	754	2.1	25.89	22.0	7.9							
40.0	694	2.3	23.86	22.0	7.7							
43.9	633	2.5	21.75	22.0	7.5							
51.2	543	2.7	18.67	22.0	7.2							
56.6	491	3.0	16.88	22.0	7.0							
69.6	399	3.4	13.72	22.0	6.6							
76.4	364	2.9	12.50	22.0	6.4							
89.8	309	3.2	10.63	21.3	6.1							
110.5	251	3.8	8.64	20.0	5.7							
121.3	229	3.9	7.88	19.5	5.6							
26.1	999	1.2	110.73	22.0	8.6	D 503 - 100L/2A M 503 - 100L/2A	66	84				
28.8	907	1.3	100.51	22.0	8.4							
35.4	737	1.6	81.69	22.0	7.9							
38.8	672	1.8	74.45	22.0	7.7							
17.3	1560	1.0	81.69	22.0	9.0	D 503 - 100L/4B M 503 - 100L/4B	69	84				
18.9	1422	1.1	74.45	22.0	9.0							
43.2	617	3.7	66.88	30.0	10.6	D 602 - 100L/2A M 602 - 100L/2A	101	86				
53.1	502	3.9	54.47	30.0	10.0							
58.2	458	4.0	49.69	30.0	9.7							

P ₁ [kW]	n ₂ [Min ⁻¹]	M ₂ [Nm]	f _B	i _{ges}	F _{R2} (M) [kN]	F _{R2} (D,KS) [kN]	Typ / Type / Tipo / Type / Tipo	 Kg	 mm
3.00	21.1	1305	2.3	66.88	30.0	11.2	D 602 - 100L/4B M 602 - 100L/4B	104	86
	25.9	1062	2.4	54.47	30.0	11.2			
	28.4	969	2.5	49.69	30.0	11.2			
	31.9	862	3.5	44.19	30.0	11.2			
	33.9	813	3.7	41.65	30.0	11.2			
	14.3	1946	1.6	66.88	30.0	11.2	D/M 602 - 132S/6B D/M 602 - 112M/6	124	86
	17.5	1585	1.7	54.47	30.0	11.2			
	19.2	1446	1.7	49.69	30.0	11.2			
	21.6	1286	2.4	44.19	30.0	11.2			
	22.9	1212	2.6	41.65	30.0	11.2			
	26.7	1039	3.0	35.72	30.0	11.2			
	28.2	987	3.2	33.92	30.0	11.2			
	30.9	901	3.5	30.95	30.0	11.2			
	32.9	845	3.7	29.04	30.0	11.2			
	36.0	772	4.1	26.54	30.0	11.2			
	14.9	1753	1.3	194.28	30.0	10.9	D 603 - 100L/2A M 603 - 100L/2A	101	86
	16.3	1599	1.4	177.25	30.0	11.2			
	19.1	1362	1.7	150.99	30.0	11.2			
	21.7	1204	1.9	133.43	30.0	11.2			
	23.5	1109	2.1	122.97	30.0	11.2			
	25.8	1012	2.3	112.19	30.0	11.2			
	33.3	783	2.9	86.78	30.0	11.2			
	40.9	638	3.2	70.67	30.0	11.2			
	9.3	2884	1.0	150.99	30.0	11.2	D 603 - 100L/4B M 603 - 100L/4B	104	86
	10.6	2548	1.2	133.43	30.0	11.2			
	11.5	2349	1.3	122.97	30.0	11.2			
	12.6	2143	1.4	112.19	30.0	11.2			
	16.2	1657	1.8	86.78	30.0	11.2			
20.0	1350	2.0	70.67	30.0	11.2				
8.5	3197	1.0	112.19	30.0	11.2	D 603 - 112M/6 M 603 - 112M/6	124	86	
11.0	2473	1.3	86.78	30.0	11.2	D/M 603 - 132S/6B D/M 603 - 112M/6	124	86	
13.5	2014	1.4	70.67	30.0	11.2				
4.00	253.9	140	1.0	11.38	3.0	3.0	D 302 - 100L/2C M 302 - 100L/2C	50	78
	327.9	108	1.2	8.81	2.8	2.8			
	102.8	346	1.1	28.13	6.6	2.6	D 352 - 100L/2C M 352 - 100L/2C	54	80
	113.1	314	1.2	25.56	6.5	2.6			
	122.6	290	1.2	23.57	6.4	2.6			
	145.0	245	1.4	19.93	6.3	2.5	D/M 352 - 112M/2A D/M 352 - 100L/2C	54	80
	177.8	200	1.7	16.25	6.0	2.4			
	212.2	167	1.9	13.62	5.8	2.3			
	241.1	147	2.0	11.99	5.7	2.3			
	295.7	120	2.3	9.77	5.4	2.2			
	352.8	101	2.5	8.19	5.2	2.1			
	71.7	511	0.9	19.93	6.6	2.6	D 352 - 112M/4B M 352 - 112M/4B	56	80
	88.0	417	1.1	16.25	6.5	2.6			
	105.0	349	1.2	13.62	6.4	2.6			
119.3	307	1.3	11.99	6.4	2.5				
146.3	251	1.4	9.77	6.2	2.5				
174.6	210	1.6	8.19	6.0	2.4				
54.1	657	1.2	53.44	18.0	5.4	D 402 - 100L/2C M 402 - 100L/2C			
58.4	608	1.2	49.50	18.0	5.3				



P_1 [kW]	n_2 [Min ⁻¹]	M_2 [Nm]	f_B	i_{ges}	Fr2 D [kN]	Fr2 C-L [kN]	Typ / Type / Tipo / Type / Tipo	 Kg ~	 mm			
4.00	68.2	521	1.5	42.38	17.9	5.1	D/M 402 - 112M/2A D/M 402 - 100L/2C	63	82			
	73.3	485	1.6	39.44	17.6	5.0						
	84.1	422	1.8	34.36	17.0	4.8						
	92.4	385	2.0	31.28	16.5	4.7						
	102.4	347	2.0	28.22	16.1	4.6						
	107.7	330	2.1	26.83	15.8	4.5						
	122.5	290	2.1	23.60	15.3	4.4						
	132.9	267	2.3	21.75	14.9	4.3						
	146.0	243	2.4	19.80	14.5	4.2						
	170.1	209	2.8	16.99	13.9	4.0						
	187.5	190	3.1	15.42	13.5	3.9						
	231.2	154	3.7	12.50	12.7	3.6						
	254.0	140	3.8	11.38	12.3	3.5						
	297.6	119	4.1	9.71	11.8	3.4						
	33.7	1087	0.9	42.38	18.0	6.0				D 402 - 112M/4B M 402 - 112M/4B	65	82
	36.3	1012	1.0	39.44	18.0	5.9						
	41.6	881	1.1	34.36	18.0	5.8						
	45.7	802	1.2	31.28	18.0	5.6						
	50.7	724	1.2	28.22	18.0	5.5						
	53.3	688	1.3	26.83	18.0	5.4						
	60.6	605	1.3	23.60	18.0	5.3						
	65.7	558	1.4	21.75	18.0	5.1						
	72.2	508	1.5	19.80	17.6	5.0						
	84.2	436	1.8	16.99	16.9	4.8						
	92.8	395	1.9	15.42	16.4	4.7						
	114.4	321	2.3	12.50	15.5	4.4						
	125.7	292	2.4	11.38	15.1	4.3						
	147.2	249	2.6	9.71	14.4	4.1						
	181.6	202	3.0	7.88	13.6	3.9						
	199.5	184	3.0	7.17	13.2	3.8						
	44.1	840	1.0	21.75	18.0	5.7	D 402 - 132M/6A M 402 - 132M/6A	85	82			
	48.5	764	1.1	19.80	18.0	5.6						
	56.5	656	1.2	16.99	18.0	5.4						
	62.3	595	1.4	15.42	18.0	5.3						
	76.8	482	1.6	12.50	17.5	5.0						
	84.4	439	1.7	11.38	17.1	4.9						
98.8	375	1.8	9.71	16.4	4.7							
121.9	304	2.1	7.88	15.4	4.4							
133.9	277	2.1	7.17	15.0	4.3							
43.2	821	1.5	66.83	22.0	7.3	D/M 502 - 112M/2A D/M 502 - 100L/2C				74	84	
49.4	719	1.7	58.50	22.0	7.1							
53.2	668	1.5	54.31	22.0	6.9							
62.3	570	2.1	46.39	22.0	6.6							
66.7	533	1.9	43.33	22.0	6.5							
76.6	463	2.5	37.70	21.9	6.2							
84.1	422	2.5	34.36	21.3	6.1							
90.7	392	2.9	31.86	20.8	5.9							
98.4	361	3.2	29.36	20.3	5.8							
111.6	318	3.6	25.89	19.6	5.6							
121.1	293	3.9	23.86	19.1	5.5							
132.9	267	4.0	21.75	18.6	5.3							
21.4	1714	0.9	66.83	22.0	8.7		D 502 - 112M/4B M 502 - 112M/4B	76	84			
24.4	1500	1.1	58.50	22.0	8.4							
26.3	1393	0.9	54.31	22.0	8.3							
30.8	1190	1.3	46.39	22.0	8.0							
33.0	1111	1.2	43.33	22.0	7.8							
37.9	967	1.6	37.70	22.0	7.6							
41.6	881	1.6	34.36	22.0	7.4							
44.9	817	1.8	31.86	22.0	7.2							
48.7	753	2.0	29.36	22.0	7.1							
55.2	664	2.3	25.89	22.0	6.8							
59.9	612	2.5	23.86	22.0	6.7							
65.7	558	2.5	21.75	22.0	6.5							
76.6	479	2.9	18.67	21.8	6.2							
84.7	433	3.2	16.88	21.1	6.0							
104.3	352	3.7	13.72	19.9	5.7							
114.4	321	3.1	12.50	19.3	5.5							
134.5	273	3.5	10.63	18.4	5.3							
165.5	222	4.1	8.64	17.3	4.9							



P_1 [kW]	n_2 [Min ⁻¹]	M_2 [Nm]	f_B	i_{ges}	Fr2 D [kN]	Fr2 C-L [kN]	Typ / Type / Tipo / Type / Tipo	 Kg ~	 mm
4.00	25.5	1455	1.1	37.70	22.0	8.4	D 502 - 132M/6A M 502 - 132M/6A	96	84
	27.9	1326	1.1	34.36	22.0	8.2			
	30.1	1230	1.3	31.86	22.0	8.1			
	32.7	1133	1.4	29.36	22.0	7.9			
	37.1	999	1.6	25.89	22.0	7.7			
	40.2	921	1.7	23.86	22.0	7.5			
	44.1	840	1.8	21.75	22.0	7.3			
	51.4	720	2.0	18.67	22.0	7.0			
	56.9	651	2.3	16.88	22.0	6.8			
	70.0	529	2.6	13.72	22.0	6.5			
	76.8	482	2.2	12.50	22.0	6.3			
	90.3	410	2.4	10.63	21.0	6.0			
	111.1	334	2.8	8.64	19.8	5.7			
	121.9	304	2.9	7.88	19.2	5.5			
	35.4	983	1.2	81.69	22.0	7.7			
38.8	896	1.4	74.45	22.0	7.5				
43.2	822	2.8	66.88	30.0	10.4	D/M 602 - 112M/2A D/M 602 - 100L/2C	108	86	
53.1	670	3.0	54.47	30.0	9.8				
58.2	611	3.0	49.69	30.0	9.6				
21.4	1715	1.7	66.88	30.0	11.2	D 602 - 112M/4B M 602 - 112M/4B	110	86	
26.3	1397	1.9	54.47	30.0	11.2				
28.8	1274	1.9	49.69	30.0	11.2				
32.4	1133	2.6	44.19	30.0	11.2				
34.3	1068	2.8	41.65	30.0	11.0				
40.0	916	3.3	35.72	30.0	10.5				
42.2	870	3.4	33.92	30.0	10.4				
46.2	794	3.8	30.95	30.0	10.2				
14.4	2581	1.2	66.88	30.0	11.2	D 602 - 132M/6A M 602 - 132M/6A	131	86	
17.6	2102	1.3	54.47	30.0	11.2				
19.3	1918	1.3	49.69	30.0	11.2				
21.7	1706	1.8	44.19	30.0	11.2				
23.0	1608	2.0	41.65	30.0	11.2				
26.9	1379	2.3	35.72	30.0	11.2				
28.3	1309	2.4	33.92	30.0	11.2				
31.0	1195	2.6	30.95	30.0	11.2				
33.1	1121	2.8	29.04	30.0	11.2				
36.2	1024	3.1	26.54	30.0	10.9				
40.6	913	3.3	23.65	30.0	10.6				
44.5	833	3.5	21.58	30.0	10.4				
16.3	2132	1.1	177.25	30.0	11.2	D 603 - 100L/2C M 603 - 100L/2C	108	86	
19.1	1816	1.3	150.99	30.0	11.2				
21.7	1605	1.4	133.43	30.0	11.2				
23.5	1479	1.5	122.97	30.0	11.2	D/M 603 - 112M/2A D/M 603 - 100L/2C	108	86	
25.8	1349	1.7	112.19	30.0	11.2				
33.3	1044	2.2	86.78	30.0	11.2				
40.9	850	2.4	70.67	30.0	10.6				
11.6	3088	1.0	122.97	30.0	11.2	D 603 - 112M/4B M 603 - 112M/4B	110	86	
12.7	2817	1.1	112.19	30.0	11.2				
16.5	2179	1.4	86.78	30.0	11.2				
20.2	1775	1.5	70.67	30.0	11.2				
13.6	2672	1.1	70.67	30.0	11.2	D 603 - 132M/6A M 603 - 132M/6A	131	86	



P_1 [kW]	n_2 [Min ⁻¹]	M_2 [Nm]	f_B	i_{ges}	$F_{R2} (M)$ [kN]	$F_{R2} (D,KS)$ [kN]	Typ / Type / Tipo / Type / Tipo	 Kg	 mm
4.80	106.1	415	1.0	13.62	6.0	2.4	D 352 - 112M/4 M 352 - 112M/4	56	80
	120.5	365	1.1	11.99	6.0	2.4			
	147.9	298	1.2	9.77	5.9	2.3			
	176.4	249	1.3	8.19	5.7	2.3			
	42.1	1047	1.0	34.36	18.0	5.6	D 402 - 112M/4 M 402 - 112M/4	65	82
	46.2	953	1.0	31.28	18.0	5.5			
	51.2	859	1.0	28.22	18.0	5.4			
	53.9	817	1.1	26.83	18.0	5.3			
	61.2	719	1.1	23.60	18.0	5.1			
	66.4	662	1.2	21.75	17.6	5.0			
73.0	603	1.3	19.80	17.2	4.9				
85.0	517	1.5	16.99	16.6	4.7				
93.7	470	1.6	15.42	16.2	4.6				
115.6	381	2.0	12.50	15.3	4.4				
127.0	347	2.0	11.38	14.9	4.3				
148.8	296	2.2	9.71	14.3	4.1				
183.5	240	2.5	7.88	13.4	3.8				
201.6	218	2.5	7.17	13.1	3.7				
31.1	1413	1.1	46.39	22.0	7.8	D 502 - 112M/4 M 502 - 112M/4	76	84	
33.3	1320	1.0	43.33	22.0	7.7				
38.3	1148	1.3	37.70	22.0	7.4				
42.1	1047	1.3	34.36	22.0	7.2				
45.4	970	1.5	31.86	22.0	7.1				
49.2	894	1.7	29.36	22.0	6.9				
55.8	789	1.9	25.89	22.0	6.7				
60.5	727	2.1	23.86	22.0	6.6				
66.4	662	2.1	21.75	22.0	6.4				
77.4	568	2.5	18.67	21.5	6.1				
85.6	514	2.7	16.88	20.9	6.0				
105.4	418	3.1	13.72	19.7	5.6				
115.6	381	2.6	12.50	19.2	5.5				
135.9	324	2.9	10.63	18.3	5.2				
167.2	263	3.4	8.64	17.2	4.9				
183.5	240	3.5	7.88	16.7	4.8				
21.6	2037	1.5	66.88	30.0	11.2	D 602 - 112M/4 M 602 - 112M/4	110	86	
26.5	1659	1.6	54.47	30.0	11.2				
29.1	1513	1.6	49.69	30.0	11.2				
32.7	1346	2.2	44.19	30.0	10.9				
34.7	1269	2.4	41.65	30.0	10.8				
40.5	1088	2.8	35.72	30.0	10.4				
42.6	1033	2.9	33.92	30.0	10.2				
46.7	943	3.2	30.95	30.0	10.0				
49.8	884	3.4	29.04	30.0	9.8				
54.4	808	3.7	26.54	30.0	9.6				
61.1	720	4.0	23.65	30.0	9.3				
16.7	2588	1.2	86.78	30.0	11.2	D 603 - 112M/4 M 603 - 112M/4	110	86	
20.4	2107	1.3	70.67	30.0	11.2				

P_1 [kW]	n_2 [Min ⁻¹]	M_2 [Nm]	f_B	i_{ges}	$F_{R2} (M)$ [kN]	$F_{R2} (D,KS)$ [kN]	Typ / Type / Tipo / Type / Tipo	 Kg	 mm			
5.50	145.5	336	1.0	19.93	5.7	2.3	D 352 - 112M/2C M 352 - 112M/2C	67	80			
	178.5	274	1.2	16.25	5.6	2.2						
	212.9	229	1.4	13.62	5.4	2.2						
	241.9	202	1.5	11.99	5.3	2.1						
	296.7	165	1.7	9.77	5.1	2.0						
	354.1	138	1.8	8.19	4.9	2.0						
	68.4	714	1.1	42.38	17.3	4.9				D 402 - 112M/2C M 402 - 112M/2C	76	82
	73.5	664	1.1	39.44	17.0	4.9						
	84.4	579	1.3	34.36	16.4	4.7						
	92.7	527	1.4	31.28	16.0	4.6						
102.8	475	1.4	28.22	15.6	4.5							
108.1	452	1.5	26.83	15.4	4.4							
122.9	398	1.5	23.60	14.9	4.3							
133.3	366	1.7	21.75	14.6	4.2							
146.5	333	1.8	19.80	14.2	4.1							
170.7	286	2.0	16.99	13.6	3.9							
188.1	260	2.3	15.42	13.3	3.8							
232.0	211	2.7	12.50	12.5	3.6							
254.9	192	2.8	11.38	12.1	3.5							
298.6	164	3.0	9.71	11.6	3.3							
368.3	133	3.4	7.88	10.9	3.1							
404.6	121	3.5	7.17	10.6	3.0							
62.3	818	1.0	15.42	17.7	5.0	D 402 - 132M/6B M 402 - 132M/6B	90	82				
76.8	663	1.2	12.50	16.8	4.8							
84.4	604	1.2	11.38	16.5	4.7							
98.8	515	1.3	9.71	15.8	4.5							
121.9	418	1.5	7.88	15.0	4.3							
133.9	380	1.5	7.17	14.6	4.2							
53.9	936	1.0	26.83	18.0	5.2	D 402 - 132S/4C M 402 - 132S/4C	81	82				
61.2	824	1.0	23.60	17.6	5.0							
66.4	759	1.1	21.75	17.3	4.9							
73.0	691	1.1	19.80	16.9	4.8							
85.0	593	1.3	16.99	16.3	4.7							
93.7	538	1.4	15.42	15.9	4.6							
115.6	436	1.7	12.50	15.1	4.3							
127.0	397	1.8	11.38	14.7	4.2							
148.8	339	1.9	9.71	14.1	4.0							
183.5	275	2.2	7.88	13.3	3.8							
201.6	250	2.2	7.17	13.0	3.7							
43.4	1126	1.1	66.83	22.0	7.1	D 502 - 112M/2C M 502 - 112M/2C	87	84				
49.6	985	1.2	58.50	22.0	6.9							
53.4	915	1.1	54.31	22.0	6.7							
62.5	781	1.6	46.39	22.0	6.5							
66.9	730	1.4	43.33	22.0	6.3							
76.9	635	1.8	37.70	21.4	6.1							
84.4	579	1.8	34.36	20.8	6.0							
91.0	537	2.1	31.86	20.4	5.8							
98.8	495	2.3	29.36	19.9	5.7							
112.0	436	2.6	25.89	19.2	5.5							
121.5	402	2.8	23.86	18.8	5.4							
133.3	366	2.9	21.75	18.3	5.2							
155.4	314	3.4	18.67	17.5	5.0							
171.9	284	3.7	16.88	17.0	4.8							
211.4	231	4.3	13.72	15.9	4.6							
232.0	211	3.6	12.50	15.5	4.4							
272.8	179	4.0	10.63	14.8	4.2							
32.7	1558	1.0	29.36	22.0	7.6	D 502 - 132M/6B M 502 - 132M/6B	101	84				
37.1	1374	1.1	25.89	22.0	7.4							
40.2	1267	1.2	23.86	22.0	7.2							
44.1	1154	1.3	21.75	22.0	7.1							
51.4	991	1.5	18.67	22.0	6.8							
56.9	896	1.6	16.88	22.0	6.7							
70.0	728	1.9	13.72	22.0	6.3							
76.8	663	1.6	12.50	21.5	6.1							
90.3	564	1.8	10.63	20.6	5.9							
111.1	459	2.1	8.64	19.4	5.5							
121.9	418	2.1	7.88	18.9	5.4							

P₁ [kW]	n₂ [Min ⁻¹]	M₂ [Nm]	f_B	i_{ges}	F_{R2} (M) [kN]	F_{R2} (D,KS) [kN]	Typ / Type / Tipo / Type / Tipo	Kg ~	
5.50	31.1	1619	1.0	46.39	22.0	7.6	D 502 - 132S/4C M 502 - 132S/4C	92	84
	38.3	1316	1.1	37.70	22.0	7.3			
	42.1	1199	1.2	34.36	22.0	7.1			
	45.4	1112	1.3	31.86	22.0	7.0			
	49.2	1025	1.5	29.36	22.0	6.8			
	55.8	904	1.7	25.89	22.0	6.6			
	60.5	833	1.8	23.86	22.0	6.5			
	66.4	759	1.8	21.75	22.0	6.3			
	77.4	651	2.1	18.67	21.3	6.1			
	85.6	589	2.4	16.88	20.7	5.9			
	105.4	479	2.7	13.72	19.5	5.6			
	115.6	436	2.3	12.50	19.0	5.4			
	135.9	371	2.6	10.63	18.2	5.2			
	167.2	302	3.0	8.64	17.1	4.9			
	183.5	275	3.1	7.88	16.6	4.7			
	43.4	1127	2.0	66.88	30.0	10.1	D 602 - 112M/2C M 602 - 112M/2C	122	86
	53.2	917	2.2	54.47	30.0	9.6			
	58.4	837	2.2	49.69	30.0	9.3			
	65.6	744	3.1	44.19	30.0	9.0			
	69.6	702	3.2	41.65	30.0	8.9			
	81.2	602	3.8	35.72	29.8	8.5			
	85.5	571	4.0	33.92	29.4	8.4			
	19.3	2637	1.0	49.69	30.0	11.2	D 602 - 132M/6B M 602 - 132M/6B	136	86
	21.7	2345	1.3	44.19	30.0	11.2			
	23.0	2211	1.4	41.65	30.0	11.2			
	26.9	1896	1.7	35.72	30.0	11.2			
	28.3	1800	1.7	33.92	30.0	11.1			
	31.0	1643	1.9	30.95	30.0	10.9			
	33.1	1541	2.0	29.04	30.0	10.7			
	36.2	1408	2.2	26.54	30.0	10.5			
	40.6	1255	2.4	23.65	30.0	10.2			
	44.5	1145	2.6	21.58	30.0	10.0			
	21.6	2334	1.3	66.88	30.0	11.2	D 602 - 132S/4C M 602 - 132S/4C	127	86
	26.5	1901	1.4	54.47	30.0	11.2			
	29.1	1734	1.4	49.69	30.0	11.0			
	32.7	1542	1.9	44.19	30.0	10.7			
34.7	1454	2.1	41.65	30.0	10.5				
40.5	1246	2.4	35.72	30.0	10.2				
42.6	1184	2.5	33.92	30.0	10.1				
46.7	1080	2.8	30.95	30.0	9.8				
49.8	1013	3.0	29.04	30.0	9.7				
54.4	926	3.2	26.54	30.0	9.4				
61.1	825	3.5	23.65	30.0	9.2				
67.0	753	3.7	21.58	30.0	8.9				
23.6	2027	1.1	122.97	30.0	11.2	D 603 - 112M/2C M 603 - 112M/2C	122	86	
25.8	1849	1.2	112.19	30.0	11.2				
33.4	1430	1.6	86.78	30.0	10.8				
41.0	1165	1.8	70.67	30.0	10.3				
16.7	2965	1.0	86.78	30.0	11.2	D 603 - 132S/4C M 603 - 132S/4C	127	86	
20.4	2415	1.1	70.67	30.0	11.2				
7.50	85.3	806	1.0	16.99	15.6	4.4	D 402 - 132M/4B M 402 - 132M/4B	92	82
	94.1	731	1.1	15.42	15.3	4.4			
	116.0	593	1.3	12.50	14.5	4.2			
	127.4	540	1.3	11.38	14.2	4.1			
	149.3	461	1.4	9.71	13.7	3.9			
	184.1	373	1.6	7.88	13.0	3.7			
	202.3	340	1.6	7.17	12.7	3.6			
	45.5	1511	1.0	31.86	22.0	6.7	D 502 - 132M/4B M 502 - 132M/4B	103	84
	49.4	1392	1.1	29.36	22.0	6.6			
	56.0	1228	1.2	25.89	22.0	6.4			
	60.8	1132	1.3	23.86	21.9	6.3			
	66.7	1031	1.4	21.75	21.4	6.1			
	77.7	885	1.6	18.67	20.6	5.9			
	85.9	800	1.7	16.88	20.1	5.7			
	105.7	650	2.0	13.72	19.1	5.4			
	116.0	593	1.7	12.50	18.6	5.3			
	136.4	504	1.9	10.63	17.8	5.1			
	167.8	410	2.2	8.64	16.8	4.8			
184.1	373	2.3	7.88	16.3	4.7				

P_1 [kW]	n_2 [Min ⁻¹]	M_2 [Nm]	f_B	i_{ges}	$F_{R2} (M)$ [kN]	$F_{R2} (D,KS)$ [kN]	Typ / Type / Tipo / Type / Tipo	 Kg	 mm			
7.50	56.9	1221	1.2	16.88	22.0	6.4	D 502 - 160M/6B M 502 - 160M/6B	135	84			
	70.0	993	1.4	13.72	21.3	6.1						
	76.8	905	1.2	12.50	20.8	6.0						
	90.3	769	1.3	10.63	20.0	5.7						
	111.1	625	1.5	8.64	18.9	5.4						
	121.9	570	1.6	7.88	18.5	5.3						
	21.7	3171	0.9	66.88	30.0	10.7				D 602 - 132M/4B M 602 - 132M/4B	138	86
	26.6	2583	1.0	54.47	30.0	10.4						
	29.2	2356	1.0	49.69	30.0	10.3						
	32.8	2096	1.4	44.19	30.0	10.1						
	34.8	1975	1.5	41.65	30.0	10.0						
	40.6	1694	1.8	35.72	30.0	9.7						
	42.7	1609	1.9	33.92	30.0	9.6						
	46.9	1468	2.0	30.95	30.0	9.4						
	49.9	1377	2.2	29.04	30.0	9.3						
	54.6	1258	2.4	26.54	30.0	9.1						
	61.3	1121	2.6	23.65	30.0	8.8						
	67.2	1023	2.7	21.58	30.0	8.6						
	23.0	3014	1.0	41.65	30.0	10.6	D 602 - 160M/6B M 602 - 160M/6B	172	86			
	26.9	2585	1.2	35.72	30.0	10.4						
	28.3	2455	1.3	33.92	30.0	10.3						
	31.0	2240	1.4	30.95	30.0	10.2						
	33.1	2102	1.5	29.04	30.0	10.1						
	36.2	1921	1.6	26.54	30.0	9.9						
	40.6	1712	1.8	23.65	30.0	9.7						
	44.5	1562	1.9	21.58	30.0	9.5						
	55.5	1252	2.2	17.30	30.0	9.1						
	68.2	1019	2.5	14.09	30.0	8.7						
	74.7	930	2.5	12.85	29.6	8.5						
	82.4	843	2.4	11.65	28.9	8.3						
101.1	687	2.6	9.49	27.4	7.8							
110.9	627	2.5	8.66	26.8	7.6							
9.20	116.0	727	1.0	12.50	14.1	4.0	D 402 - 132M/4 M 402 - 132M/4	92	82			
	127.4	662	1.1	11.38	13.8	3.9						
	149.3	565	1.2	9.71	13.3	3.8						
	184.1	458	1.3	7.88	12.7	3.6						
	202.3	417	1.3	7.17	12.4	3.5						
	56.0	1506	1.0	25.89	21.6	6.2				D 502 - 132M/4 M 502 - 132M/4	103	84
	60.8	1388	1.1	23.86	21.2	6.1						
	66.7	1265	1.1	21.75	20.8	5.9						
	77.7	1086	1.3	18.67	20.1	5.7						
	85.9	982	1.4	16.88	19.6	5.6						
	105.7	798	1.6	13.72	18.6	5.3						
	116.0	727	1.4	12.50	18.2	5.2						
	136.4	618	1.5	10.63	17.5	5.0						
	167.8	503	1.8	8.64	16.5	4.7						
	184.1	458	1.9	7.88	16.1	4.6						
	32.8	2571	1.2	44.19	30.0	9.5	D 602 - 132M/4 M 602 - 132M/4	138	86			
	34.8	2423	1.2	41.65	30.0	9.5						
	40.6	2078	1.4	35.72	30.0	9.3						
42.7	1973	1.5	33.92	30.0	9.2							
46.9	1800	1.7	30.95	30.0	9.0							
49.9	1689	1.8	29.04	30.0	8.9							
54.6	1544	1.9	26.54	30.0	8.8							
61.3	1376	2.1	23.65	30.0	8.6							
67.2	1255	2.2	21.58	29.4	8.4							
11.00	149.3	676	1.0	9.71	12.9	3.7	D/M 402 - 160M/4B D/M 402 - 132M/4C	124	82			
	184.1	548	1.1	7.88	12.4	3.5						
	202.3	499	1.1	7.17	12.1	3.5						
	77.7	1298	1.1	18.67	19.5	5.6	D/M 502 - 160M/4B D/M 502 - 132M/4C	135	84			

P ₁ [kW]	n ₂ [Min ⁻¹]	M ₂ [Nm]	f _B	i _{ges}	F _{R2} (M) [kN]	F _{R2} (D,KS) [kN]	Typ / Type / Tipo / Type / Tipo	 Kg	 mm
11.00	85.9	1174	1.2	16.88	19.1	5.5	D/M 502 - 160M/4B D/M 502 - 132M/4C	135	84
	105.7	954	1.4	13.72	18.2	5.2			
	116.0	869	1.2	12.50	17.8	5.1			
	136.4	739	1.3	10.63	17.1	4.9			
	167.8	601	1.5	8.64	16.3	4.6			
	184.1	548	1.6	7.88	15.9	4.5			
	111.1	917	1.0	8.64	18.1	5.2	D 502 - 160L/6B M 502 - 160L/6B	148	84
	121.9	836	1.1	7.88	17.7	5.1			
	32.8	3074	1.0	44.19	30.0	9.0	D 602 - 132M/4C M 602 - 132M/4C	172	86
	34.8	2897	1.0	41.65	30.0	8.9	D/M 602 - 160M/4B D/M 602 - 132M/4C	172	86
	40.6	2484	1.2	35.72	30.0	8.8			
	42.7	2359	1.3	33.92	30.0	8.7			
	46.9	2152	1.4	30.95	30.0	8.6			
	49.9	2020	1.5	29.04	29.9	8.6			
	54.6	1846	1.6	26.54	29.5	8.4			
	61.3	1645	1.8	23.65	28.9	8.3			
	67.2	1501	1.9	21.58	28.4	8.1			
	31.0	3285	1.0	30.95	30.0	9.0	D 602 - 160L/6B M 602 - 160L/6B	185	86
	33.1	3082	1.0	29.04	30.0	9.0			
	36.2	2817	1.1	26.54	30.0	8.9			
	40.6	2510	1.2	23.65	30.0	8.8			
	44.5	2290	1.3	21.58	30.0	8.7			
	55.5	1836	1.5	17.30	29.5	8.4			
	68.2	1495	1.7	14.09	28.4	8.1			
	74.7	1364	1.7	12.85	27.9	8.0			
	82.4	1237	1.6	11.65	27.4	7.8			
	101.1	1007	1.8	9.49	26.1	7.5			
	110.9	919	1.7	8.66	25.6	7.3			
83.8	1203	2.2	17.30	27.1	7.8	D 602 - 160M/4B M 602 - 160M/4B	172	86	
102.9	980	2.4	14.09	25.9	7.4				
112.8	894	2.5	12.85	25.4	7.2				
124.4	811	2.3	11.65	24.8	7.1				
152.8	660	2.6	9.49	23.5	6.7				
167.5	602	2.5	8.66	23.0	6.6				
15.00	167.8	819	1.1	8.64	15.7	4.5	D 502 - 160L/4A M 502 - 160L/4A	144	84
	184.1	747	1.1	7.88	15.3	4.4			
	42.7	3217	0.9	33.92	27.3	7.8	D 602 - 160L/4A M 602 - 160L/4A	181	86
	46.9	2935	1.0	30.95	27.2	7.8			
	49.9	2754	1.1	29.04	27.1	7.7			
	54.6	2517	1.2	26.54	26.9	7.7			
	61.3	2243	1.3	23.65	26.6	7.6			
	67.2	2046	1.4	21.58	26.3	7.5			
	83.8	1640	1.6	17.30	25.5	7.3			
	102.9	1336	1.8	14.09	24.6	7.0			
	112.8	1219	1.8	12.85	24.1	6.9			
	124.4	1105	1.7	11.65	23.6	6.8			
	152.8	900	1.9	9.49	22.6	6.5			
	167.5	821	1.8	8.66	22.1	6.3			
	55.8	2491	1.1	17.30	26.8	7.7	D 602 - 180L/6A M 602 - 180L/6A	185	86
	68.5	2028	1.2	14.09	26.3	7.5			
	75.1	1851	1.2	12.85	26.0	7.4			
	82.8	1678	1.2	11.65	25.6	7.3			
101.7	1367	1.3	9.49	24.7	7.1				
111.4	1247	1.3	8.66	24.3	6.9				
18.50	54.6	3104	1.0	26.54	24.6	7.0	D 602 - 180M/4B M 602 - 180M/4B	217	86
	61.3	2766	1.0	23.65	24.6	7.0			
	67.2	2524	1.1	21.58	24.5	7.0			
	83.8	2023	1.3	17.30	24.0	6.9			
	102.9	1648	1.5	14.09	23.3	6.7			
	112.8	1503	1.5	12.85	23.0	6.6			
	124.4	1363	1.4	11.65	22.6	6.5			
	152.8	1110	1.5	9.49	21.8	6.2			
	167.5	1013	1.5	8.66	21.4	6.1			
	102.2	1677	1.1	9.49	23.4	6.7			
	112.0	1530	1.0	8.66	23.1	6.6			

P_1 [kW]	n_2 [Min ⁻¹]	M_2 [Nm]	f_B	i_{ges}	$F_{R2} (M)$ [kN]	$F_{R2} (D,KS)$ [kN]	Typ / Type / Tipo / Type / Tipo	 Kg ~	 mm
22.00	67.4	2991	0.9	21.58	22.6	6.5	D 602 - 180L/4B M 602 - 180L/4B	225	86
	84.1	2398	1.1	17.30	22.5	6.4			
	103.3	1953	1.2	14.09	22.1	6.3			
	113.2	1782	1.2	12.85	21.9	6.3			
	124.8	1616	1.2	11.65	21.6	6.2			
	153.3	1316	1.3	9.49	21.0	6.0			
	168.0	1200	1.2	8.66	20.6	5.9			
30.00	153.8	1788	1.0	9.49	19.1	5.5	D 602 - 200L/4C M 602 - 200L/4C	283	86
	168.6	1631	0.9	8.66	19.0	5.4			

Maßtabelles

Dimension Tables

Dimensione Tabelle

Tables de Dimension

Tablas de Dimensiones

D/M

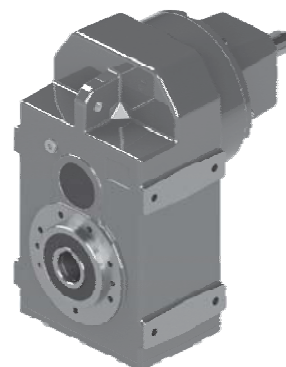
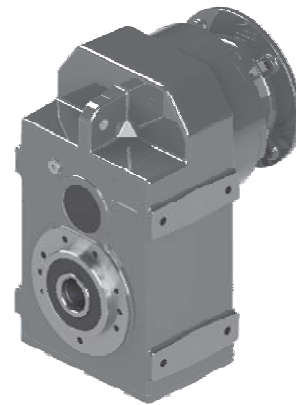
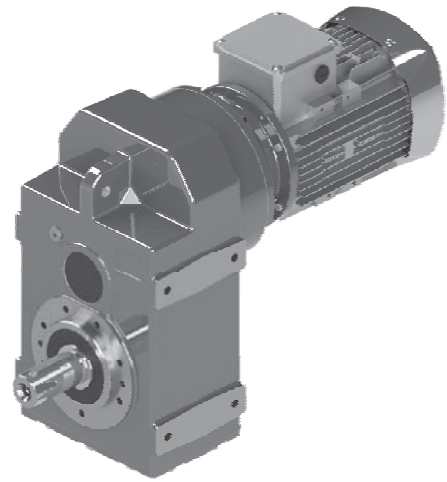

D/M302...602
D/M303...603

D 302-303

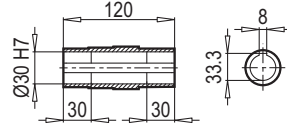
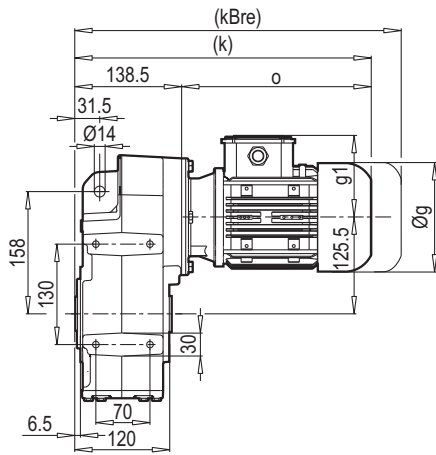

D 302-303 B14

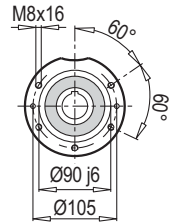
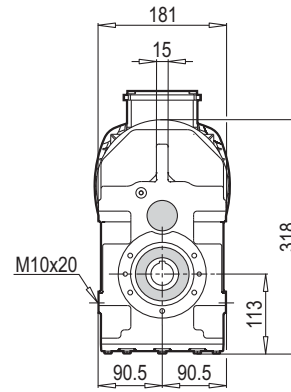

M 302-303

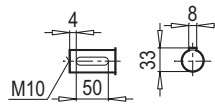
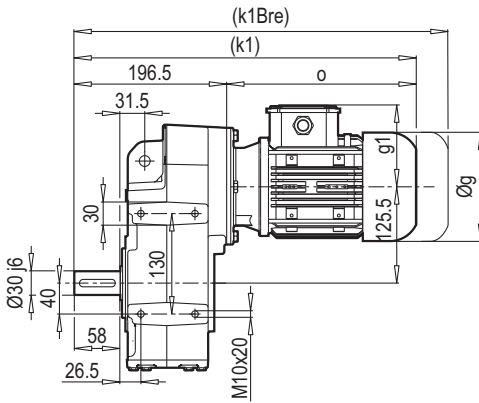

M 302-303 B14

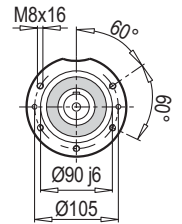
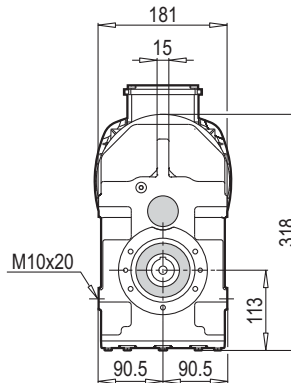

D/M 302-303 B5

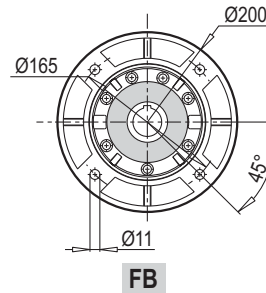
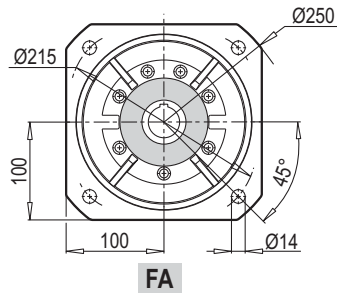
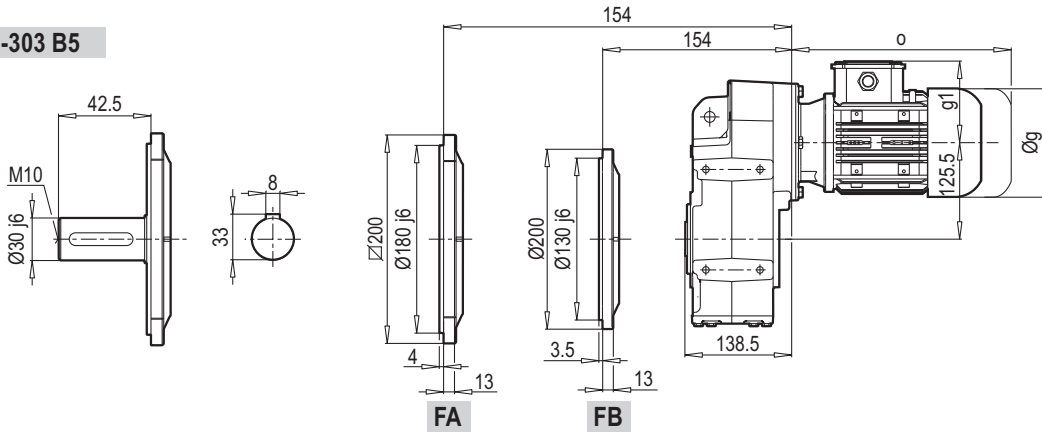

	63M	71M	80M	90S	90L	100L	112M		
g	124	140	159	193	193	217	232		
g1	111	119	127	151	151	160	168		
k/k1	351/409	380/438	406/464	452/510	472/530	473/531	523/581		
kBre/k1Bre	403/461	440/498	468/526	525/583	545/603	554/612	603/661		
o	212	241	267	313	333	334	393		

D 302-303 PAM B5/B14

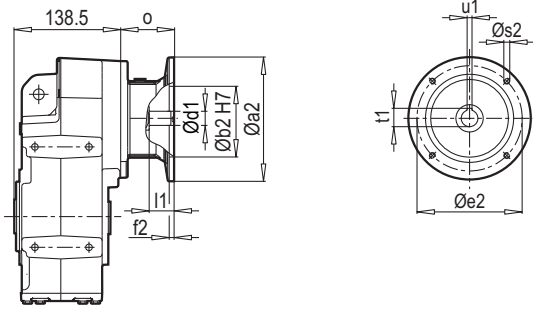

D 302-303 W

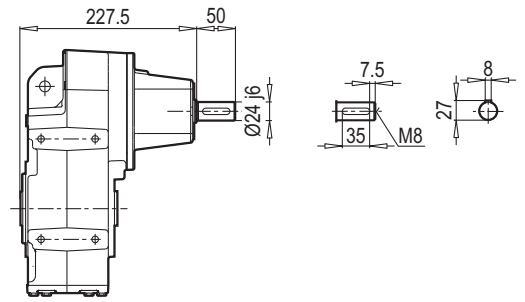

M 302-303 PAM B5/B14

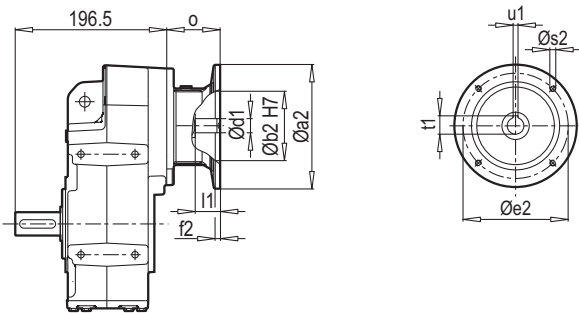

M 302-303 W

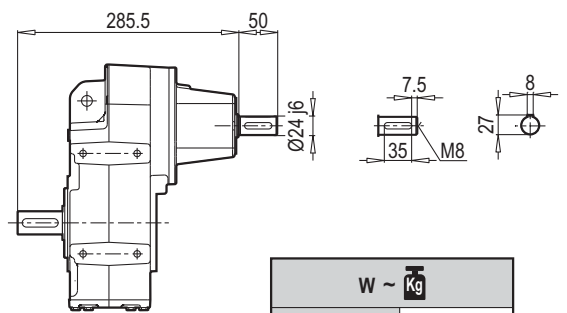

W ~ Kg	
D/M 302 - 303	21

D/M 302-303 B5 PAM B5/B14

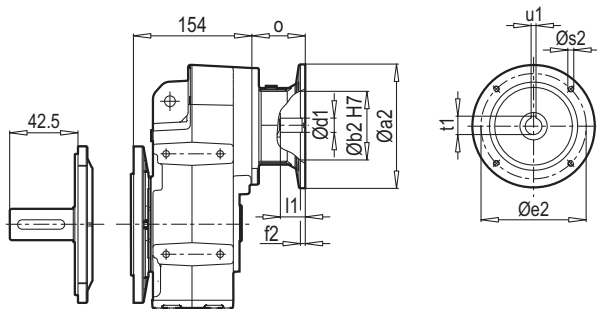

D/M 302-303 B5 W

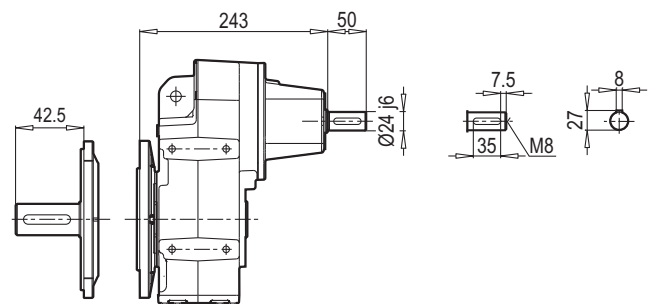

Typ / Type / Tipo Type / Tipo	PAM B5	Øa2	Øb2	Øe2	f2	Øs2	Ød1	l1	t1	u1	o
D/M 302 - 303	63	140	95	115	4.5	8	11	25	12.8	4	57
	71	160	110	130	5	8	14	32	16.3	5	69
	80	200	130	165	5	10	19	42	21.8	6	90
	90	200	130	165	5	10	24	52	27.3	8	90
	100	250	180	215	5.5	12	28	62	31.3	8	105
	112	250	180	215	5.5	12	28	62	31.3	8	105

~ Kg		
PAM B5	D/M 302	D/M303
63	-	19
71	20	20
80	21	21
90	21	21
100	25	-
112	25	-

Typ / Type / Tipo Type / Tipo	PAM B14	Øa2	Øb2	Øe2	f2	Øs2	Ød1	l1	t1	u1	o
D/M 302 - 303	63	90	60	75	2.5	6	11	25	12.8	4	57
	71	105	70	85	2.5	7	14	32	16.3	5	69
	80	120	80	100	3	7	19	42	21.8	6	90
	90	140	95	115	3	9	24	52	27.3	8	90
	100	160	110	130	3.5	9	28	62	31.3	8	105
	112	160	110	130	3.5	9	28	62	31.3	8	105

~ Kg	
PAM B14	D/M 302 - 303
63	18
71	19
80	20
90	20
100	22
112	22

D 352-353

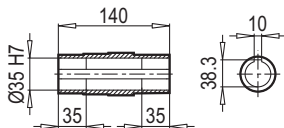
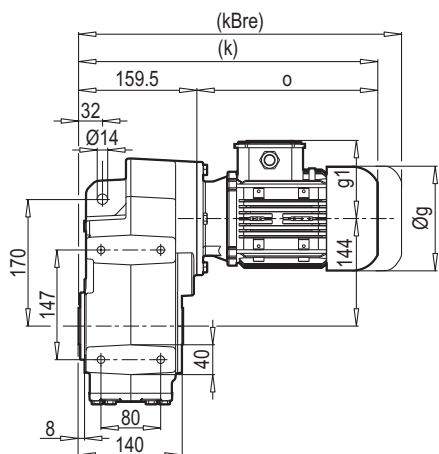

D 352-353 B14

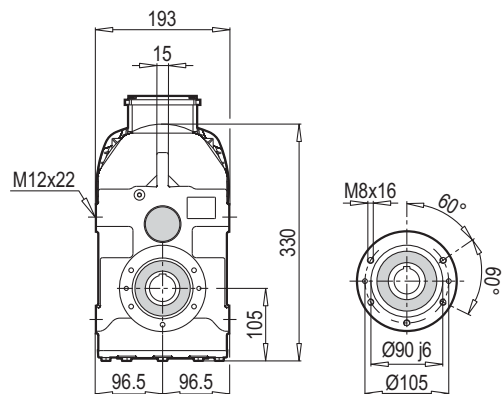

M 352-353

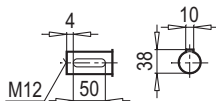
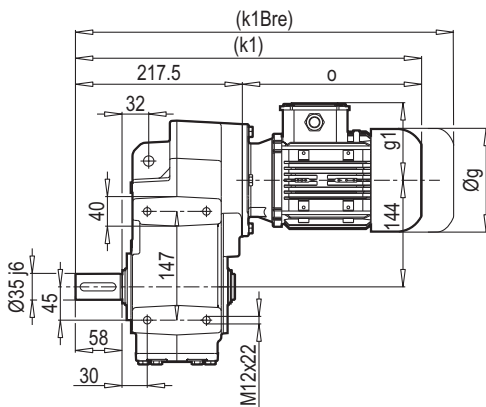

M 352-353...B14

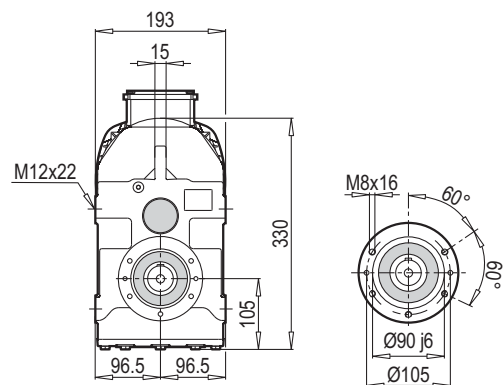

D/M 352-353...B5

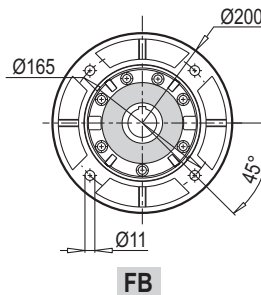
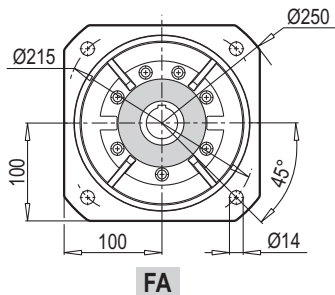
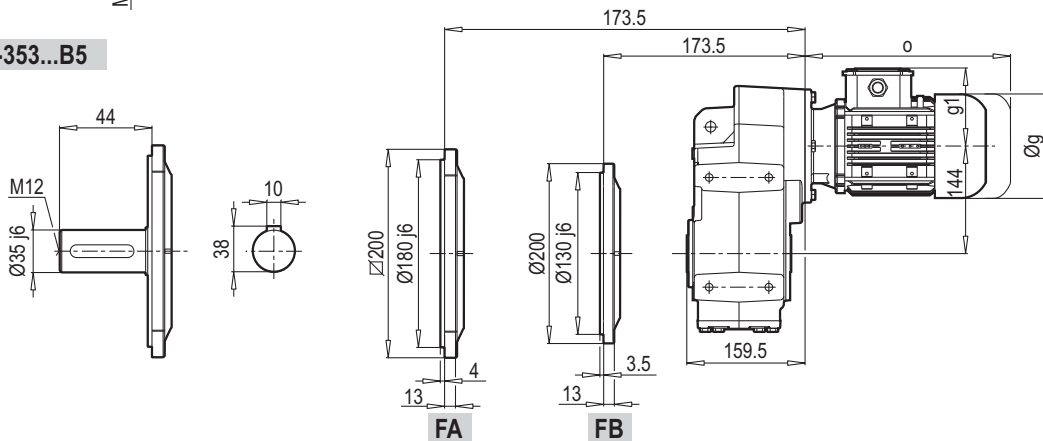

	63M	71M	80M	90S	90L	100L	112M		
g	124	140	159	193	193	217	232		
g1	111	119	127	151	151	160	168		
k/k1	372/430	401/459	427/485	473/531	493/551	494/552	551.5/609.5		
kBre/k1Bre	424/482	461/519	489/547	546/604	566/624	575/633	628/686		
o	212	241	267	313	333	334	393		

D 352-353 PAM B5/B14

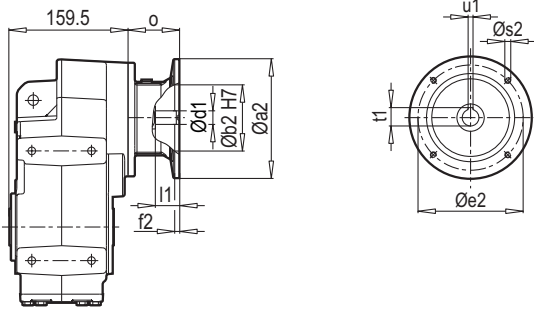

D 352-353 W

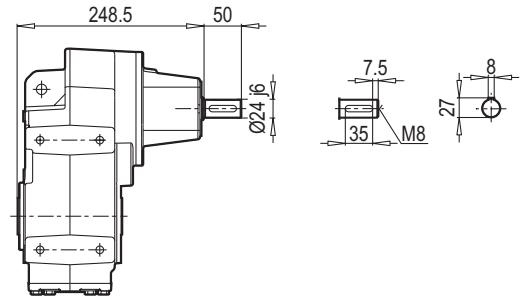

M 352-353 PAM B5/B14

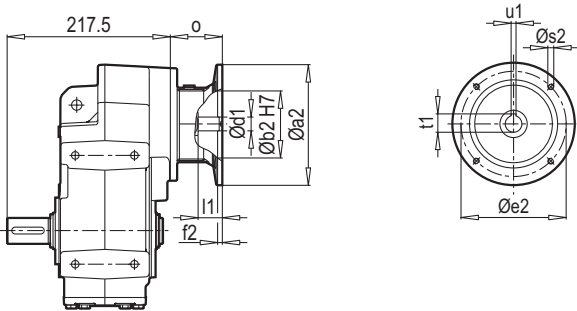

M 352-353 W

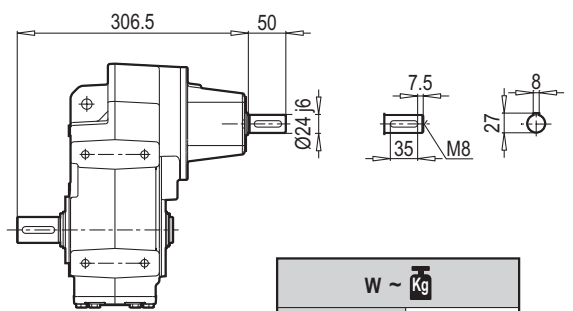

W ~ Kg	
D/M 352 - 353	25

D/M 352-353 B5 PAM B5/B14

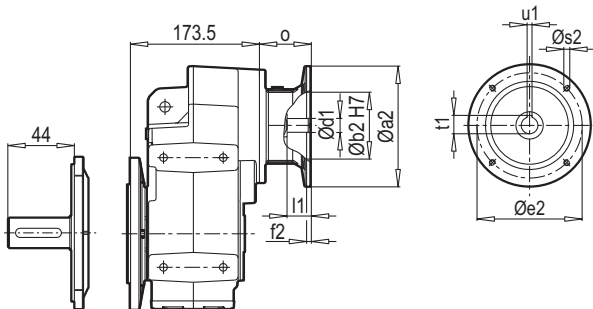

D/M 352-353 B5 W

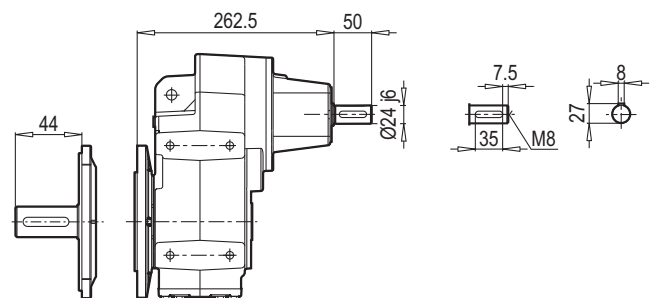

Typ / Type / Tipo Type / Tipo	PAM B5	Øa2	Øb2	Øe2	f2	Øs2	Ød1	l1	t1	u1	o
D/M 352 - 353	63	140	95	115	4.5	8	11	25	12.8	4	57
	71	160	110	130	5	8	14	32	16.3	5	69
	80	200	130	165	5	10	19	42	21.8	6	90
	90	200	130	165	5	10	24	52	27.3	8	90
	100	250	180	215	5.5	12	28	62	31.3	8	105
	112	250	180	215	5.5	12	28	62	31.3	8	105

~ Kg		
PAM B5	D/M 352	D/M 353
63	-	23
71	24	24
80	25	25
90	25	25
100	29	-
112	29	-

Typ / Type / Tipo Type / Tipo	PAM B14	Øa2	Øb2	Øe2	f2	Øs2	Ød1	l1	t1	u1	o
D/M 352 - 353	63	90	60	75	2.5	6	11	25	12.8	4	57
	71	105	70	85	2.5	7	14	32	16.3	5	69
	80	120	80	100	3	7	19	42	21.8	6	90
	90	140	95	115	3	9	24	52	27.3	8	90
	100	160	110	130	3.5	9	28	62	31.3	8	105
	112	160	110	130	3.5	9	28	62	31.3	8	105

~ Kg	
PAM B14	D/M 352 - 353
63	22
71	23
80	24
90	24
100	26
112	26

D 402-403

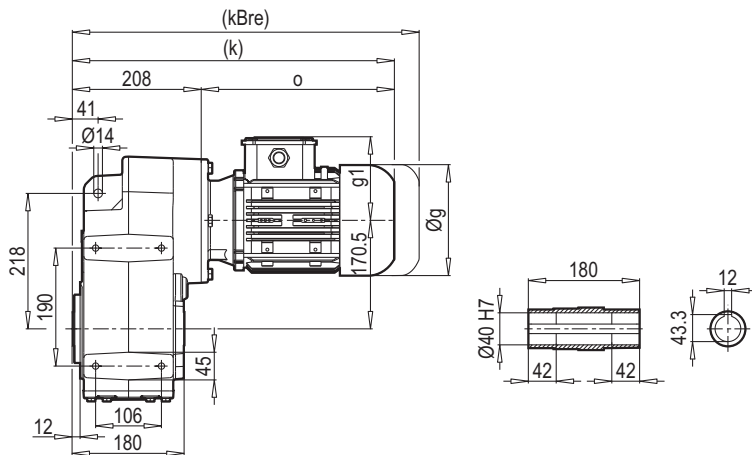

D 402-403...B14

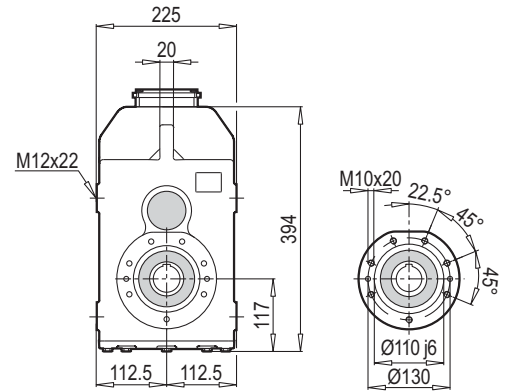

M 402-403

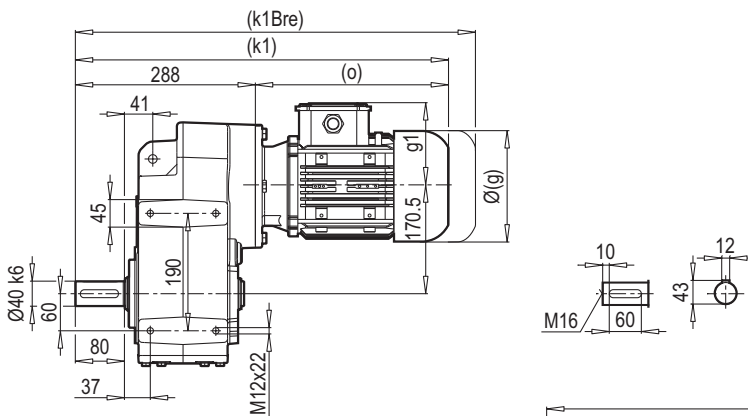

M 402-403...B14

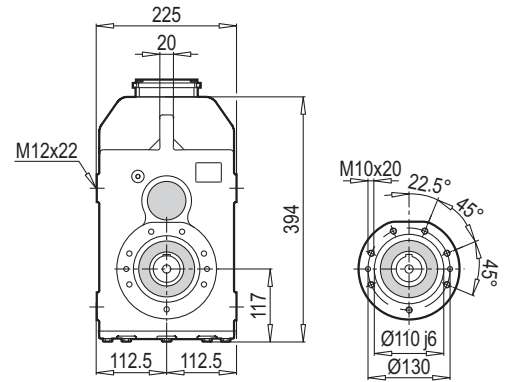

D/M 402-403...B5

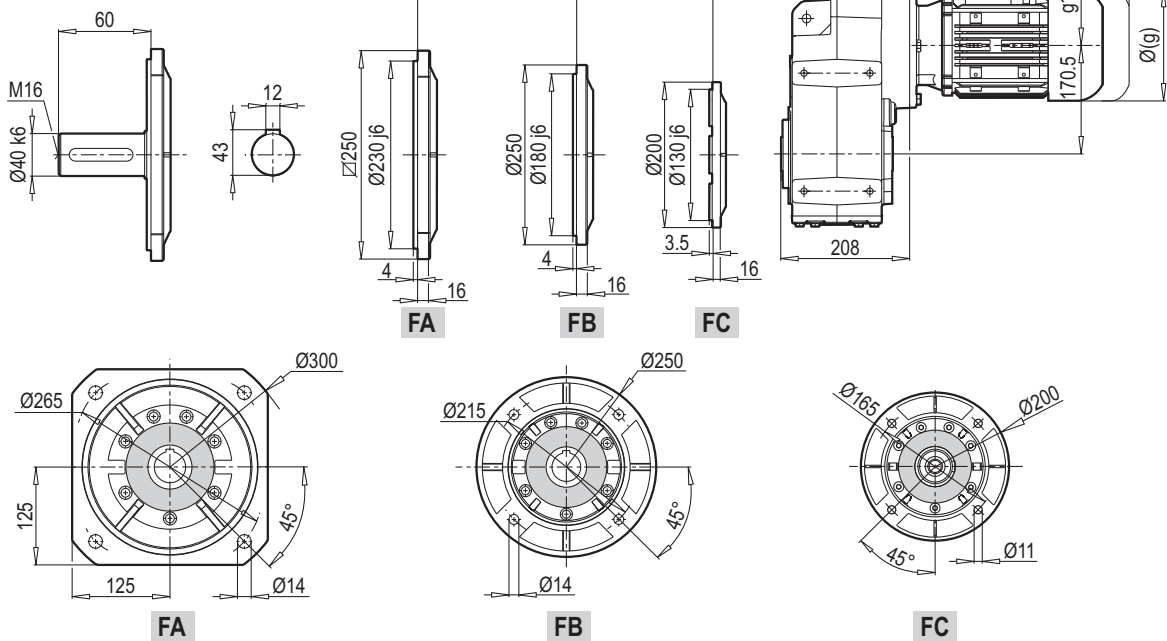

	71M	80M	90S	90L	100L	112M	132S	132M	
g	140	159	193	193	217	232	279	279	
g1	119	127	151	151	160	168	182	182	
k/k1	429/509	455/535	501/581	521/601	544/624	597/677	604/684	639/719	
kBre/k1Bre	489/569	517/597	574/654	594/674	625/705	677/757	712/792	780/860	
o	221	247	293	313	336	389	396	431	

D 402-403 PAM B5/B14

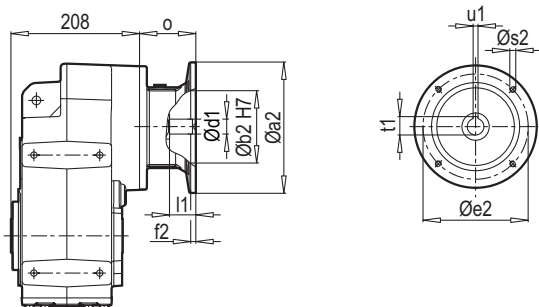

D 402-403 W

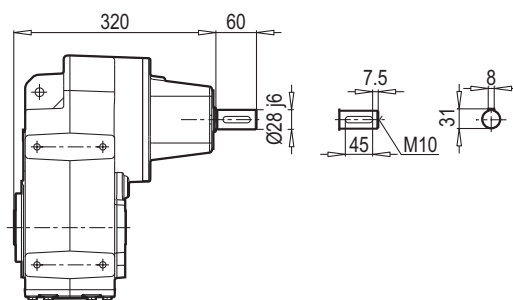

M 402-403 PAM B5/B14

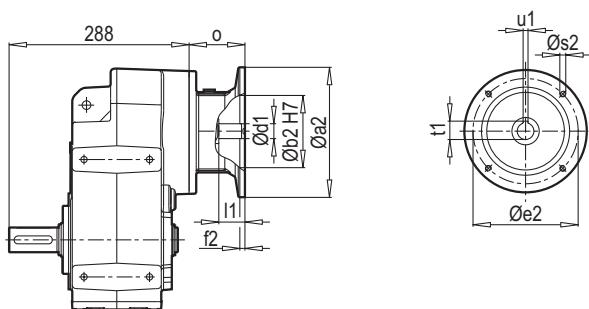

M 402-403 W

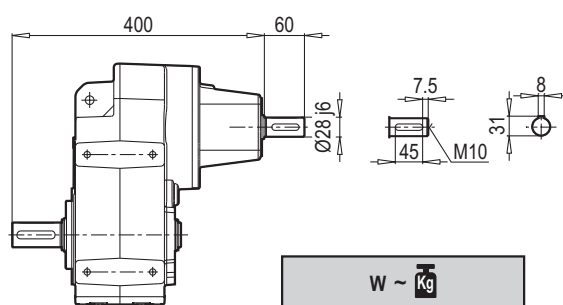

W ~ Kg	
D/M 402 - 403	39

D/M 402-403 B5 PAM B5/B14

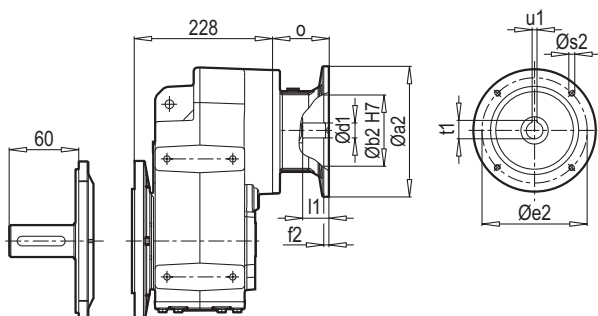

D/M 402-403 B5 W

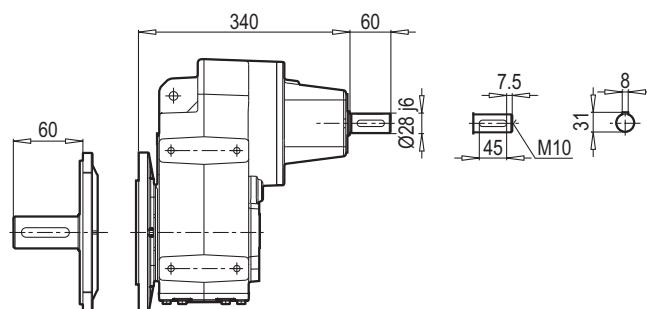

Typ / Type / Tipo Type / Tipo	PAM B5	Øa2	Øb2	Øe2	f2	Øs2	Ød1	l1	t1	u1	o	~ Kg	
												D/M 402	D/M 403
D/M 402 - 403	71	160	110	130	5	8	14	32	16.3	5	49	-	34
	80	200	130	165	5	10	19	42	21.8	6	70	37	37
	90	200	130	165	5	10	24	52	27.3	8	70	37	37
	100	250	180	215	5.5	12	28	62	31.3	8	85	39	39
	112	250	180	215	5.5	12	28	62	31.3	8	85	39	39
	132	300	230	265	5.5	12	38	82	41.3	10	110	43	-

PAM B5	~ Kg	
	D/M 402	D/M 403
71	-	34
80	37	37
90	37	37
100	39	39
112	39	39
132	43	-

Typ / Type / Tipo Type / Tipo	PAM B14	Øa2	Øb2	Øe2	f2	Øs2	Ød1	l1	t1	u1	o	~ Kg	
												D/M 402	D/M 403
D/M 402 - 403	71	105	70	85	2.5	7	14	32	16.3	5	49	32	
	80	120	80	100	3	7	19	42	21.8	6	70	33	
	90	140	95	115	3	9	24	52	27.3	8	70	33	
	100	160	110	130	3.5	9	28	62	31.3	8	85	35	
	112	160	110	130	3.5	9	28	62	31.3	8	85	35	
	132	200	130	165	3.5	11	38	82	41.3	10	110	41	

PAM B14	~ Kg	
	D/M 402	D/M 403
71	32	
80	33	
90	33	
100	35	
112	35	
132	41	

D 502-503

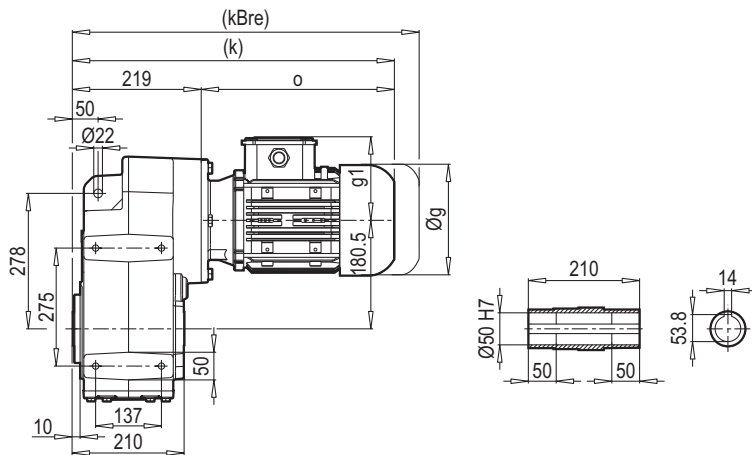

D 502-503...B14

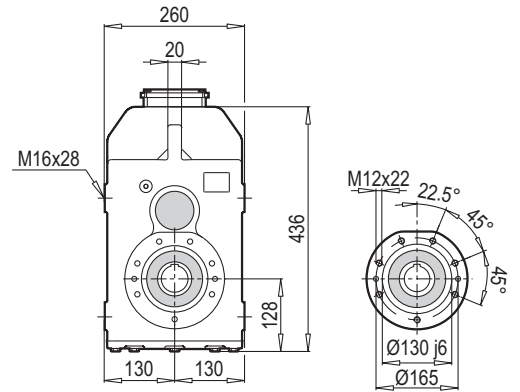

M 502-503

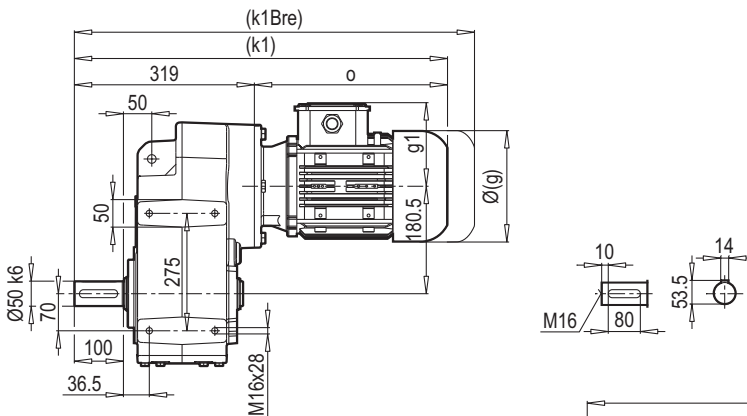

M 502-503...B14

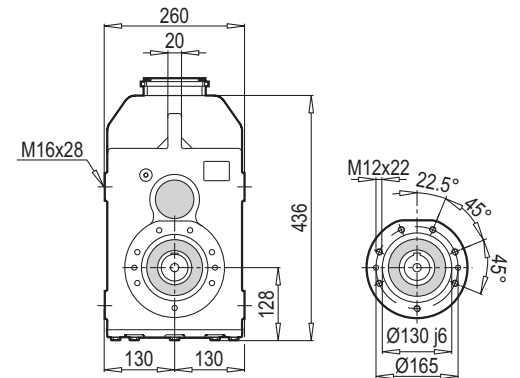

D/M 502-503...B5

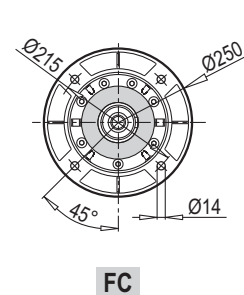
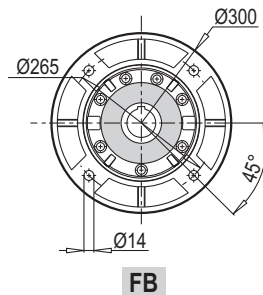
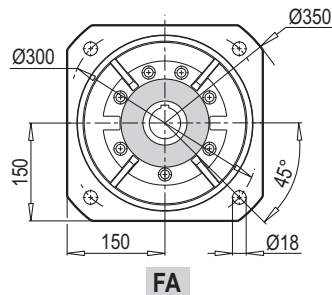
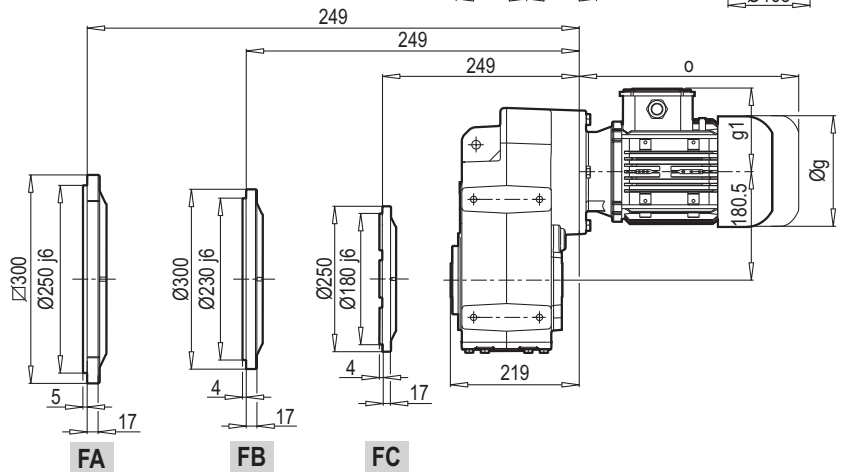
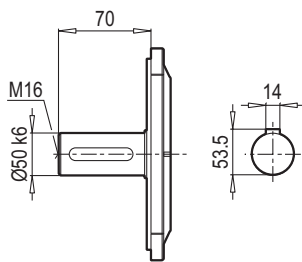

	71M	80M	90S	90L	100L	112M	132S	132M	160M/L
g	140	159	193	193	217	232	279	279	323
g1	119	127	151	151	160	168	182	182	200
k/k1	440/540	466/566	512/612	532/632	555/655	608/708	615/715	650/750	737/837
kBre/k1Bre	500/600	528/628	585/685	605/705	636/736	688/788	723/823	791/890	889/989
o	221	247	293	313	336	389	396	431	518

D 502-503 PAM B5/B14

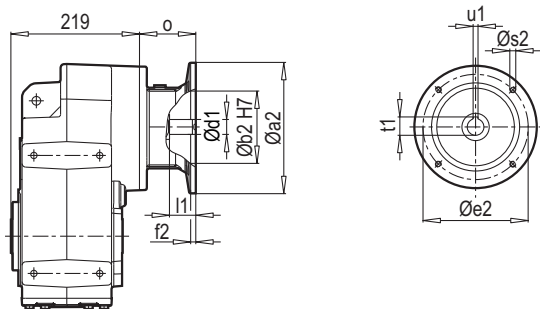

D 502-503 W

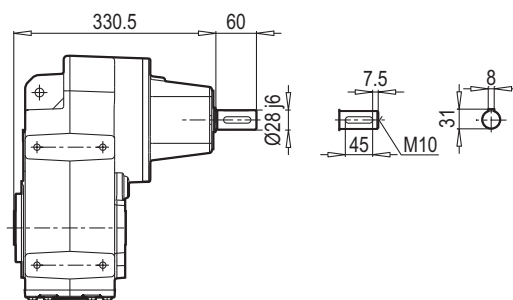

M 502-503 PAM B5/B14

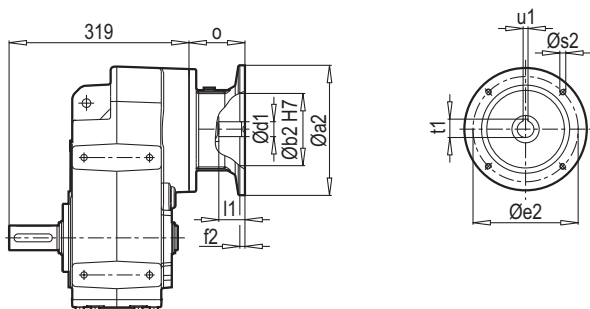

M 502-503 W

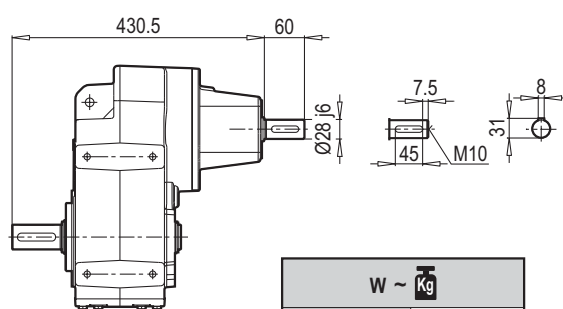

W ~ Kg	
D/M 502 - 503	50

D/M 502-503 B5 PAM B5/B14

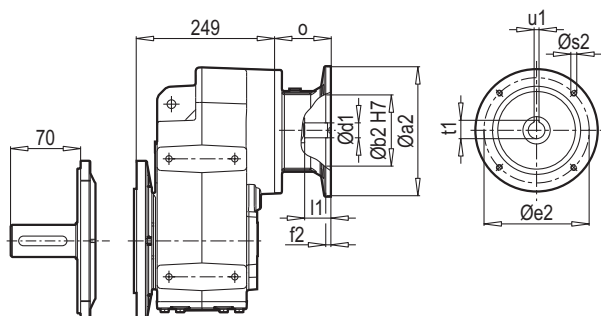

D/M 502-503 B5 W

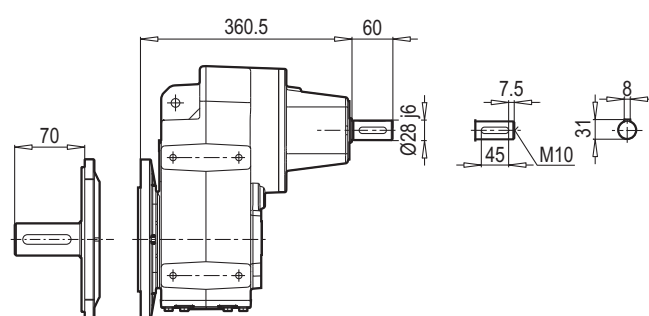

Typ / Type / Tipo Type / Tipo	PAM B5	Øa2	Øb2	Øe2	f2	Øs2	Ød1	l1	t1	u1	o
D/M 502 - 503	71	160	110	130	5	8	14	32	16.3	5	49
	80	200	130	165	5	10	19	42	21.8	6	70
	90	200	130	165	5	10	24	52	27.3	8	70
	100	250	180	215	5.5	12	28	62	31.3	8	85
	112	250	180	215	5.5	12	28	62	31.3	8	85
	132	300	230	265	5.5	12	38	82	41.3	10	110
	160	350	250	300	7	16	42	112	45.3	12	158

~ Kg		
PAM B5	D/M 502	D/M 503
71	-	45
80	48	48
90	48	48
100	50	50
112	50	50
132	54	-
160	61	-

Typ / Type / Tipo Type / Tipo	PAM B14	Øa2	Øb2	Øe2	f2	Øs2	Ød1	l1	t1	u1	o
D/M 502 - 503	71	105	70	85	2.5	7	14	32	16.3	5	49
	80	120	80	100	3	7	19	42	21.8	6	70
	90	140	95	115	3	9	24	52	27.3	8	70
	100	160	110	130	3.5	9	28	62	31.3	8	85
	112	160	110	130	3.5	9	28	62	31.3	8	85
	132	200	130	165	3.5	11	38	82	41.3	10	110

~ Kg	
PAM B14	D/M 502 - 503
71	43
80	44
90	44
100	46
112	46
132	51

D 602-603

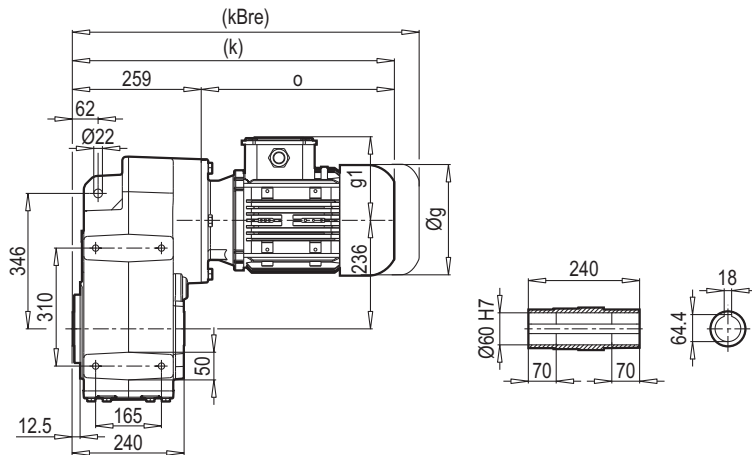

D 602-603...B14

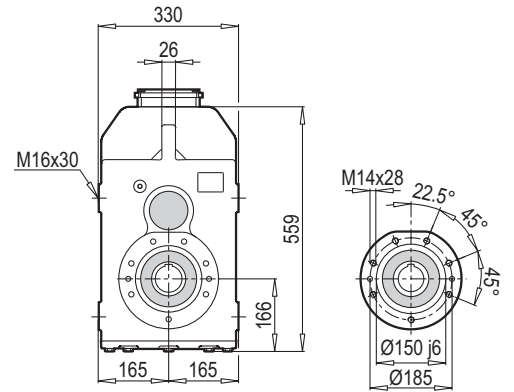

M 602-603

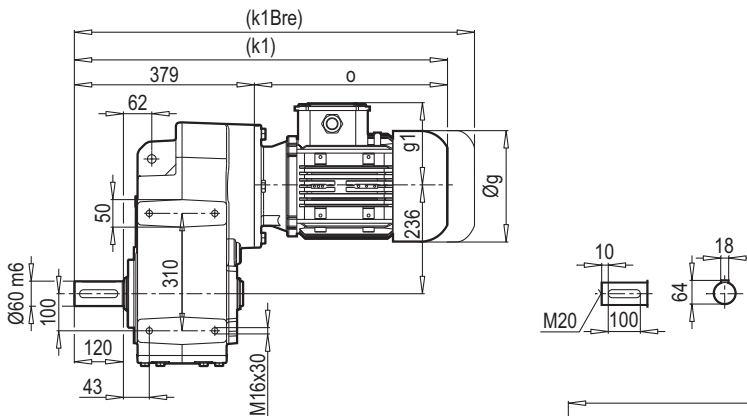

M 602-603...B14

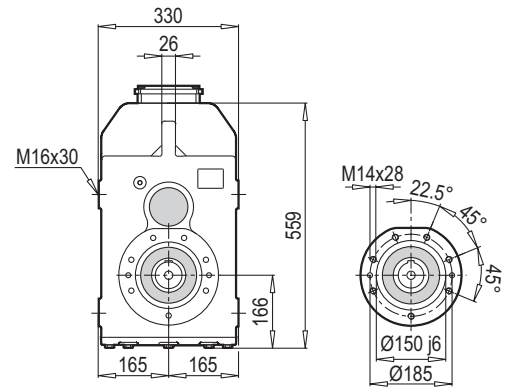

D/M 602-603...B5

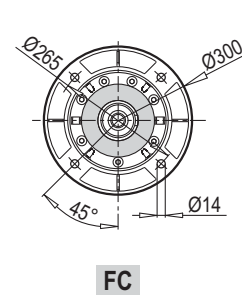
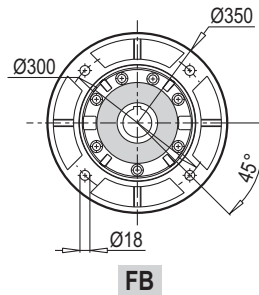
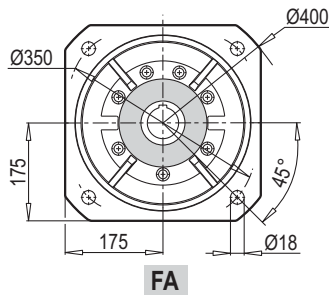
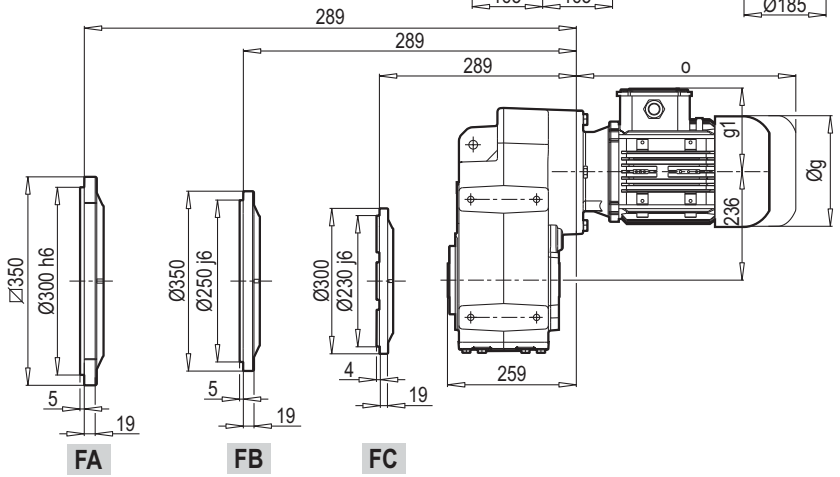
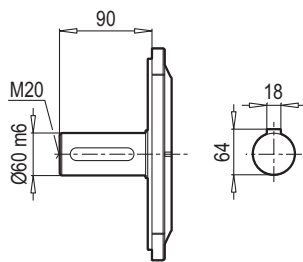

	80M	90S	90L	100L	112M	132S	132M	160M/L	180M/L	200L
g	159	193	193	217	232	279	279	323	370	415
g1	127	151	151	160	168	182	182	200	248	260
k/k1	517/637	542/662	562/682	585/705	639/759	645/765	680/800	767/887	832/952	869/989
kBre/k1Bre	579/699	615/735	635/755	666/786	719/839	753/873	821/941	919/1039	994/1114	1016/1136
o	258	283	303	326	380	386	421	508	573	610

D 602-603 PAM B5/B14

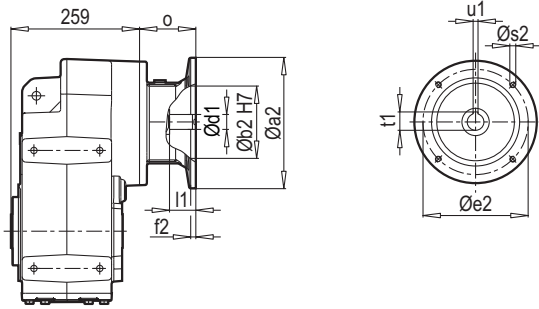

D 602-603 W

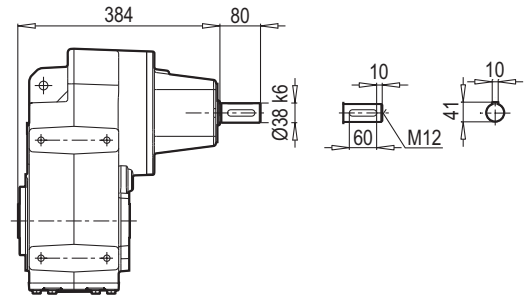

M 602-603 PAM B5/B14

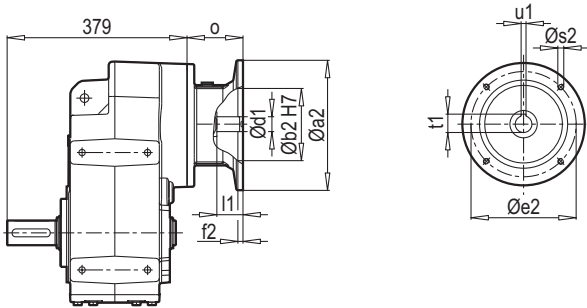

M 602-603 W

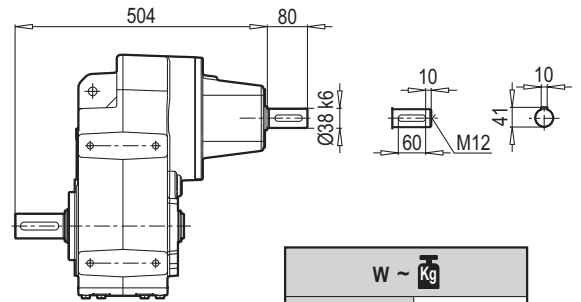

W ~ Kg	
D/M 602 - 603	92

D/M 602-603 B5 PAM B5/B14

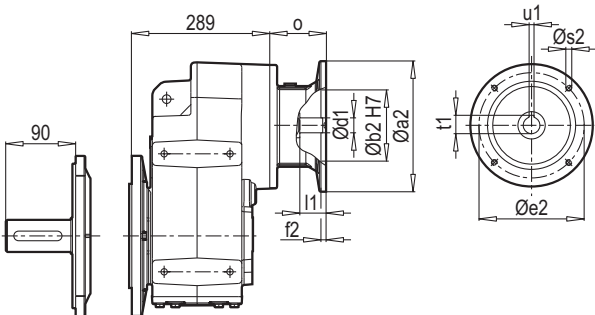

D/M 602-603 B5 W

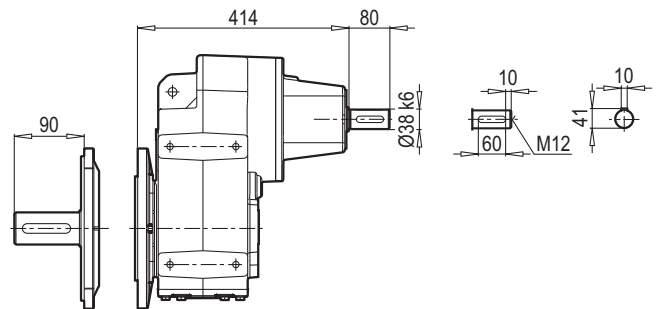

Typ / Type / Tipo Type / Tipo	PAM B5	Øa2	Øb2	Øe2	f2	Øs2	Ød1	l1	t1	u1	o
D/M 602 - 603	80	200	130	165	5	10	19	42	21.8	6	61
	90	200	130	165	5	10	24	52	27.3	8	61
	100	250	180	215	5.5	12	28	62	31.3	8	76
	112	250	180	215	5.5	12	28	62	31.3	8	76
	132	300	230	265	5.5	12	38	82	41.3	10	101
	160	350	250	300	7	16	42	112	45.3	12	148
	180	350	250	300	7	16	48	112	51.8	14	148
	200	400	300	350	7	16	55	112	59.3	16	185

~ Kg		
PAM B5	D/M 602	D/M 603
80	83	83
90	83	83
100	87	87
112	87	87
132	90	90
160	96	-
180	96	-
200	112	-

Typ / Type / Tipo Type / Tipo	PAM B14	Øa2	Øb2	Øe2	f2	Øs2	Ød1	l1	t1	u1	o
D/M 602 - 603	80	120	80	100	3	7	19	42	21.8	6	61
	90	140	95	115	3	9	24	52	27.3	8	61
	100	160	110	130	3.5	9	28	62	31.3	8	76
	112	160	110	130	3.5	9	28	62	31.3	8	76
	132	200	130	165	3.5	11	38	82	41.3	10	101

~ Kg	
PAM B14	D/M 602 - 603
80	80
90	80
100	82
112	82
132	88



A series of horizontal dotted lines spanning the width of the page, intended for writing or drawing.